

Triple-Output Programmable DC Power Supply

NI PXI-4110 **NEW!**

- 3 independent DC power supplies
 - 0 to 6 VDC, 1 A, nonisolated
 - 0 to +20 VDC, 1 A, isolated
 - 0 to -20 VDC, 1 A, isolated
- 16-bit voltage setpoint and current limit
- 16-bit voltage/current readback measurements
- 20 mA and 1 A current modes
- 2 power source options
 - Internal (PXI backplane) – 9 W output
 - Auxiliary – full 46 W output
- Isolated channels can be combined for 0 to +40 VDC operation

Operating Systems

- Windows Vista/XP/2000

Recommended Software

- LabVIEW
- LabVIEW Real-Time Module
- LabWindows™/CVI
- Measurement Studio
- LabVIEW SignalExpress

Other Compatible Software

- Microsoft Visual Basic
- C/C++

Driver Software (included)

- NI-DCPower



Overview

The National Instruments PXI-4110 is a programmable, triple-output precision DC power supply in a single-slot, 3U PXI module. The NI PXI-4110 has two isolated channels, one from 0 to +20 V and the other from 0 to -20 V, and a single nonisolated 0 to 6 V supply, all capable of sourcing up to 1 A per channel. The PXI-4110 has 16-bit resolution for programming the voltage setpoint and current limit and for using the voltage and current readback measurement functionality. The versatile supply rails and high accuracy make the PXI-4110 an excellent general-purpose, single-quadrant power supply for design validation and manufacturing test applications.

Power Supply with Precision Source Capability

The PXI-4110 has the ability to source both voltage and current from each of its three outputs. As a voltage source, it can be programmed in 120 μ V steps on the +6 V channel and 400 μ V steps on each of the 20 V channels. As a current source, it can be programmed in 20 μ A steps on each channel in the 1 A current range. Additionally, you can set each of the 20 V channels to a 20 mA current range for 400 nA programming resolution. You can use this impressive level of current resolution in traditional power supply applications or in many applications that typically require a separate precision source measure unit.

Internal/External Supply Options

You can power the PXI-4110 either internally from the PXI backplane or externally through the NI APS-4100, a front-panel-connected auxiliary DC supply. Using internal power reduces the number of connections required on the front panel but also limits the available output power because of per-slot PXI power restrictions. When internally powered, the nonisolated, 0 to 6 V channel can be operated at its full 1 A current range, but the isolated channels are limited to 100 mA. When externally powered, all channels can be operated at full power of 1 A per channel for a total maximum output power of 46 W.

Linear Supply with Switching Preregulation

The PXI-4110 uses a combination of switching and linear regulation to provide excellent output power and accuracy in the 3U PXI module. On each channel, input power (coming from either the PXI backplane or the APS-4100) is regulated to within a certain percentage of the desired output power. This preregulation stage is governed by an intelligent PID algorithm implemented on board the module, ensuring the amount of power passed to the second (linear) stage is at the most efficient level, given the desired output.

After additional filtering, you can use traditional linear regulation techniques and amplification to further regulate the signal and source the final voltage or current. Because the output is linearly regulated, it has very quick load response and high precision – even at levels as low as 0 V. Also, because the linear regulation occurs on the preregulated signal, the power dissipation is relatively small and easily cooled in a PXI slot.

Triple-Output Programmable DC Power Supply

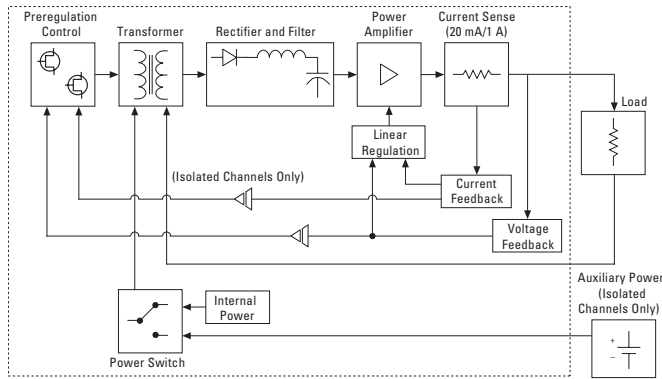

Architecture of Single Isolated Channel on the PXI-4110

Extensive Protection Features

In addition to the standard voltage and current limiting functionality of the PXI-4110, several other features are included to protect the supply and the load. Each output is protected against a reverse-polarity voltage application as well as excessive voltages – up to 15 V above the maximum channel voltage. Output fuses provide additional protection to prevent catastrophic failure as a last line of defense.

The operating voltage range for the auxiliary power input is 11 to 15.5 V. If voltages outside these limits are detected, the module shuts down until an input voltage within range is applied. If an input in excess of 20 V is applied, the input crowbar protection turns on, protecting the input solid-state switching devices (and preregulator power supply) from overvoltage damage.

The PXI-4110 operates with only nominal temperature increases internally due to the intelligent PID control of the output devices. If an overtemperature condition occurs in the PXI chassis due to fan failure or intake blockage, the output channels are shut down and a warning is issued. This type of condition requires user software intervention to reset, thus preventing the module from damage at excessive temperatures.

Software

NI-DCPower, an IVI-compliant instrument driver, offers complete programmatic control of the PXI-4110. You can use an available test panel to quickly troubleshoot or debug power supply operation and take advantage of the DCPower Express VI for an intuitive, configuration-based method of programming in the National Instruments LabVIEW graphical development environment.

Ordering Information

NI PXI-4110.....	779647-10
Includes NI-DCPower and the DCPower Test Panel.	
NI APS-4100	779671-01
NI PXI-4110, NI APS-4110 Bundle	779647-11

BUY NOW!

For complete product specifications, pricing, and accessory information, call 800 813 3693 (U.S.) or go to ni.com/modularinstruments.

Triple-Output Programmable DC Power Supply

Specifications

Specifications subject to change without notice. For the most current and complete specifications, visit ni.com/modularinstruments.

Supply Characteristics

Number of channels..... 3

DC Specifications

Channel	DC Voltage	Isolation ¹	DC Current (Power)			
			Auxiliary Power		Internal Power	
			20 mA Range	1 A Range	20 mA Range	1 A Range
0	0 to +6 V	N/A	N/A	1 A (6 W)	N/A	1 A (6 W)
1	0 to +20 V	60 VDC, CAT I	20 mA	1 A (20 W)	20 mA	100 mA (2 W) ²
2	0 to -20 V	60 VDC, CAT I	20 mA	1 A (20 W)	20 mA	100 mA (2 W) ²

¹Channels 1 and 2 are isolated from ground but not from each other.

²Combined total power for channels 1 and 2 using internal power cannot exceed 3 W.

Voltage Programming Accuracy/Resolution

Channels	Range (V)	Resolution (mV)	Accuracy ±(% of output + offset)	
			1-Year 13 to 33 °C	Tempco/°C 0 to 55 °C
0	+6	0.12	0.05 + 4 mV	0.005 + 0.3 mV
1	+20	0.40	0.05 + 10 mV	0.005 + 1 mV
2	-20	0.40	0.05 + 10 mV	0.005 + 1 mV

Tempco = temperature coefficient

Current Programming Accuracy/Resolution³

Channels	Range ⁴	Resolution	Accuracy ±(% of output + offset)	
			1-Year 13 to 33 °C	Tempco/°C 0 to 55 °C
0	1 A	0.02 mA	0.15 + 4 mA	0.02 + 0.2 mA
1 and 2	20 mA	0.40 µA	0.15 + 60 µA	0.01 + 3 µA
	1 A	0.02 mA	0.15 + 4 mA	0.02 + 0.2 mA

Tempco = temperature coefficient

³Applies for current settings greater than 2% of range.

⁴Minimum programmable current limit is 2% of range.

Voltage Readback Accuracy/Resolution

Channels	Range (V)	Resolution (mV)	Accuracy ±(% of output + offset)	
			1-Year 13 to 33 °C	Tempco/°C 0 to 55 °C
0	+6	0.06	0.05 + 4 mV	0.005 + 0.2 mV
1	+20	0.20	0.05 + 5 mV	0.005 + 0.5 mV
2	-20	0.20	0.05 + 5 mV	0.005 + 0.5 mV

Tempco = temperature coefficient

Current Readback Accuracy/Resolution⁵

Channels	Range	Resolution	Accuracy ±(% of output + offset)	
			1-Year 13 to 33 °C	Tempco/°C 0 to 55 °C
0	1 A	0.01 mA	0.15 + 4 mA	0.02 + 0.2 mA
1 and 2	20 mA	0.20 µA	0.15 + 35 µA	0.01 + 3 µA
	1 A	0.01 mA	0.15 + 4 mA	0.02 + 0.2 mA

Tempco = temperature coefficient

⁵Applies for current outputs up to 500 mA.

Ripple and Noise

Channels	RMS Normal-Mode Voltage ⁶	RMS Normal-Mode Current ⁷ (20 mA into 500 Ω load)
0	<1.5 mV	<8 µA
1 and 2	<1.0 mV	<8 µA (<3 µA for 20 mA range)

⁶From 20 Hz to 20 MHz. ⁷Current noise bandwidth is limited to 10 kHz for 1 A range and 400 Hz for 20 mA range.

Voltage Output Speed⁸

Channels	Auxiliary Power				Internal Power			
	Rise Time ⁹		Fall Time ¹⁰		Rise Time ⁹		Fall Time ¹⁰	
	Full Load	No Load	Full Load	No Load	Full Load	No Load	Full Load	No Load
0	<1 ms	<1 ms	<1 ms	<25 ms	Same as auxiliary power			
1 and 2	<1 ms	<1 ms	<2 ms	<56 ms	<20 ms	<10 ms	<15 ms	<56 ms

⁸Current limit set to 1 A for auxiliary power or 100 mA for internal power. For 20 mA range, all voltage output speeds are <80 ms.

⁹Rise time is from 10 to 90% of programmed voltage change at maximum current.

¹⁰Fall time is from 90 to 10% of programmed voltage change at maximum current.

Line and Load Regulation

Channels	Line Regulation ¹¹ ±(% of output + offset)		Load Regulation ±(% of range selected)	
	Voltage	Current	Voltage (per A of output load)	Current (per V of output load)
0	N/A	N/A	0.42	0.02
1 and 2	0.01 + 1 mV	0.01 + 0.02% of range	0.1	0.007 (0.003 for 20 mA range)

¹¹Per volt change in auxiliary input.

General Specifications

Sampling rate	
Default	300 S/s (10 samples averaged)
Maximum	3000 S/s
Warm-up	15 minutes
I/O connectors	
Supply channels.....	6-pos COMBICON (3.81 mm)
External power.....	2-pos COMBICON (3.5 mm)
Dimensions.....	13.1 by 21.6 cm (5.1 by 8.5 in.)
	Single PXI slot, 3U
Auxiliary power (optional).....	11 to 15.5 VDC, 5 A max

Environment

Operating temperature	0 to 55 °C
Storage temperature.....	-20 to 70 °C
Relative humidity	5 to 85% noncondensing
Pollution degree	2
Approved altitude	up to 2000 m

Safety

This product is designed to meet the requirements of the following standards of safety for electrical equipment for measurement, control, and laboratory use:

- IEC 61010-1, EN 61010-1
- UL 61010-1, CSA 61010-1

For UL and other safety certifications, refer to the product label, or visit ni.com/certification, search by model number or product line, and click the appropriate link in the Certification column.

Electromagnetic Compatibility

- CE, C-Tick, ICES, and FCC Part 15 Emissions; Class A
- EN 55011 Emissions; Group 1, Class A
- EN 61326 EMC requirements; Minimum Immunity

For EMC compliance, operate this device according to product documentation.

Triple-Output Programmable DC Power Supply

CE Compliance

This product meets the essential requirements of applicable European Directives, as amended for CE marking, as follows:

- 2006/95/EC; Low-Voltage Directive (safety)
- 2004/108/EC; Electromagnetic Compatibility Directive (EMC)

Refer to the Declaration of Conformity (DoC) for this product for any additional regulatory compliance information. To obtain the DoC for this product, visit ni.com/certification, search by model number or product line, and click the appropriate link in the Certification column.

Waste Electrical and Electronic Equipment (WEEE)

EU Customers: At the end of their life cycle, all products must be sent to a WEEE recycling center. For more information about WEEE recycling centers and National Instruments WEEE initiatives, visit ni.com/environment/weee.htm.

Environmental Management

NI is committed to designing and manufacturing products in an environmentally responsible manner. NI recognizes that eliminating certain hazardous substances from our products is beneficial not only to the environment but also to NI customers.

For additional environmental information, refer to the NI and the Environment Web page at ni.com/environment. This page contains the environmental regulations and directives with which NI complies, as well as any other environmental information not included in this document.

NI Services and Support



NI has the services and support to meet your needs around the globe and through the application life cycle – from planning and development through deployment and ongoing maintenance. We offer services and service levels to meet customer requirements in research, design, validation, and manufacturing. Visit ni.com/services.

Training and Certification

NI training is the fastest, most certain route to productivity with our products. NI training can shorten your learning curve, save development time, and reduce maintenance costs over the application life cycle. We schedule instructor-led courses in cities worldwide, or we can hold a course at your facility. We also offer a professional certification program that identifies individuals who have high levels of skill and knowledge on using NI products. Visit ni.com/training.

Professional Services

Our NI Professional Services team is composed of NI applications and systems engineers and a worldwide National Instruments Alliance Partner program of more than 600 independent consultants and

integrators. Services range from start-up assistance to turnkey system integration. Visit ni.com/alliance.



OEM Support

We offer design-in consulting and product integration assistance if you want to use our products for OEM applications. For information about special pricing and services for OEM customers, visit ni.com/oem.

Local Sales and Technical Support

In offices worldwide, our staff is local to the country, giving you access to engineers who speak your language. NI delivers industry-leading technical support through online knowledge bases, our applications engineers, and access to 14,000 measurement and automation professionals within NI Developer Exchange forums. Find immediate answers to your questions at ni.com/support.

We also offer service programs that provide automatic upgrades to your application development environment and higher levels of technical support. Visit ni.com/ssp.

Hardware Services

NI Factory Installation Services

NI Factory Installation Services (FIS) is the fastest and easiest way to use your PXI or PXI/SCXI combination systems right out of the box. Trained NI technicians install the software and hardware and configure the system to your specifications. NI extends the standard warranty by one year on hardware components (controllers, chassis, modules) purchased with FIS. To use FIS, simply configure your system online with ni.com/pxiadvisor.

Calibration Services

NI recognizes the need to maintain properly calibrated devices for high-accuracy measurements. We provide manual calibration procedures, services to recalibrate your products, and automated calibration software specifically designed for use by metrology laboratories. Visit ni.com/calibration.

Repair and Extended Warranty

NI provides complete repair services for our products. Express repair and advance replacement services are also available. We offer extended warranties to help you meet project life-cycle requirements. Visit ni.com/services.



ni.com • 800 813 3693

National Instruments • info@ni.com



342576E-01

2007-9223-101-D-E