

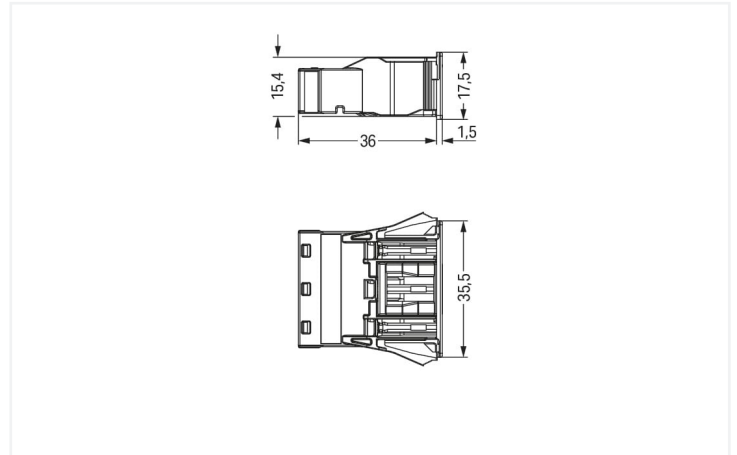

Color: ■ black

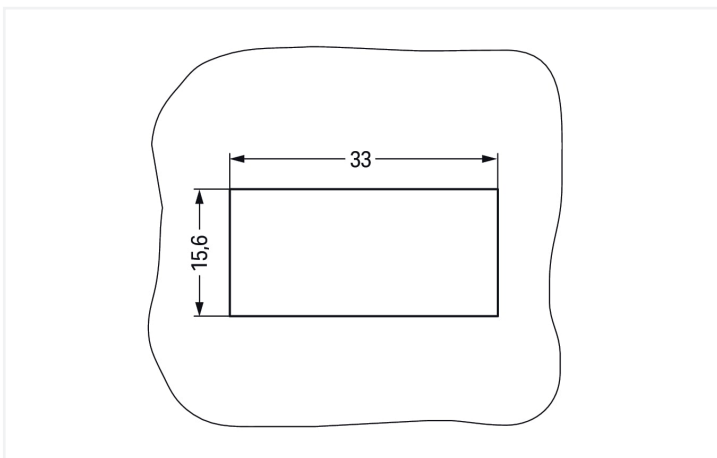

Dimensions in mm



Dimensions in mm

Plate thickness: 0.5 ... 2 mm

Cutout tolerance: + 0.1 mm

Please note!

Female connector/socket *WINSTA*® MIDI rated current 25 A

The *WINSTA*® MIDI female connector/socket with protection against mismatching is the pluggable solution for your application in control cabinets, for lighting connections or on PCBs. On PCBs, in control cabinets or for connecting lights – pluggable installation connectors from WAGO allow you to make connections according to a huge variety of requirements in next to no time. For greater protection in electrical installations, the pluggable installation connector is provided with mechanical protection against mismatching. The pluggable installation connector is protected against ingress by solid objects in accordance with protection type IP20 (When mated: IP2xC (These compact connectors are not designed for use in open, easily accessible areas!)). Thanks to the color coding and mechanical A coding of *WINSTA*® MIDI pluggable installation connectors, you can clearly distinguish different circuits. Important parameters in the selection of a pluggable installation connector are the rated current and voltage: They provide information about possible domains of use and applications. This product has a current rating of 25 A – therefore it is also suitable for high power loads. *WINSTA*® MIDI with Push-in CAGE CLAMP® spring pressure connection technology is used in a broad range of individual products you can use for quick, easy, secure, tailored electrical installation.

Push-in CAGE CLAMP® spring pressure connection technology – pluggable installation instead of laborious screw connections!

The *WINSTA*® Pluggable Connection System allows pluggable electrical installation. This significantly reduces the need for servicing and lowers costs. Choose durability and quality – with marking from WAGO makes the electrical installation of electrical components significantly easier.

- pluggable installation connectors with protection against mismatching
- pre-assembled versions
- with A coding for use in a large number of general mains applications
- ready to install and use immediately
- quick replacement of defective units during ongoing operation

Notes

Note	<p>The snap-in connectors must be relieved of tensile and transverse forces. A surface finish can influence the edge radius of the cutouts. This may affect the snap-in socket fit, so ensure an adequate fit before use. In addition, the punched edge should be on the inside for punched cutouts.</p> <p>The wings of the snap-in connectors must not be mechanically stressed for a long period before use (e.g., due to a pre-locking position).</p>
------	---

Electrical data

Ratings per	IEC/EN 60664-1			Approvals per	UL 1977
Overvoltage category	III	III	II	Rated voltage	600 V
Pollution degree	3	2	2	Rated current	23 A
Nominal voltage	250 V	-	-		
Rated surge voltage	4 kV	-	-		
Rated current	25 A	-	-		

General information

Note on contact resistance	approx. 1 mΩ of contact resistance approx. 0.25 mΩ contact transition plug/ socket
----------------------------	--

Connection data

Clamping units	6	Connection 1	
Total number of potentials	3	Connection technology	Push-in CAGE CLAMP®
Number of test slots	3	Actuation type	Operating tool Push-in
		Nominal cross-section	4 mm ² / 12 AWG
		Solid conductor	0.5 ... 4 mm ² / 20 ... 12 AWG
		Solid conductor; push-in termination	1.5 ... 4 mm ² / 16 ... 12 AWG
		Stranded conductor	0.5 ... 2.5 mm ² / 20 ... 14 AWG
		Fine-stranded conductor	0.5 ... 4 mm ² / 20 ... 12 AWG
		Fine-stranded conductor; with insulated ferrule	0.25 ... 1.5 mm ² / 20 ... 16 AWG
		Fine-stranded conductor; with uninsulated ferrule	0.25 ... 2.5 mm ² / 20 ... 14 AWG
		Fine-stranded conductor; with ferrule; push-in termination	1.5 mm ² / 16 AWG
		Strip length	9 mm / 0.35 inches
		Pole number	3
		Conductor entry direction to mating direction	0°

Physical data

Pin spacing	10 mm / 0.394 inches
Width	35.5 mm / 1.398 inches
Height	17.5 mm / 0.689 inches
Depth	37.5 mm / 1.476 inches

Mechanical data

Use	General mains applications
Coding	A
Variable coding	Yes
Marking	L N
Potential marking	L N
Mating force of a plug-in connection	approx. 20 ... 70 N (depending on pole number)
Retention force of a plug-in connection	Locked: > 80 N
Unmating force of a plug-in connection	Unlocked: approx. 20 ... 70 N (depending on pole number)
Number of mating cycles	200, without resistive load
Housing sheet thickness	0.5 ... 2 mm / 0.02 ... 0.079 inches
Mounting type	Snap-in flange
Protection type	IP20; When mated: IP2xC (These compact connectors are not designed for use in open, easily accessible areas!)

Plug-in connection

Contact type (pluggable connector)	Female connector/socket
Connector (connection type)	for conductor
Mismating protection	Yes
Note on mismating protection	All <i>WINSTA</i> ® components are 100% protected against mismating when: a.) plugging different numbers of poles b.) plugging while rotated 180 c.) plugging while laterally staggered d.) plugging one pole
Locking lever	Yes
Locking of plug-in connection	Locking lever
Note on locking system	All connectors for mounted installations (snap-in versions for lighting fixtures or devices, all types of PCB and distribution connectors) are factory-equipped with locking levers to ensure plugs and sockets are securely locked. Additional locking levers are only required for flying leads (plug/socket).

Material data

Note (material data)	Information on material specifications can be found here
Color	black
Insulation material (main housing)	Polyamide (PA66)
Flammability class per UL94	V0
Clamping spring material	Chrome-nickel spring steel (CrNi)
Contact material	Copper or copper alloy; surface-treated
Contact Plating	Tin
Fire load	0.237 MJ
Weight	11.9 g

Environmental requirements

Processing temperature	-5 ... +40 °C
Continuous operating temperature	-35 ... +85 °C
Note on continuous operating temperature	Insulating parts for temperatures ≤ 105 °C



Commercial data	
Product Group	20 (Winsta)
eCl@ss 10.0	27-44-06-02
eCl@ss 9.0	27-44-06-02
ETIM 9.0	EC002566
ETIM 8.0	EC002566
PU (SPU)	100 pcs
Packaging type	Box
Country of origin	DE
GTIN	4044918252560
Customs tariff number	85366990990

Environmental Product Compliance	
RoHS Compliance Status	Compliant, No Exemption

Approvals / Certificates

General approvals			Declarations of conformity and manufacturer's declarations								
  			<table border="1"> <thead> <tr> <th>Approval</th> <th>Standard</th> <th>Certificate Name</th> </tr> </thead> <tbody> <tr> <td>EU-Declaration of Conformity WAGO GmbH & Co. KG</td> <td>-</td> <td>-</td> </tr> </tbody> </table>			Approval	Standard	Certificate Name	EU-Declaration of Conformity WAGO GmbH & Co. KG	-	-
Approval	Standard	Certificate Name									
EU-Declaration of Conformity WAGO GmbH & Co. KG	-	-									
Approval	Standard	Certificate Name									
CCA DEKRA Certification B.V.	EN 61535	71-123228									
CCA DEKRA Certification B.V.	IEC 61535	NL -84761									
cURus Underwriters Laboratories Inc.	UL 1977	E45171									
cURus Underwriters Laboratories Inc.	UL 1059	E 45172									

Approvals for marine applications

  		
Approval	Standard	Certificate Name
ABS American Bureau of Shipping	-	19-HG1868589-PDA
DNV GL Det Norske Veritas, Germanischer Lloyd	-	TAE00001Z6
LR Lloyds Register	IEC 61984	LR22429487TA

Downloads

Environmental Product Compliance

Compliance Search			
Environmental Product Compliance 770-703			↓

Documentation

Bid Text			
770-703	19.02.2019	xml 2.89 KB	↓
770-703	08.06.2015	doc 23.00 KB	↓

CAD/CAE-Data

CAD data	
2D/3D Models 770-703	↓

CAE data	
EPLAN Data Portal 770-703	↓
WSCAD Universe 770-703	↓
ZUKEN Portal 770-703	↓

1 Compatible Products

1.1 System counterpart

1.1.1 Cable assembly



Item No.: 771-9993/206-101
pre-assembled connecting cable; Eca; Plug/open-ended; 3-pole; Cod. A; H05VV-F 3G 1.5 mm²; 1 m; 1,50 mm²; black



Item No.: 771-9993/006-101
pre-assembled interconnecting cable; Eca; Socket/plug; 3-pole; Cod. A; H05VV-F 3G 1.5 mm²; 1 m; 1,50 mm²; black

1.1.2 Male connector/plug



Item No.: 770-213
Plug; 3-pole; Cod. A; 4,00 mm²; black



Item No.: 770-113
Plug; with strain relief housing; 3-pole; Cod. A; 4,00 mm²; black



Item No.: 770-213/035-000
Plug; with strain relief housing; 3-pole; Cod. A; 4,00 mm²; black

1.2 Optional Accessories

1.2.1 Cover

1.2.1.1 Cover



Item No.: 770-201

Lockout cap; 12-pole, separable; for sockets; Plastic; black



Item No.: 770-221

Lockout cap; 12-pole, separable; for sockets; Plastic; white



Item No.: 770-643

Lockout cap; 3-pole; for cutouts; Plastic; black



Item No.: 770-693

Lockout cap; 3-pole; for cutouts; Plastic; white

1.2.2 Tool

1.2.2.1 Operating tool



Item No.: 770-383

Operating tool; 3-way; green



Item No.: 210-719

Operating tool; Blade: 2.5 x 0.4 mm; with a partially insulated shaft

Installation Notes

Conductor termination

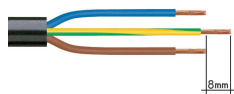

1. Strip length, outer insulation = 35 mm (2-pole), 55 mm (3- to 5-pole)
2. Strip length = 9 mm
3. Extended ground conductor = 8 mm

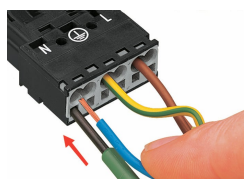

To terminate fine-stranded conductors, open the clamping unit via screwdriver (2.5 mm blade width) and insert a stripped conductor until it hits the backstop.

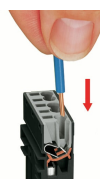

Insert the stripped solid conductor until it hits the backstop.



To terminate fine-stranded conductors, open the clamping unit via screwdriver (2.5 mm blade width) and insert a stripped conductor until it hits the backstop.

Conductor removal

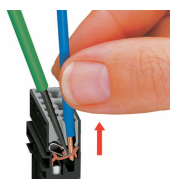

To remove the conductor, actuate the clamp via screwdriver (2.5 mm blade width) and pull out the conductor.



Seal unused cutout with lockout cap.