



All numerical values are in metric units [with U.S. customary units in brackets]. Dimensions are in millimeters [and inches]. Unless otherwise specified, dimensions have a tolerance of  $\pm 0.13$  [ $\pm 0.005$ ] and angles have a tolerance of  $\pm 2^\circ$ . Figures and illustrations are for identification only and are not drawn to scale.

**1. INTRODUCTION**

This specification covers design recommendations for use of the AMPOWER Wave Crimp System as a power distribution medium consisting of pre-assembled cable/connector assemblies and printed circuit (pc) board headers assemblies. The cable assemblies can be produced in any length and in a variety of configurations. The pc board headers are available with either solder tine or ACTION PIN\* Contacts, and for right-angle and vertical mount applications.

When corresponding with TE Connectivity Representatives, use the terminology provided in this specification to facilitate your inquiry for information. Basic terms and features of the cable connector and header assemblies are provided in Figure 1.

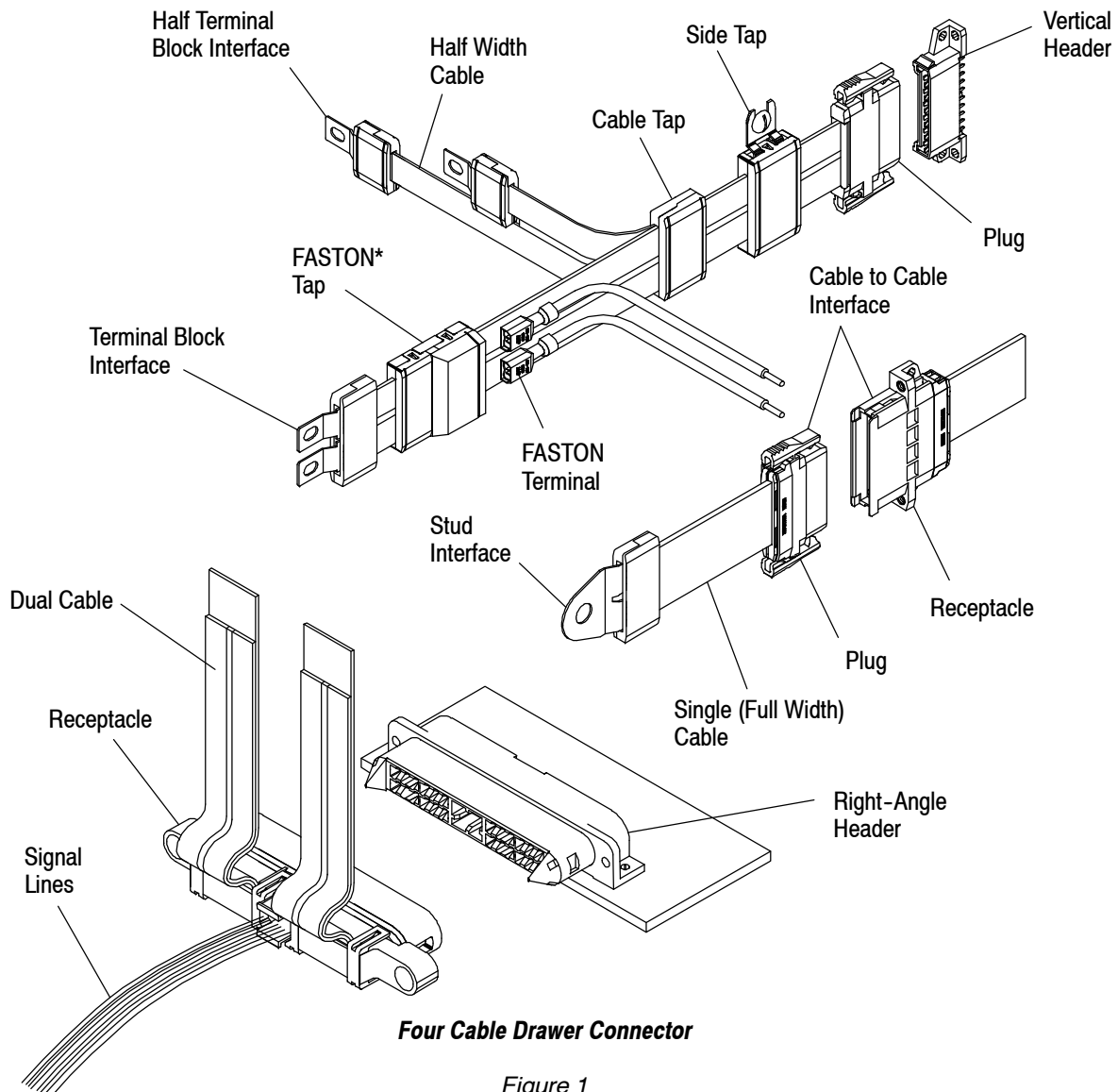

Figure 1

---

## 2. REFERENCE MATERIAL

### 2.1. Revision Summary

This paragraph is reserved for a revision summary of the most recent additions and changes made to this specification which include the following:

- Updated document to corporate requirements
- Added new text to Paragraph 3.8.A

### 2.2. Customer Assistance

Reference Part Number 765315 and Product Code 2842 are representative numbers of AMPOWER Wave Crimp System. Use of these numbers will identify the product line and expedite your inquiries through a service network established to help you obtain product and tooling information. Such information can be obtained through a local TE Representative, or by calling the Product Information number at the bottom of page 1.

### 2.3. Drawings

Customer Drawings for product part numbers are available from the service network. The information contained in Customer Drawings takes priority if there is a conflict with this specification or with any other technical documentation supplied by TE.

### 2.4. Product Specifications

Product specifications listed below are available for performance and test information.

<b>Product Specification</b>	<b>Product Description</b>
108-1308	Separable Interface (Full and Half Width)
108-1313	Terminal Block Interface
108-1315	Tap Interface—Cable
108-1319	Drawer Connector
108-1387	Tap Interface—.250 FASTON Tab
108-1391	Tap Interface—Side
108-1403	Right Angle Self Aligning Header
108-1408	Cable to Cable Interface
108-1410	ACTION PIN Header
108-1436	Cable to Cable Drawer Connector
108-1479	ACTION PIN Self Aligning Connector

### 2.5. Manuals

Manual 402-40 is available from the service network. This manual provides information on various flux types and characteristics along with the commercial designation and flux removal procedures. A checklist is included in the manual as required for information on soldering problems.

## 3. REQUIREMENTS

### 3.1. Cable Specifications

#### A. Size

The AMPOWER Wave Crimp System is based upon the use of commercially available flat insulated copper cable as characterized in Figure 2. All terminations of this system are one or two conductor channels, depending upon the choice of dual or single (full width) cable.

#### B. Preparation

TE currently offers only cable assemblies and board mount headers for sale. Some components are sold separately as replacement parts.

#### C. Folds

Folding of cables to route conductors for specific applications is a process inherent to this system. When re-routing or changing folds, it is permissible to refold a cable at right angles to an original fold only once.

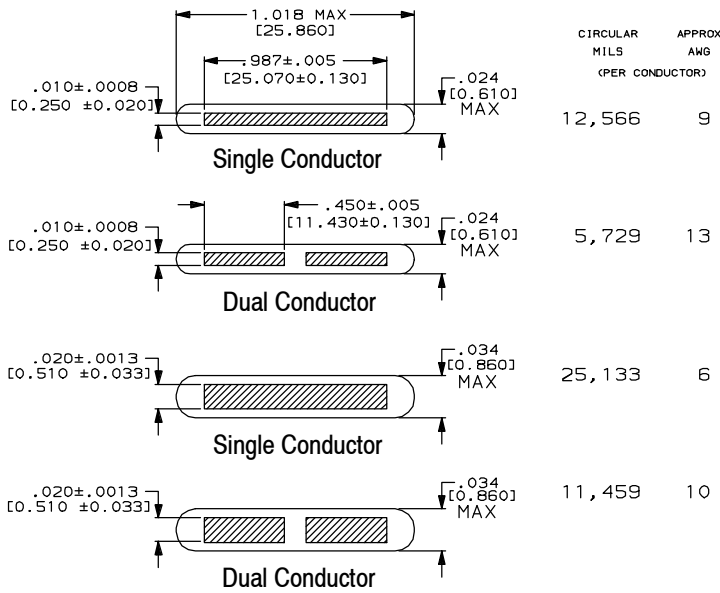

CABLE THICKNESS	RESISTANCE (MILLIOHMS)●	
	SINGLE	DUAL
0.51 [.020]	.456	.996
0.25 [.010]	.912	2.030

● The dc resistance of a 304.8 [12] length of conductor when measured at 25°C [77°F] and 10 AMPS shall be less than this figure in milliohms.

Figure 2

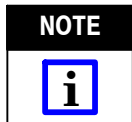

In order to determine the flex-life of flat cable in a specific application, call the Product Information number at the bottom of page 1 and request the TECH BRIEF on Flat Cable Service Loops.

**D. Splits**

Splitting of dual conductor cables is done in order to route conductors to nonadjacent points. Terminal block and plug interfaces are available to accommodate this capability. See Figure 3.

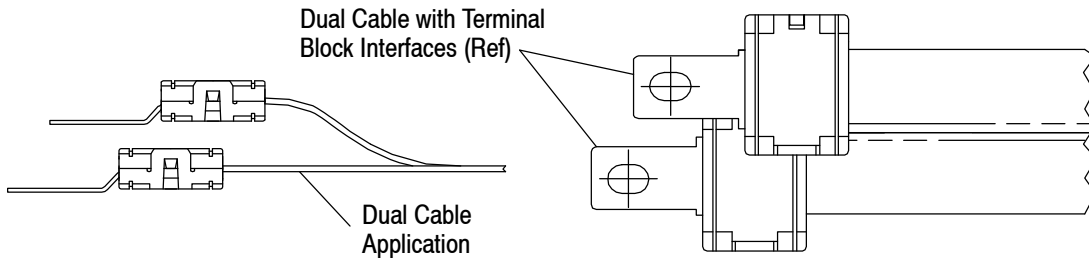

Figure 3

**E. Routing**

Proper cable support should be provided at critical points to minimize effects of vibration and other mechanical stresses. Cable assemblies can be provided with two or more cables held together by cable ties (for minimum inductance).

It is suggested that where multiple conductors are overlaid, a sequence of assembly be provided to manufacturing and assembly personnel.

Self aligning receptacles accept multiple cables which can be combinations of single and dual conductors, 0.25 and 0.51 [.010 and .020] thick. Cables may extend from the same side (lower inductance) or opposite sides (lower heat) of the connector with the strain relief holding them in position as shown in Figure 4.



Like any other insulated conductor, cables should be protected from sharp objects such as burred metal, screws, welds, etc.

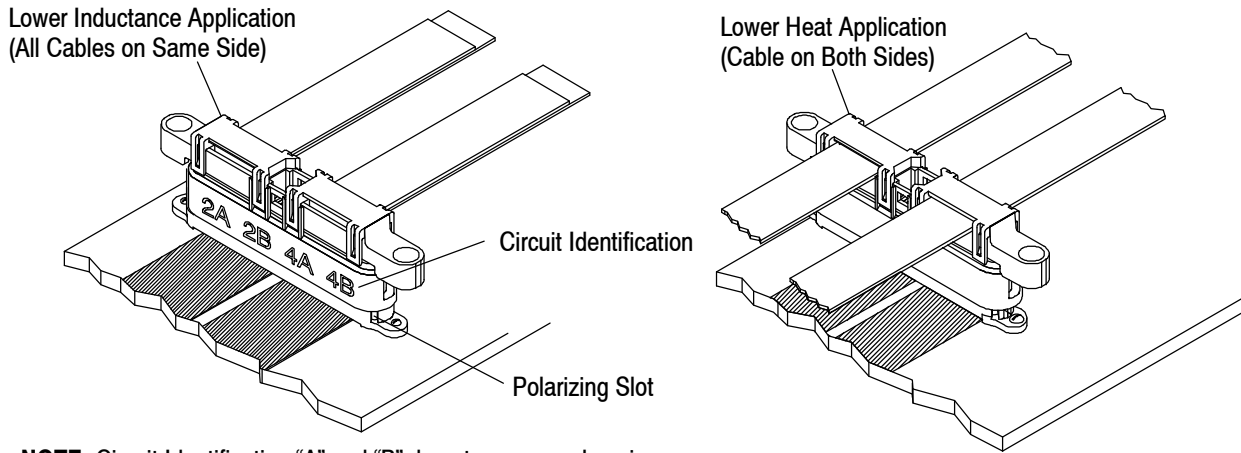

**NOTE:** Circuit Identification “A” and “B” do not appear on housing

Figure 4

## F. Impedance Characteristics

Digital systems present transient current demands to supply systems. These transient current demands will create voltage transients at the load as a function of the series inductance of the distribution circuit. These current transients will also complicate the power supply regulation circuitry.

These effects can be reduced in a power distribution network. The use of flat cable is a known means of reducing cable inductance. Calculated electrical parameters of AMPOWER flat cables compared with those of round solid conductors are shown in Figure 5.

Flat cables placed as close together as possible exhibit a characteristic impedance of approximately 3 ohms and an inductance of 17 nanohenries per meter. The flat conductors are separated by 0.36 [.014] of dielectric.

Round wires of equivalent conductor area placed as close together as possible exhibit a characteristic impedance of 75 ohms and an inductance of over 300 nanohenries per meter. The round wire conductors are separated by a total of 1.61 [.064] of dielectric.

Inductance of a co-planar dual cable pair circuits is nearly identical to that of two proximate insulated wires.

AIR GAP BETWEEN CABLES	ZERO	ZERO	0.51 [.020]	0.51 [.020]
CONDUCTOR (6 AWG)	0.51 [.020]	4.12 [.162]	0.51 [.020]	4.12 [.162]
INSULATION THICKNESS	0.18 [.007]	0.81 [.032]	0.18 [.007]	0.81 [.032]
C (nF/m)	1.6853	.05659	.37638	.04344
C <sub>O</sub> (nF/m)	.6606	.03459	.28364	.03065
E <sub>R eff</sub>	2.5512	1.6363	1.3269	1.4165
L (nH/m)	16.932	323.39	39.435	364.77
Z <sub>O</sub> (ohms)	3.17	75.59	10.24	91.64

**Notes:** Insulation Dielectric Constant = 2.6  $E_{R \text{ eff}} = C/C_O$   
Where C = Free Space Capacitance of the Wire Configuration

Figure 5

### 3.2. Lubrication

In order to assure the required durability of the AMPPOWER contacts, the plug of the separable interface is lubricated and therefore should not be exposed to solvents.

### 3.3. PC Board Layout

Right-angle and vertical mount headers are available with contacts on 2.54 [.100] centers. They will accommodate solder or press fit applications. See Figures 6 through 9 for pc board layouts.

Vertical mount self-aligning drawer headers feature an offset (0.72 [.030]) flange in order to provide polarization during assembly to the circuit board. See Figures 10, 12, 14, and 15 for pc board layout.

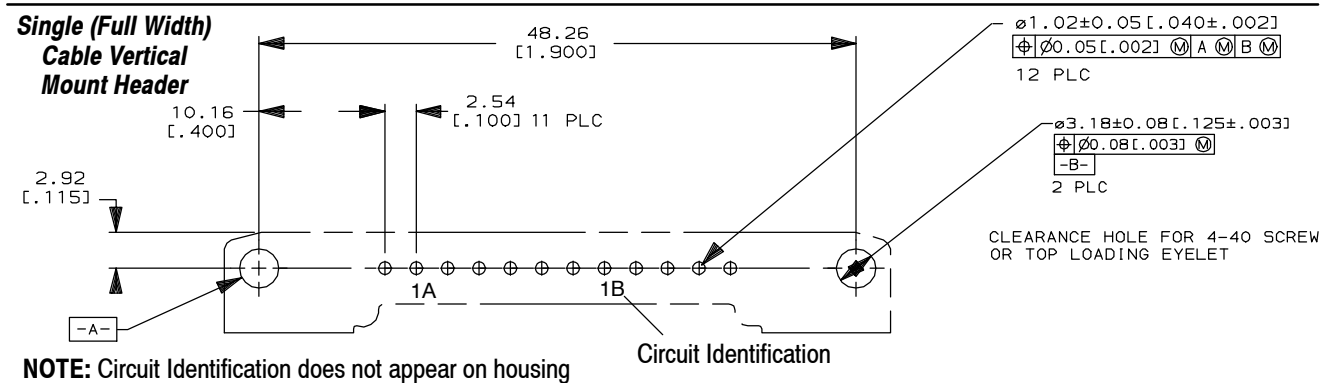

Figure 6

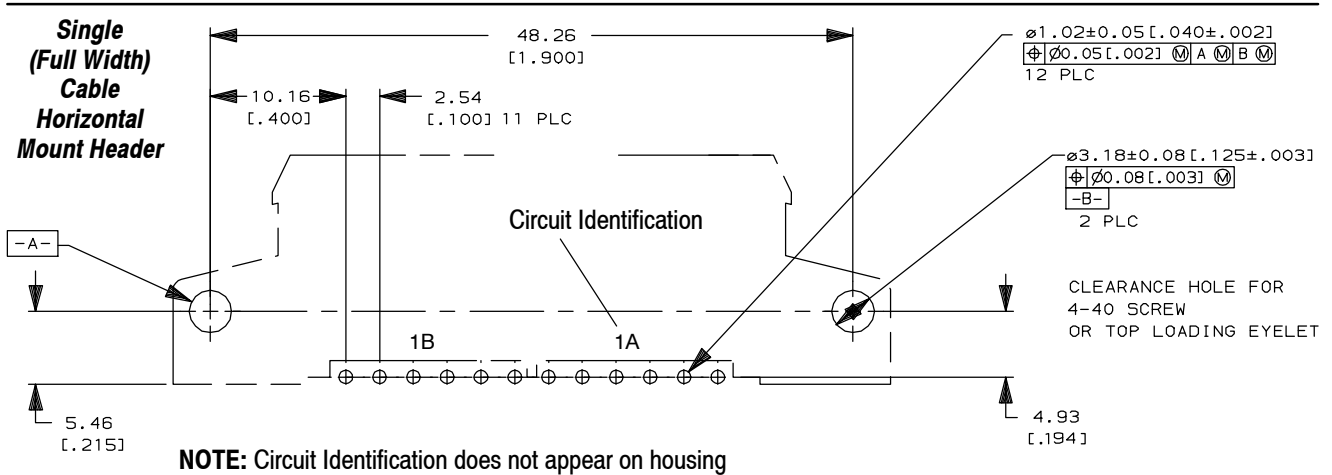

Figure 7

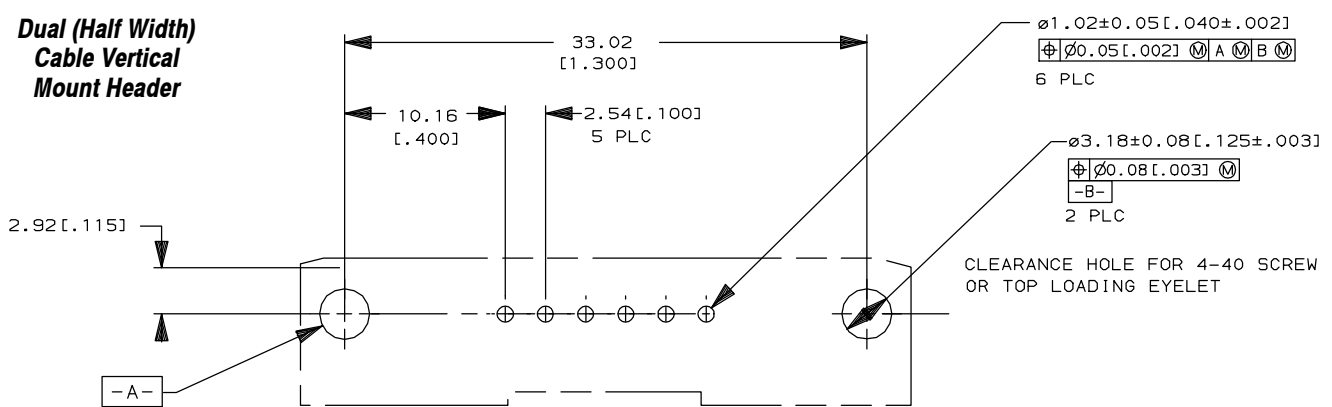

Figure 8

**Dual (Half Width)  
Cable Horizontal  
Mount Header**

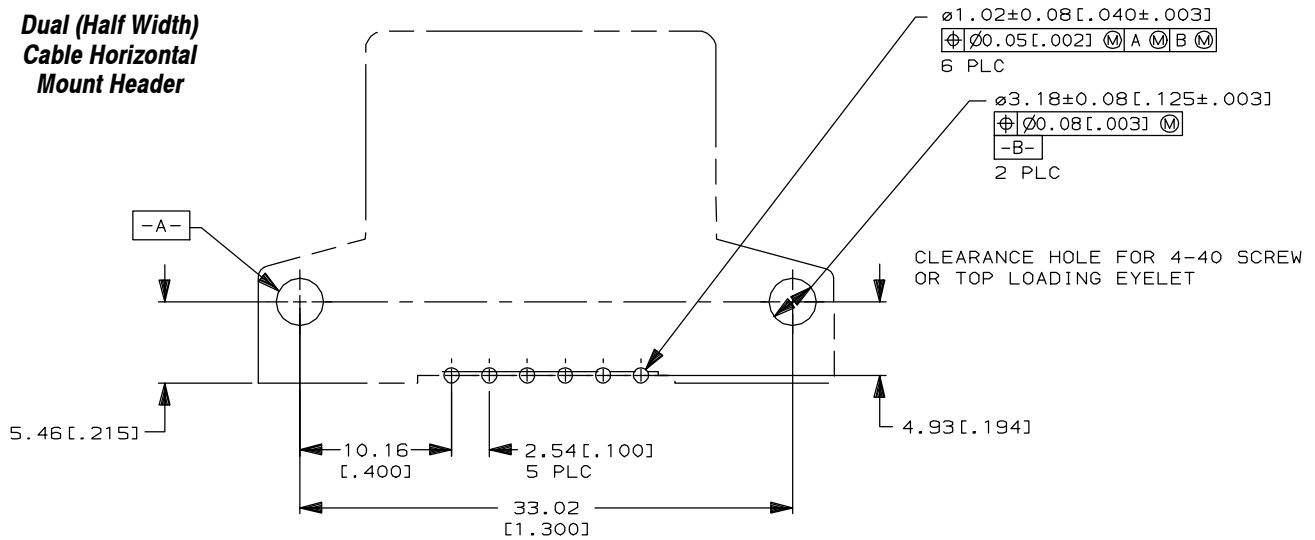
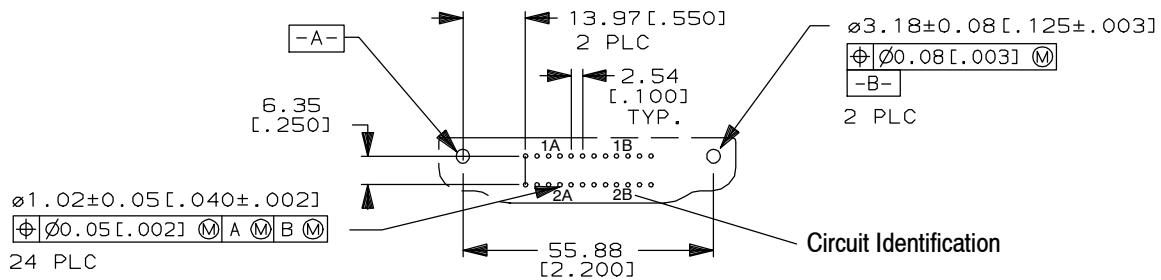

Figure 9

**Two Cable Self Aligning  
Vertical Mount Header**



**NOTE:** Circuit Identification "A" and "B" do not appear on housing

Figure 10

Self aligning, horizontal mount drawer headers are shown in Figures 11 and 13.

**Two Cable Self Aligning  
Horizontal Mount Headers**

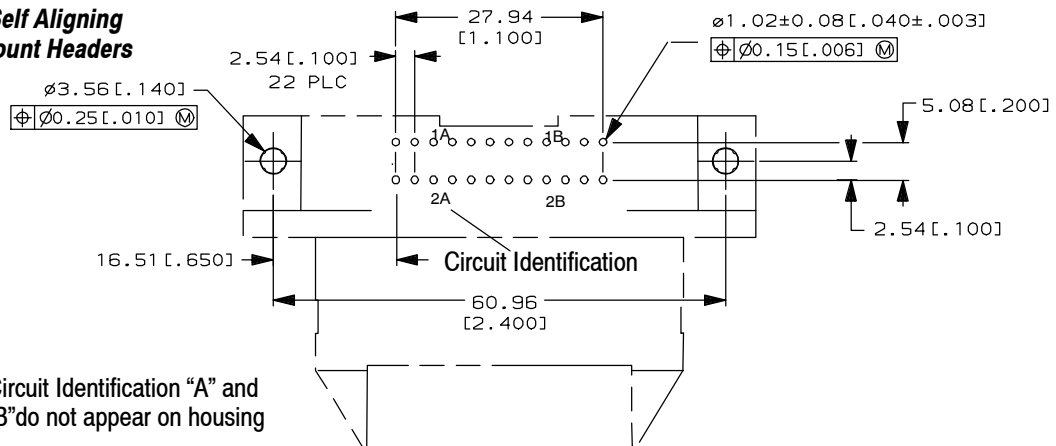

**NOTE:** Circuit Identification "A" and "B" do not appear on housing

Figure 11

**Four Cable Self Aligning Vertical Mount Header**

Figure 12

**Four Cable Self Aligning Horizontal Mount Header With Forty-Eight Sense Lines**

Figure 13

**Four Cable Self Aligning Vertical Mount Header With Eight Sense Lines**

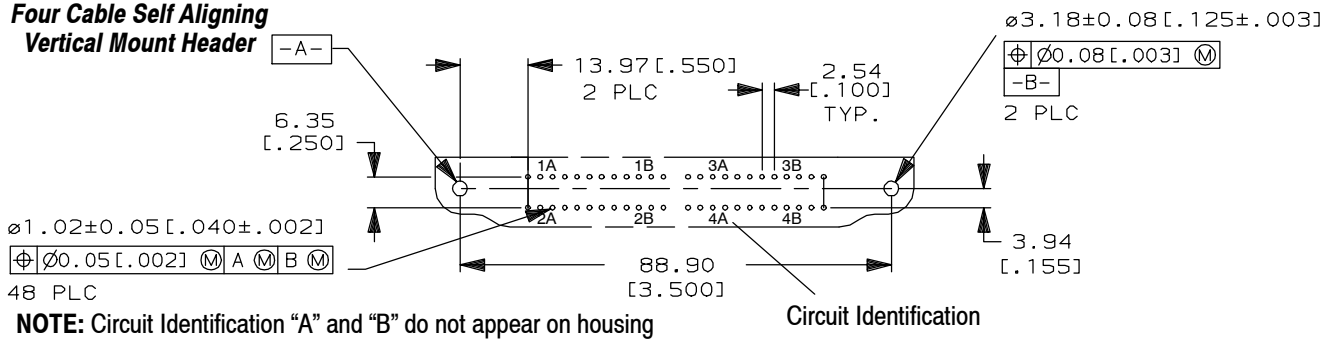
Figure 14

**Four Cable Self Aligning Vertical Mount Header With Twenty-One Sense Lines**

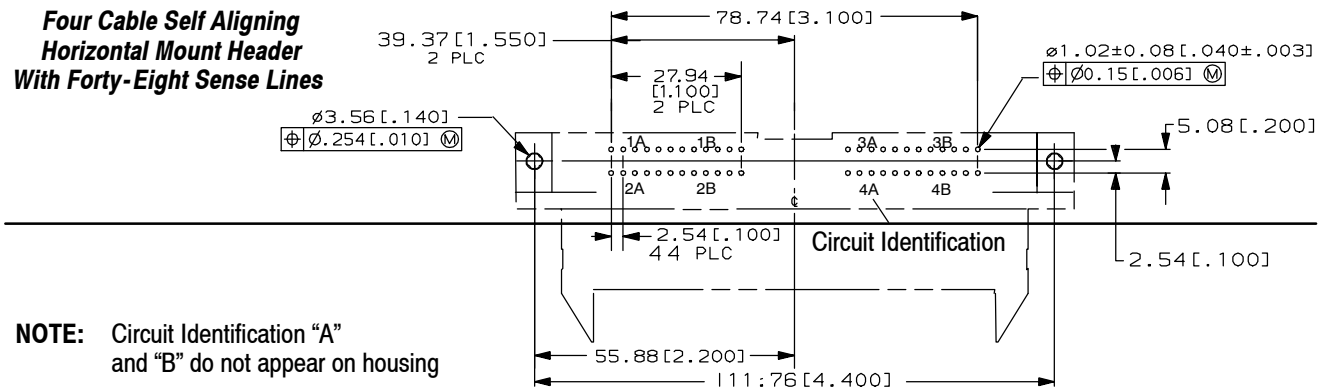
Figure 15

### 3.4. Polarization

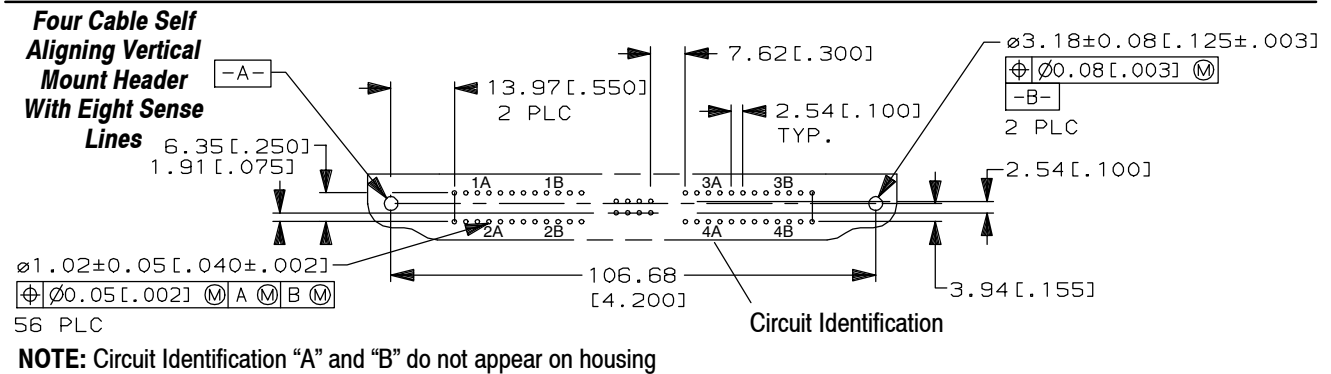
All separable interfaces have polarization design features that prevent inadvertent rotation of mating connectors.

### 3.5. Covers

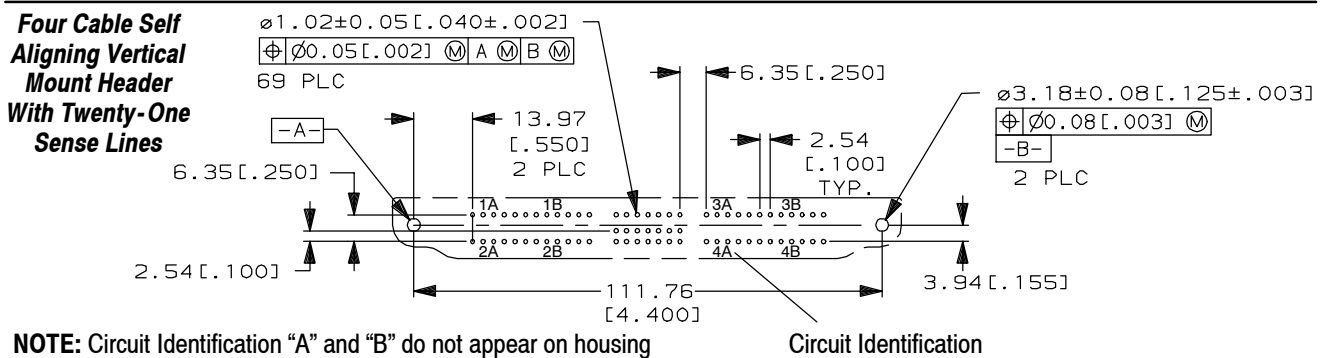
Covers must be kept securely in place as shown in Figure 16. They have no mechanical function relative to crimp performance.

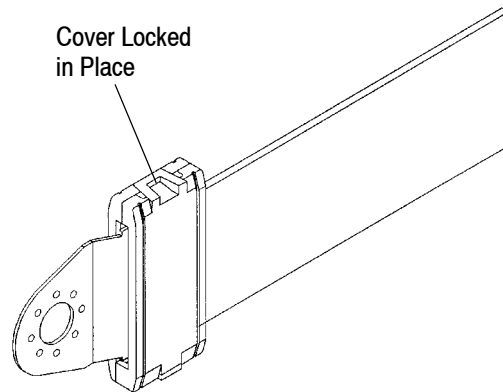

Figure 16

### 3.6. Mounting Hardware

#### A. Header Assemblies

Header flange holes will accept standard No. 4 pan head, round head, or socket head machine screws in combination with nuts and washers as desired. They are also compatible with top-activated, metal hold-down eyelets. Each eyelet is designed to be activated with a force of 20 pounds and provides retention to the pc board through the soldering operation. After filling with solder, it provides mechanical stability to the header. Activation tooling is described in Section 5. Optional cover for protection of exposed header leads is also shown in Figure 17.

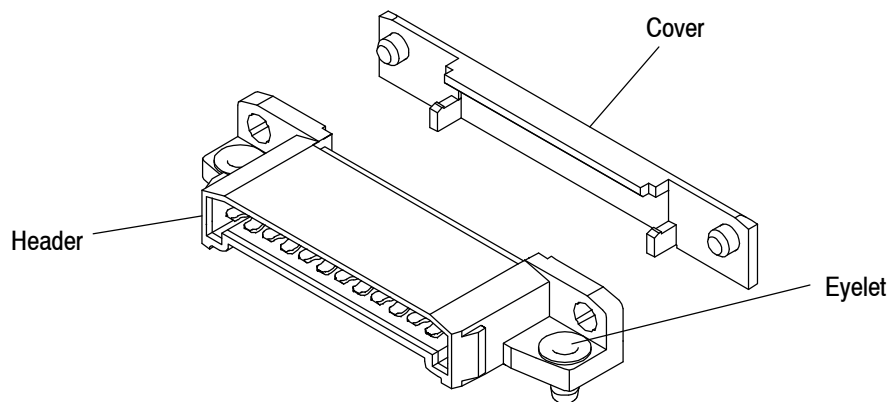

Figure 17

#### B. Receptacles (Self Aligning Connector only)

The receptacle, together with its mounting hardware and recommended panel cutout, were designed to permit 4.06 [.160] total diametric motion during mating. This is accomplished by the controlled fit between the receptacle mounting hole and the diameter of the shoulder screws which secure it. See Figure 18. For panel cutouts, see Figure 19. For torque recommendations, refer to Paragraph 3.6,C.

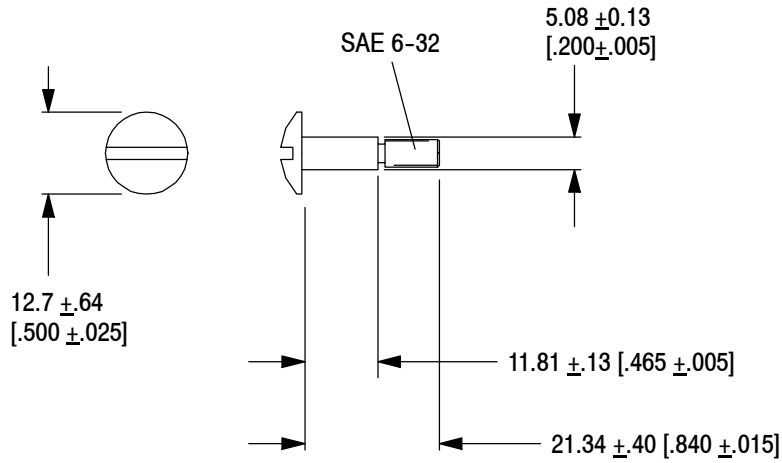
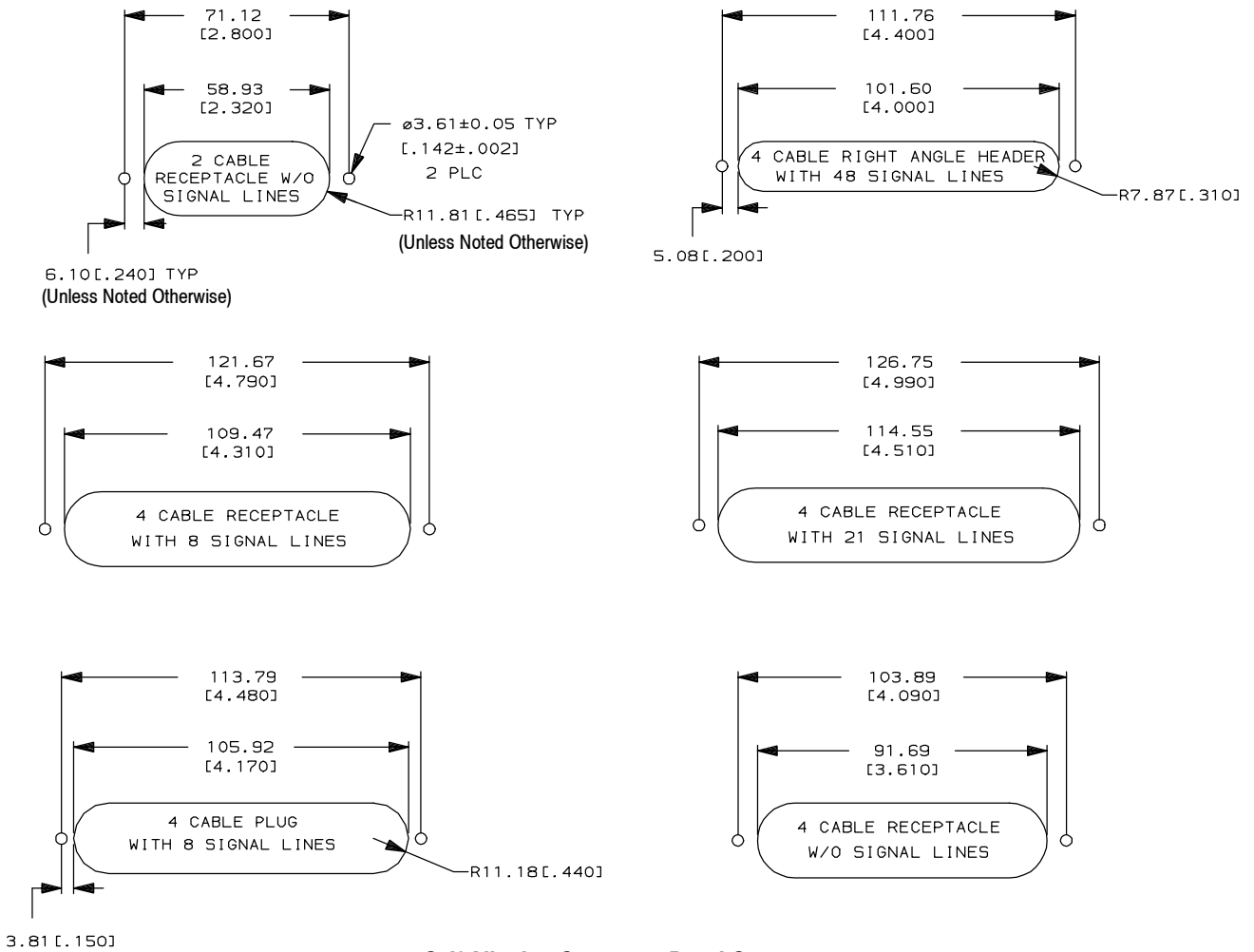

Figure 18



**Self Aligning Connector Panel Cutouts**

Figure 19

### C. Stud and Terminal Block Interconnection

The interface tab must be secured with a washer and a screw, or a bolt and nut to assure the high current interface is not degraded. Sufficient torque must be applied to studs or screws to ensure the long-term integrity of the interface. UL Specification 486A is referenced in Figure 20.

STUD/SCREW SIZE	TORQUE VALUE	
	NEWTON METERS	FOOT-POUNDS
NO. 8	2	1.5
NO. 10	3	2.0
1/4 INCH OR LESS	8	8.0
5/16 INCH	15	11.0
3/8 INCH	25	19.0
7/16 INCH	41	30.0
1/2 INCH	54	40.0
9/16 TO 5/8 INCH OR LARGER	75	55.0

Figure 20

### 3.7. Engagement

#### A. Full Engagement

Figure 21 shows the distance between header/plug and the receptacle mounting surfaces at full engagement of the housings.

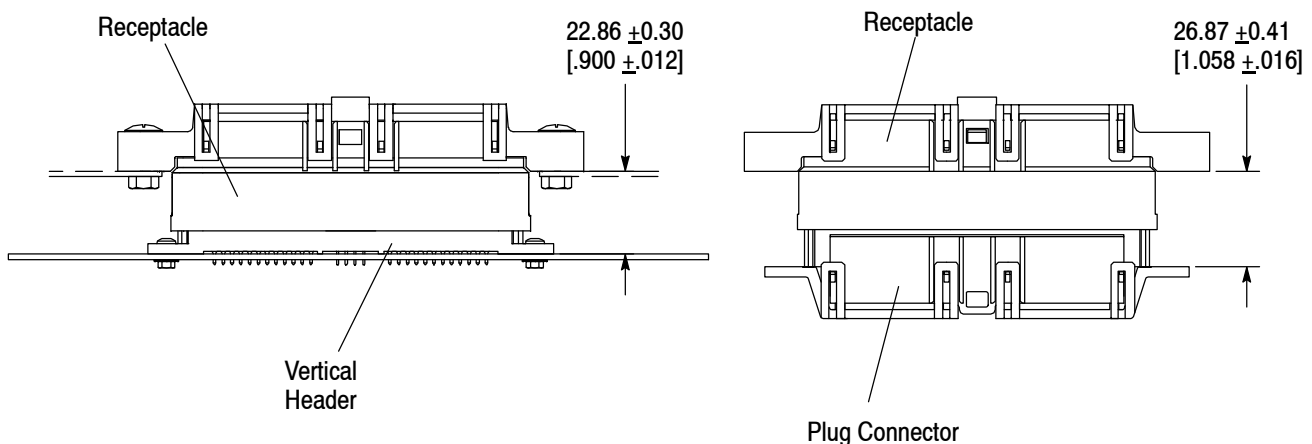

Figure 21

#### B. Sequential Engagement

Self-aligning drawer connectors are designed to provide sequential mating. The three sequences are represented by: (1) GROUND, (2) STD-SIGNAL/POWER and (3) SHORT-SIGNAL. Figure 22 shows distances and tolerances between vertical-header and receptacle mounting surfaces at each engagement position. Either power or ground contacts may be used on each single (full width) cable, but they cannot be mixed on the same cable. These can be used to ensure mate first, break last engagement and are suitable for software controlled HOT MATE applications. See Figure 22.

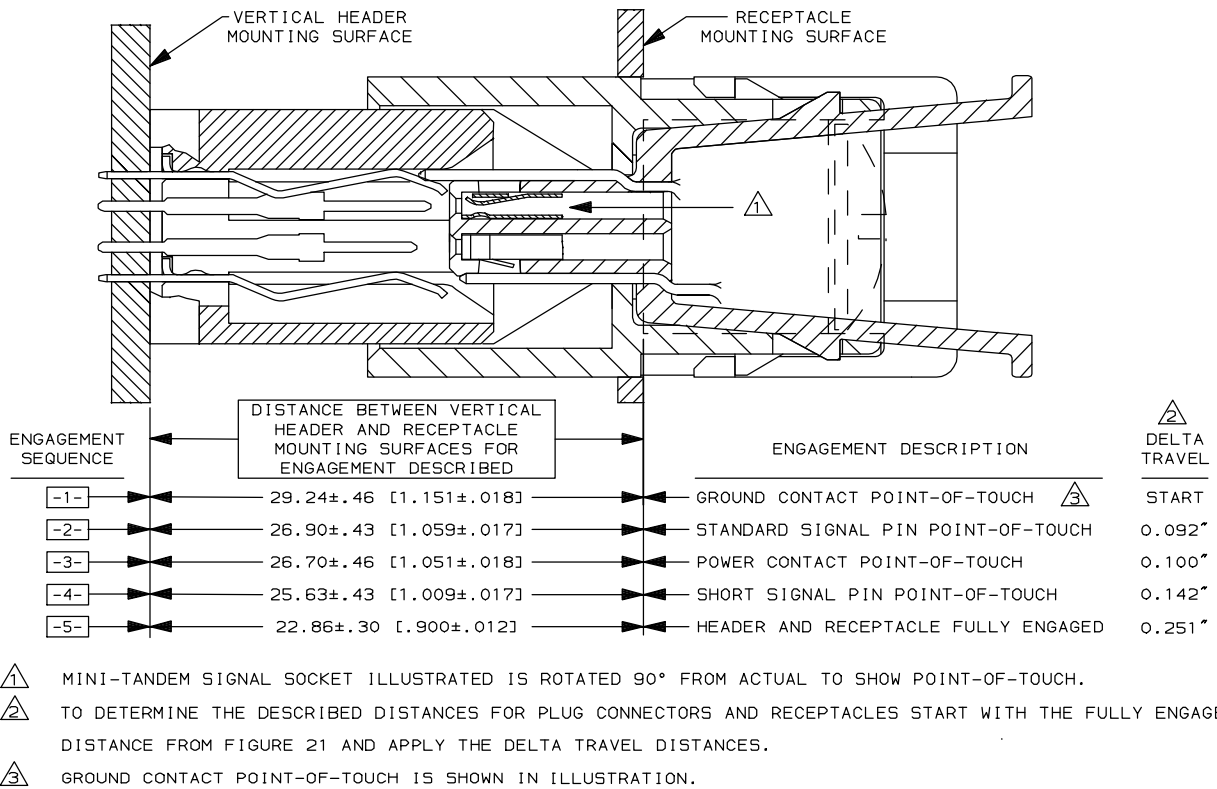

Figure 22

### 3.8. Soldering Headers

#### A. Flux Selection

Header solder tails should be fluxed with a non activated rosin flux (25% white rosin, 75% isopropyl alcohol) prior to soldering. Flux selection must be based on compatibility with other components used on the pc board assembly. All silver solder tails should be fluxed with mildly activated rosin prior to soldering. Reference TE document 109-11.

#### B. Cleaning

After soldering, removal of fluxes, residues, and activators is necessary. Consult with the supplier of the solder and flux for recommended cleaning solvents. The following is a listing of common cleaning solvents that will not affect the connectors for a period of 5 minutes at 41 °C [105 °F]. See Figure 23.

CLEANER		TIME (Minutes)	TEMPERATURE (Maximum)
NAME	TYPE		
ALPHA 2110	Aqueous	1	132°C [270°F]
BIOACT EC-7	Solvent	5	100°C [212°F]
Butyl CARBITOL	Solvent	1	Ambient Room
Isopropyl Alcohol	Solvent	5	100°C [212°F]
KESTER 5778	Aqueous	5	100°C [212°F]
KESTER 5779	Aqueous	5	100°C [212°F]
LONCOTERGE 520	Aqueous	5	100°C [212°F]
LONCOTERGE 530	Aqueous	5	100°C [212°F]
Terpene Solvent	Solvent	5	100°C [212°F]

Figure 23

**C. Drying**

When drying cleaned assemblies and pc boards, make certain that temperature limitations of -13 to 41 °C [55 to 105 °F] are not exceeded. Excessive temperatures may cause housing degradation.

**D. Soldering Guidelines**

Refer to Paragraph 2.5 for instructional material that is available for establishing soldering guidelines.

**3.9. Designer Guidelines for Resistance**

Resistance values for connectors terminated to 25.4 [1.00] wide cable are provided in Figure 24.

**Separable Board Interface**

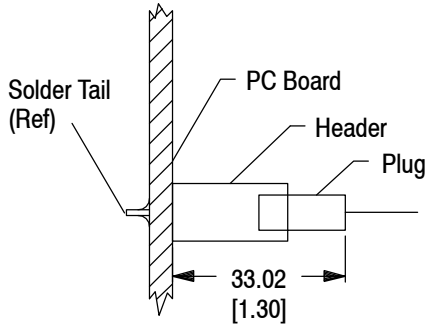

R-TOTAL		
CABLE THK	SINGLE (MILLIOHMS)	DUAL (MILLIOHMS)
0.51 [.020]	.225	.450
0.25 [.010]	.250	.500

**Tap Interface**

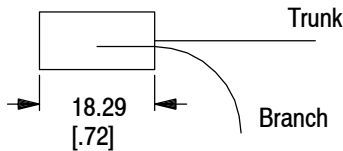

R-TRUNK		
CABLE THK	SINGLE (MILLIOHMS)	DUAL (MILLIOHMS)
0.51 [.020]	.035	.070
0.25 [.010]	.070	.140

R-BRANCH		
CABLE THK	SINGLE (MILLIOHMS)	DUAL (MILLIOHMS)
0.51 [.020] □	.080	.120
0.25 [.010] □	.150	.300
0.25 [.010] ☒	.175	.350

□ 0.51 [.020] Main Cable  
☒ 0.25 [.010] Main Cable

**Terminal-Block Interface**

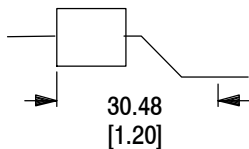

R-TOTAL		
CABLE THK	SINGLE (MILLIOHMS)	DUAL (MILLIOHMS)
0.51 [.020]	.055	.110
0.25 [.010]	.080	.160

**Self-Aligning Connector**

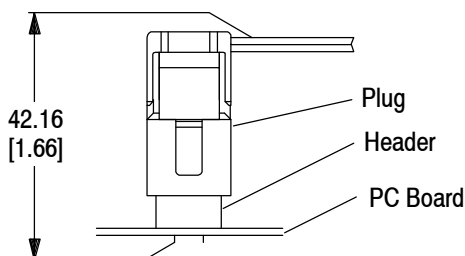

R-TOTAL		
CABLE THK	SINGLE (MILLIOHMS)	DUAL (MILLIOHMS)
0.51 [.020]	.250	.500
0.25 [.010]	.280	.560

**Note:**  
All Dimensions are Between  
Electrical Measurement Points

Figure 24

### 3.10. Current Carrying Capability

This information is provided as a guideline to users attempting to predict application performance of the AMPPOWER Wave Crimp System. Responsibility for performance in specific applications rests with the system designer.

The curves in Figures 25 through 30 illustrate actual measured values of current and temperature generated with components of the AMPPOWER Wave Crimp System in still air. It is important to recognize that this information results from specific configurations as noted earlier and is intended to isolate the particular component indicated. Variation in the specified configuration will act to improve or degrade the performance characterized here.

**NOTE**

Where cable is referred to as DUAL, the data refers to one-half width (11.43 [.450]) conductor. Single (full width) (25.4 [1.00]) capacity is obtained by doubling current indicated.

**CAUTION**

Performance indicated is not de-rated. Actual measurements of initial conditions are represented. All components represented in Figures 26 through 30 were evaluated as singular components. The current capacity of an assembly may be lower.

#### A. Single and Multiple Cable

Still air temperature rise is measured on a single long cable suspended horizontally 50.8 [2.000] above a pc board reference surface which is at room temperature.

The temperature rise in a long cable results from an equilibrium between internal Joule heating and external heat loss through the cable surface. There is no axial heat flow. T-rise data for a particular long cable may be successfully scaled to other flat geometries by requiring that the total cable dissipation at a particular temperature be equivalent to the surface area of the new cable configuration.

This leads to some useful rules-of-thumb:

1. Single cable current capacity is proportional to the square root of conductor thickness.
2. Individual conductor current capacity in a stack of identical cables is inversely proportional to the square root of the number of cables in the stack. This simple rule is effective for stacks up to about six or eight cables. Beyond that range, a more accurate prediction requires taking the sidewall area of the stack into account.

Figure 25 assumes that a 30°C [86°F] temperature rise is the maximum desirable. The table indicates the total current which can be carried by increasing increments of 0.25 [.010] thickness. The curve shows the actual temperature of the stack, when the total applied current is only a percentage of the level required for a rise of 30°C [86°F].

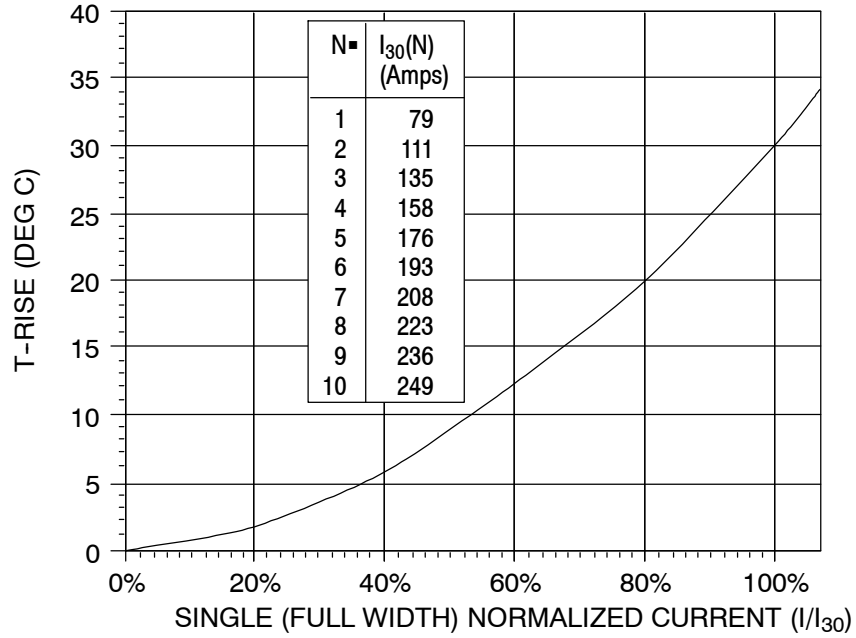

**Universal Stacked Cable T-Rise Curve**

▪ N=Number of 0.25 [.010] conductors.

Figure 25

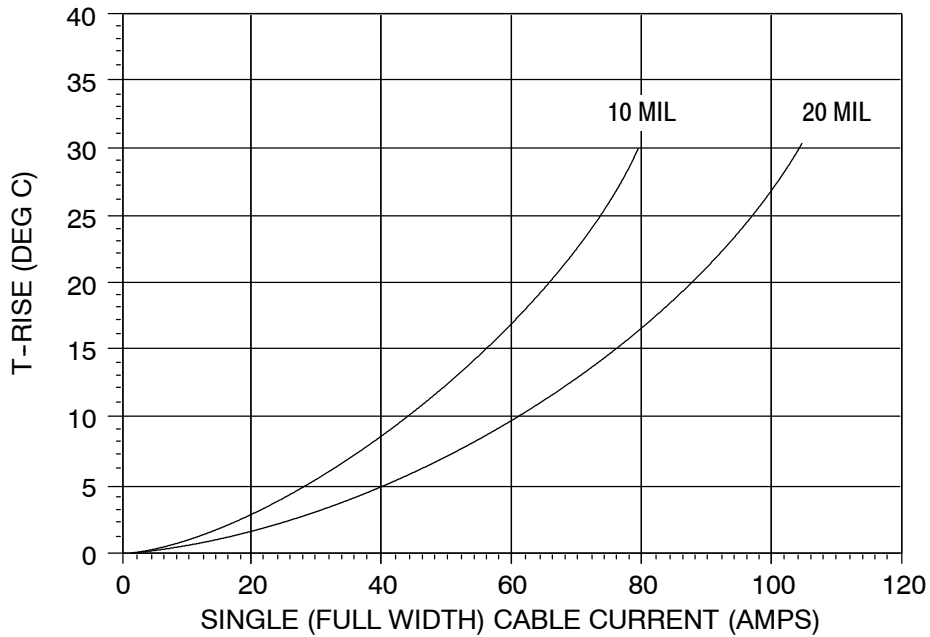

**Stud and Terminal Block Interface**

Figure 26

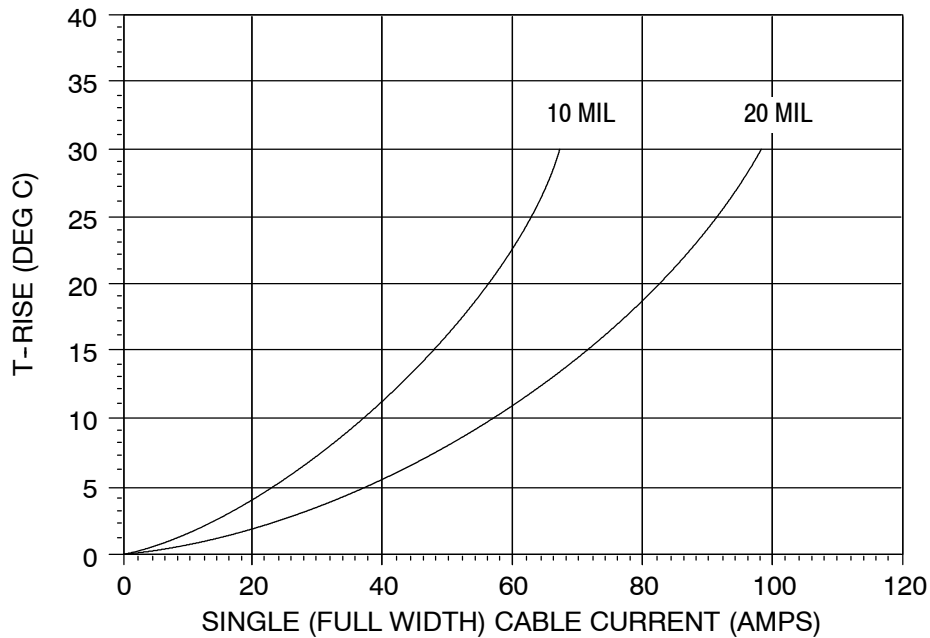

**Cable Tap Interface**

Figure 27

### B. Separable Interface

Figures 28 and 29 present measured T-rise data for a header/plug connector mounted on a pc board and interfaced to 0.25 [.010] and 0.51 [.020] flat cable. The performance of vertically and horizontally mounted headers is nearly identical. These tests were carried out on vertical headers using dual cable, with both circuits carrying equal current. Single (full width) cable current is the sum of the two channel currents. Test details are provided in the applicable Product Specification, but the basic geometry is a 88.9 x 304.8 x 1.52 [3.50 x 12 x .06] FR4, single-sided pc board with a header soldered to the foil at each end. The board is mounted horizontally in still air, 50.8 [2.00] above a reference surface, and is fed with cables that are 609.6 [24.00] long. Larger test boards yield higher performance but are unwieldy for product qualification. A long foil board that is 28 g, 127 mm wide [1 oz, 5 in. wide] is an approximate current capacity match for 20-mil single (full width) cables, and is a plausible measurement standard. Separable interface testing on a 139.7 x 609.6 [5.5 x 24], five-ounce board yields a 30°C [86°F] interface T-rise at 110 amperes. The temperature of the pc board foil near the header solder tails is below that of the connector interface except on 28 g [1 oz.] foil where the foil can run 5°C [9°F] warmer at an interface temperature of 30°C [86°F].

Solder tine temperature values are required by the board designer to ensure that board traces remain within an acceptable margin of the board temperature limit during continuous operation. The solder tine temperature is determined in large measure by the board foil geometry and thickness, and variations do not follow in direct one-to-one relationship in the separable interface temperature.

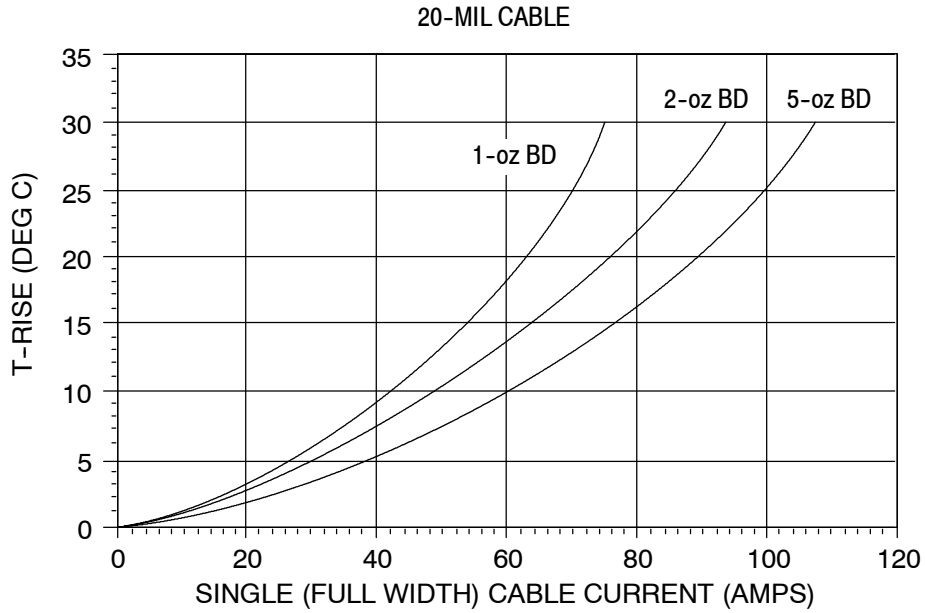

**Plug/Header Terminated to 0.51 [.020] Flat Cable and Mounted on PC Board**

Figure 28

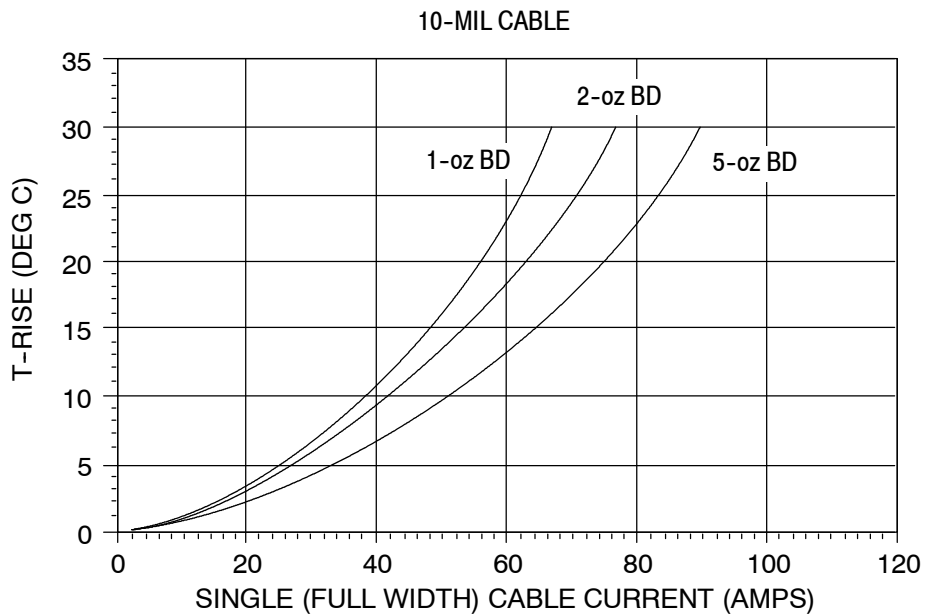

**Plug/Header Terminated to 0.25 [.010] Flat Cable and Mounted on PC Board**

Figure 29

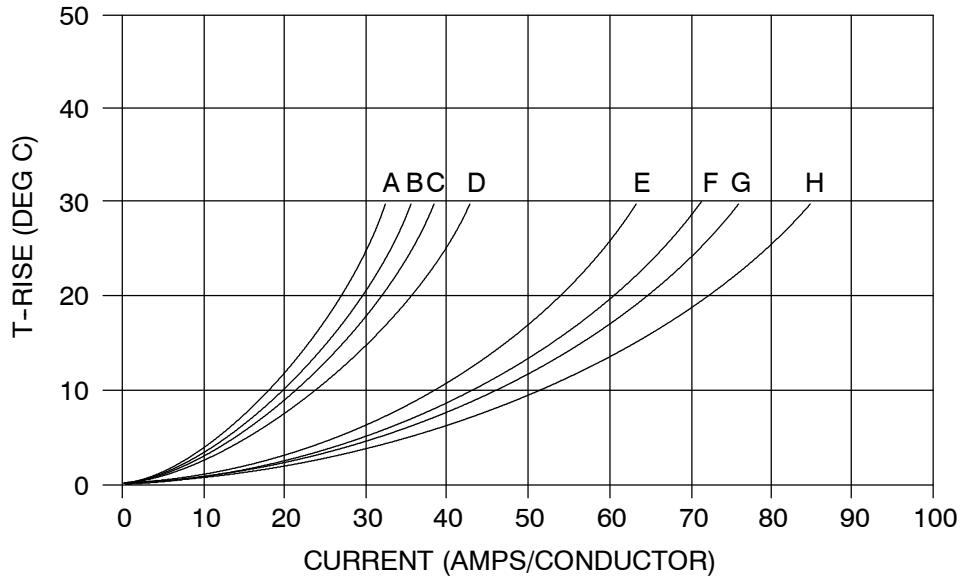

**Legend**

- |   |  |   |  |
|---|--|---|--|
| A | 0.25 [.010] Dual conductor with cables together  | E | 0.25 [.010] Single conductor with cables together  |
| B | 0.25 [.010] Dual conductor with cables separated | F | 0.25 [.010] Single conductor with cables separated |
| C | 0.51 [.020] Dual conductor with cables together  | G | 0.51 [.020] Single conductor with cables together  |
| D | 0.51 [.020] Dual conductor with cables separated | H | 0.51 [.020] Single conductor with cables separated |

**Current Carrying Capability of Self Aligning Connectors**

Figure 30

**C. Self Aligning Drawer Connector**

The temperature rise for a fixed current is related to the cable routing as illustrated in Figure 30. Connectors represented by data in Figure 30 have all circuits loaded in series. Headers were mounted by through-hole solder attachment to 2.36 [.093] thick, double sided 141.75 g [5.0 oz.] circuit boards. Maximum current of 344 amps requires 4 x 0.51 [.020] cables in the separated configuration. This involves 283.5 g [10 oz.] of copper, with current distribution in all directions from the centrally mounted header.

**3.11. Signal Modules**

Self-aligning connectors are available with 8 and 21 remote sense lines. These discrete lines are terminated with Mini Tandem Spring Contacts used in modules that are plugged into housings. See Figure 31.

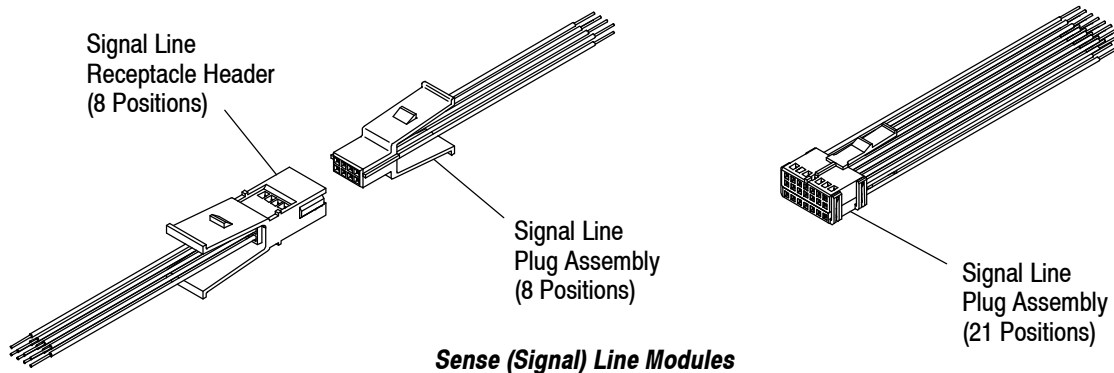

Figure 31

### 3.12. Component Spacing

Minimum spacing between mid cable terminations is 24.13 [.950] between components (or 44.45 [1.750] centerline pitch). Exceptions are FASTON-Taps which require 57.15 [2.225] centerline pitch and Reverse-Taps shown below. Spacing between Mid Cable and End Cable components can be no less than 44.45 [1.75].

#### A. Tap Connectors

Tap connectors can be attached to the trunk cable to form a branch line. The minimum dimension between tap connectors is provided in Figure 32.

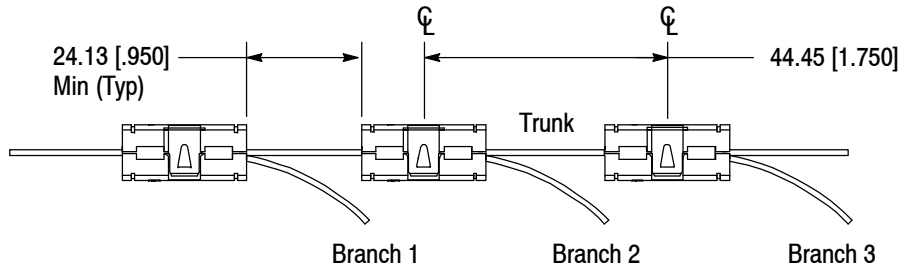

**Cable Tap Minimum Spacing**

Figure 32

#### B. Reverse-Side-Tap

Side taps can be attached in-line or in reverse of each other. The termination equipment used to attach taps requires a minimum dimension of 63.5 [2.500] between reverse-side-taps as shown in Figure 33.

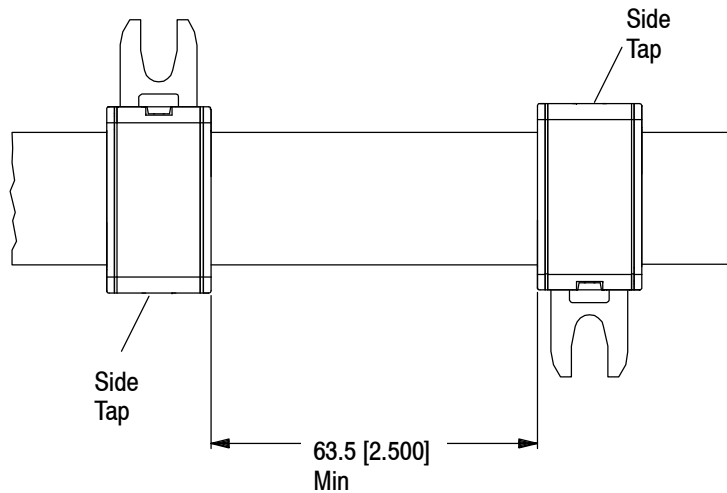

**Reverse-Side-Tap Minimum Spacing**

Figure 33

## 4. QUALIFICATIONS

AMPOWER Wave Crimp System Assemblies are Recognized by Underwriters Laboratories Inc. (UL) in File E28476, E13288, and E53799 and Certified by CSA International in File LR 7189, A-149,358, and LR 16455 class 5852.

**5. TOOLING**

**5.1. Eyelet Activation Tool**

The eyelet can be activated with a simple push tool design consisting of a handle and rod. See Figure 34 for the dimensions recommended for constructing the tool.

**5.2. PC Board Support**

A pc board support should be used to prevent bowing during formation of the eyelets. It should have a flat surface with holes or a channel large enough to clear the eyelet after formation. See Figure 34.

**5.3. Compliant Pin**

ACTION PIN contacts require tooling for insertion of contacts into circuit board plated through holes. Tools may be purchased from TE, or drawings will be furnished for customer fabrication. See Instruction Sheet 408-9848 for part numbers and proper usage. ACTION PIN sense line header contacts are replaceable using tools from TE as described in Instruction Sheets 408-9185 and 408-2636-1.

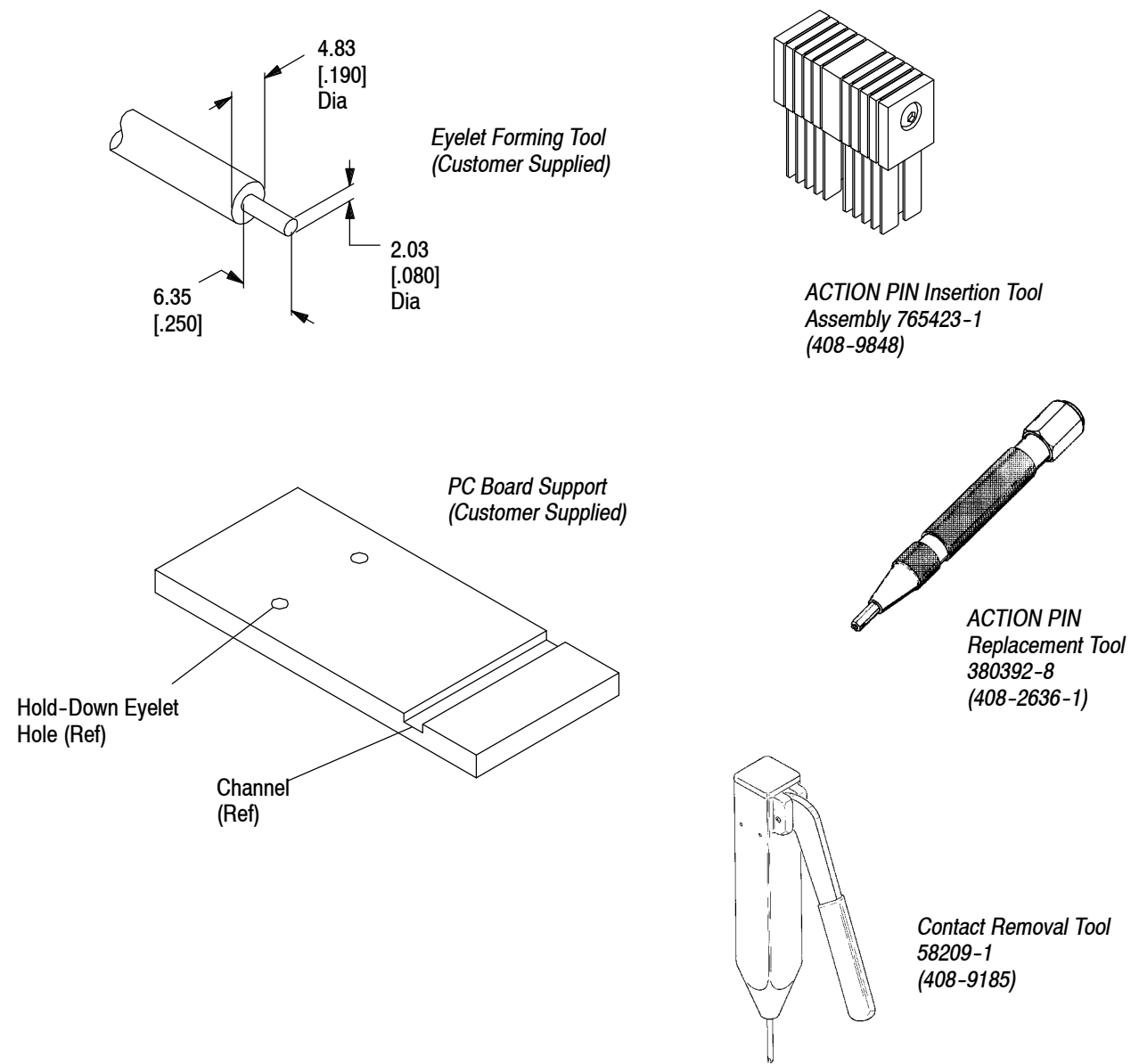
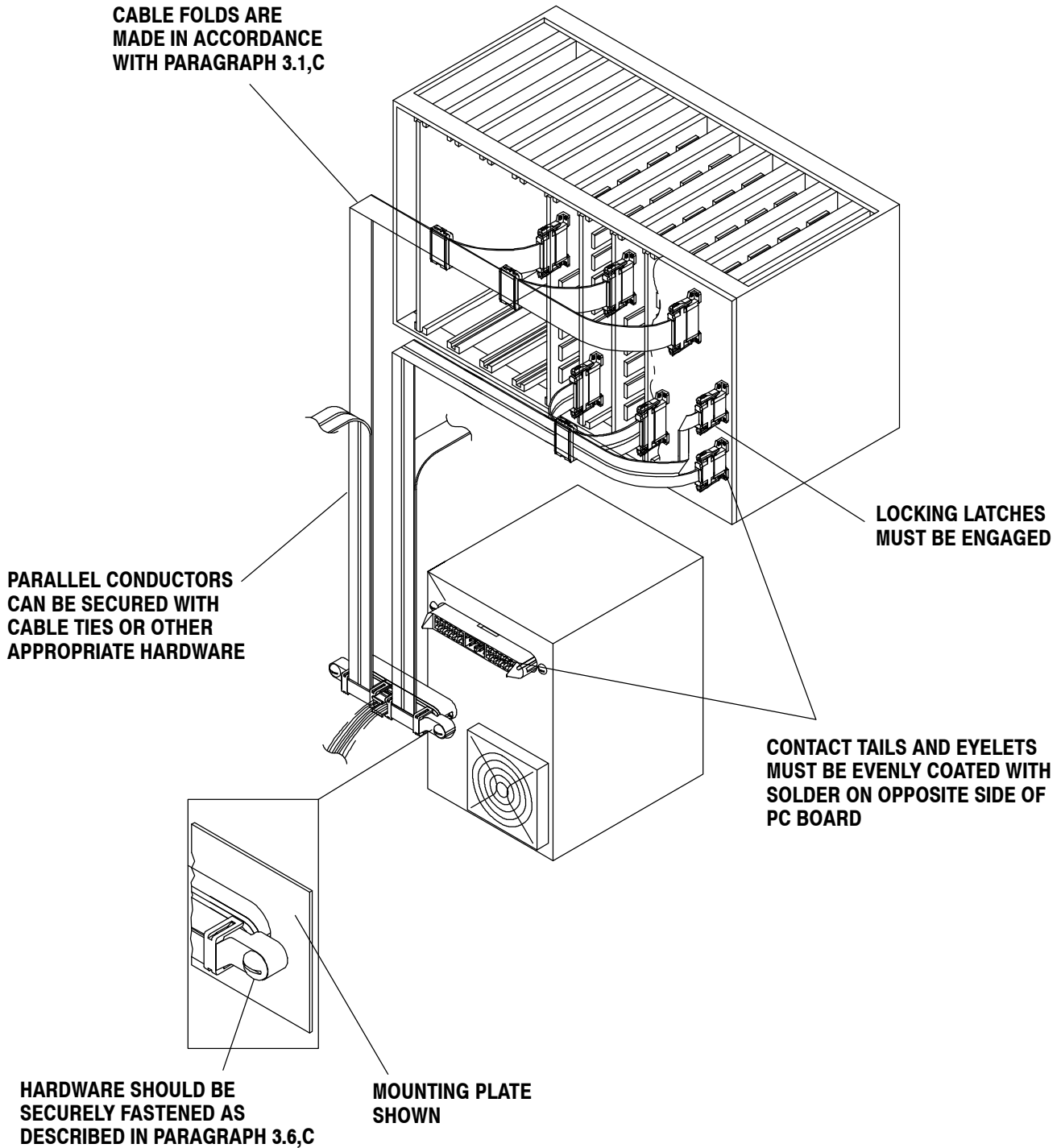

Figure 34

**6. VISUAL AID**

Figure 35 shows a typical application of AMPPOWER Wave Crimp System. This illustration should be used by production personnel to ensure a correctly applied product. Applications which DO NOT appear correct should be inspected using the information in the preceding pages of this specification and in the instructional material shipped with the product.



**FIGURE 35. VISUAL AID**