

Up to PL e of EN ISO 13849-1 PNOZ s10



Contact expansion module for increasing the number of available contacts

Approvals

	PNOZ s10
	◆
	◆
	◆

Unit features

- ▶ Positive-guided relay outputs:
 - 4 safety contacts (N/O), instantaneous
 - 1 auxiliary contact (N/C), instantaneous
- ▶ Safe separation of safety contacts from all other circuits
- ▶ LED indicator for:
 - Input status, channel 1
 - Input status, channel 2
 - Switch status, safety contacts
 - Error
- ▶ Plug-in connection terminals (either spring-loaded terminal or screw terminal)

Unit description

The unit meets the requirements of EN 60947-5-1, EN 60204-1 and VDE 0113-1. The contact expansion module is used to increase the number of instantaneous safety contacts available on a base unit. Base units are all safety relays with feedback loop monitoring.

The category that can be achieved in accordance with EN 954-1 and EN ISO 13849-1 depends on the category of the base unit. The contact expansion module may not exceed this.

Safety features

The unit meets the following safety requirements:

- ▶ The contact expansion module expands an existing circuit. As the output relays are monitored via the base unit's feedback loop, the safety functions on the existing circuit are transferred to the contact expansion module.
- ▶ The safety function remains effective in the case of a component failure.
- ▶ Earth fault in the feedback loop: Detected, depending on the base unit that is used.
- ▶ Earth fault in the input circuit: The output relays de-energise and the safety contacts open.

Block diagram

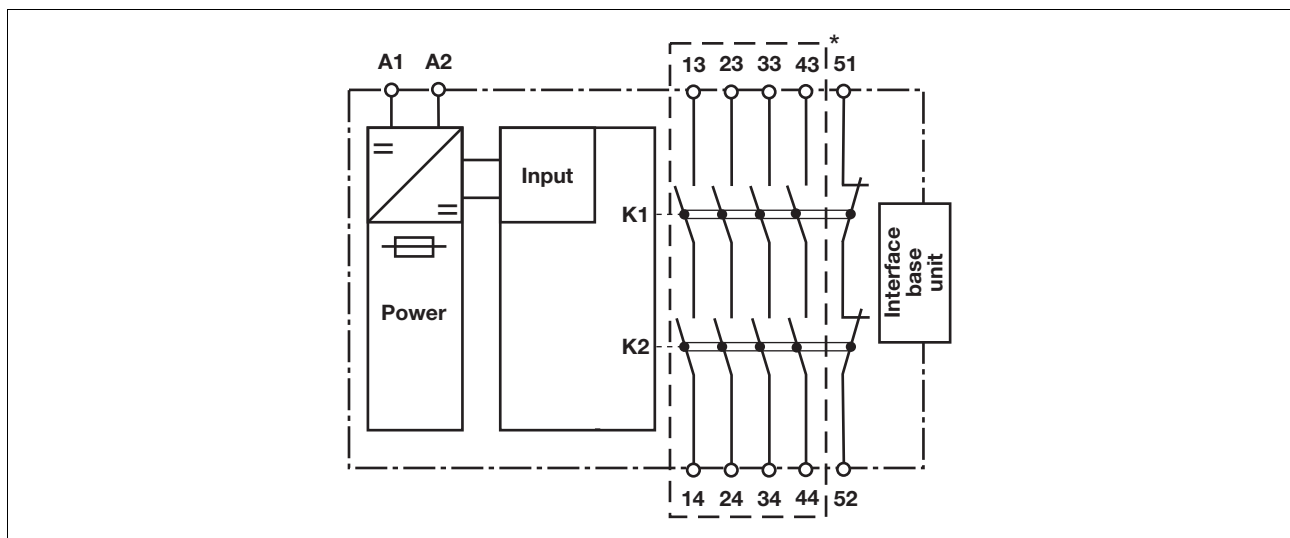

* Safe separation in accordance with EN 60947-1, 6 kV

Up to PL e of EN ISO 13849-1 PNOZ s10

Function description

with PNOZsigma base unit:

- ▶ Dual-channel operation via PNOZsigma connector

without PNOZsigma base unit:

- ▶ Single-channel operation: one input circuit affects the output relays

Timing diagram

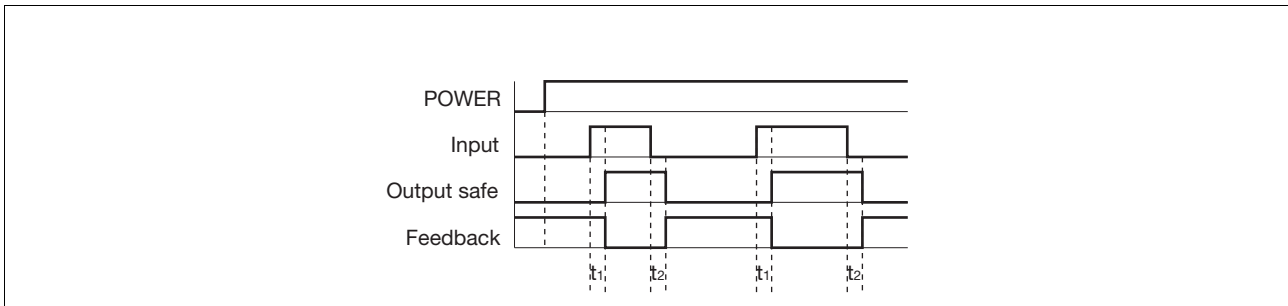

Key

- ▶ Power: Supply voltage
- ▶ Input: Input circuits A1
- ▶ Output safe: Safety contacts 13-14, 23-24, 33-34, 43-44
- ▶ Feedback: Feedback loop 51-52
- ▶ t₁: Switch-on delay
- ▶ t₂: Delay-on de-energisation

Wiring

Please note:

- ▶ Information given in the "Technical details" must be followed.
- ▶ Outputs 13-14, 23-24, 33-34, 43-44 are safety contacts, output 51-52 is an auxiliary contact (e.g. for display).
- ▶ To prevent contact welding, a fuse should be connected before the output contacts (see technical details).
- ▶ Calculation of the max. cable runs I_{max} in the input circuit:

$$I_{\max} = \frac{R_{I\max}}{R_l / \text{km}}$$

R_{I_{max}} = max. overall cable resistance (see technical details)

R_l /km = cable resistance/km

- ▶ Use copper wire that can withstand 60/75 °C.
- ▶ Sufficient fuse protection must be provided on all output contacts with capacitive and inductive loads.

Up to PL e of EN ISO 13849-1 PNOZ s10

Preparing for operation

► Supply voltage

Supply voltage	AC	DC

► Input circuit

Input circuit	Single-channel	Dual-channel
Base unit: Safety relay PNOZ X		
Base unit: Safety relay PNOZelog Driven via semiconductor outputs (24 VDC)		

► Feedback circuit

Feedback circuit	Base unit: Safety relay PNOZ X	Base unit: Safety relay PNOZelog
The inputs that evaluate the feedback loop will depend on the base unit and application		

► Connection to PNOZsigma base unit

	Base unit: Safety relay PNOZsigma
The feedback loop is connected and evaluated via the connector	

INFORMATION

If a base unit and a contact expander module from the PNOZsigma range are connected via the connector, no additional wiring is necessary.

Do not connect A1 to the contact expander module!

Up to PL e of EN ISO 13849-1 PNOZ s10

Terminal configuration

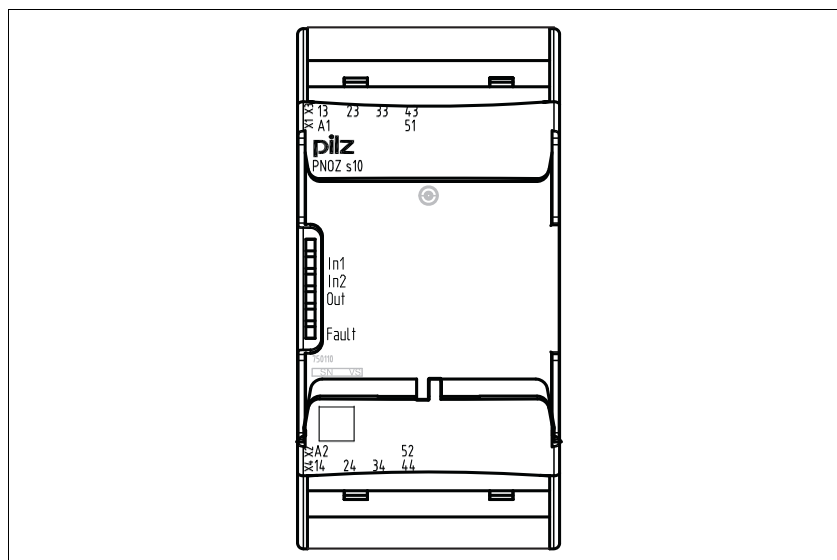

Installation

Install contact expander module without base unit:

- ▶ Ensure that the plug terminator is inserted at the side of the unit.

Connect base unit and PNOZsigma contact expander module:

- ▶ Remove the plug terminator at the side of the base unit and at the contact expander module
- ▶ Connect the base unit and the contact expander module to the supplied connector before mounting the units to the DIN rail.

Installation in control cabinet

- ▶ The safety relay should be installed in a control cabinet with a protection type of at least IP54.
- ▶ Use the notch on the rear of the unit to attach it to a DIN rail (35 mm).
- ▶ When installed vertically: Secure the unit by using a fixing element (e.g. retaining bracket or end angle).
- ▶ Push the unit upwards or downwards before lifting it from the DIN rail.

Dimensions

*with spring-loaded terminals

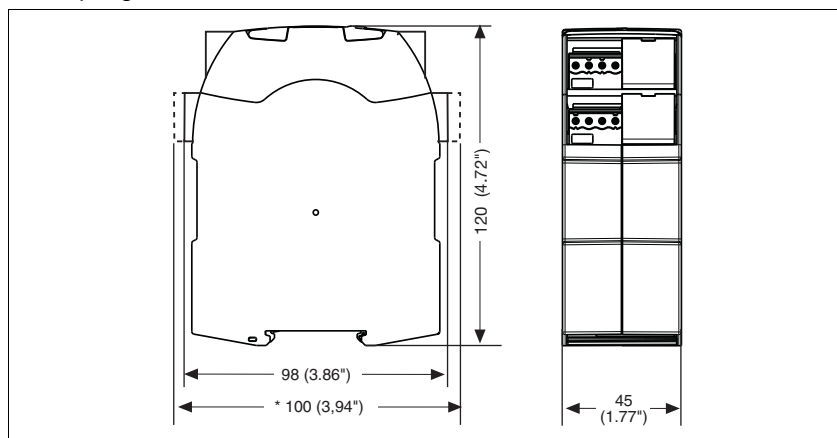

Up to PL e of EN ISO 13849-1 PNOZ s10

Notice

This data sheet is only intended for use during configuration. Please refer to the operating manual for installation and operation.

Service life graph

The service life graphs indicate the number of cycles from which failures due to wear must be expected. The wear is mainly caused by the electrical load; the mechanical load is negligible.

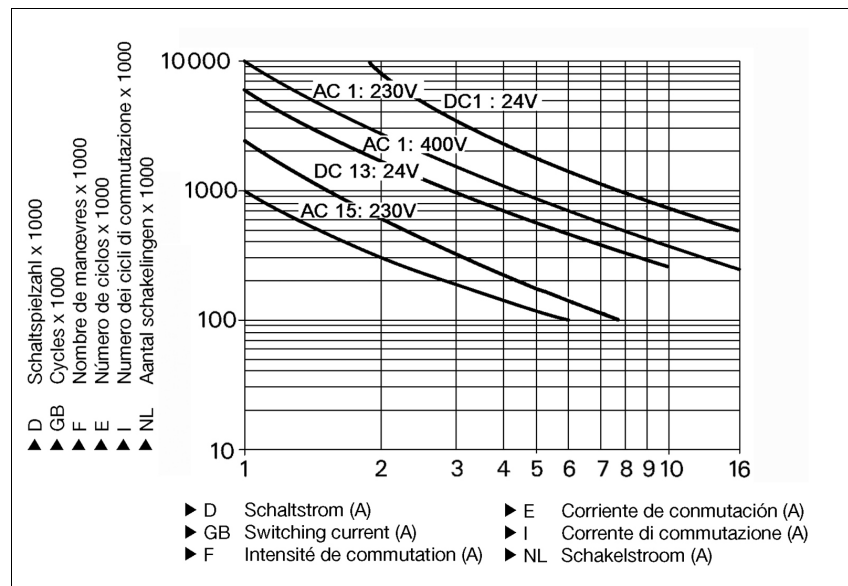

Example

- ▶ Inductive load: 2 A
 - ▶ Utilisation category: AC15
 - ▶ Contact service life: 300 000 cycles
- Provided the application requires fewer than 300 000 cycles, the PFH value (see technical details) can be used in the calculation.

To increase the service life, sufficient spark suppression must be provided on all output contacts. With capacitive loads, any power surges that occur must be noted. With contactors, use freewheel diodes for spark suppression.

Technical details

Electrical data

Supply voltage	
Supply voltage U_B DC	24 V
Voltage tolerance	-20 %/+20 %
Power consumption at U_B DC	3.0 W
Residual ripple DC	20 %
Voltage and current at	
Input circuit DC: 24.0 V	95.0 mA
Number of output contacts	
Safety contacts (S) instantaneous:	4
Auxiliary contacts (N/C):	1

Up to PL e of EN ISO 13849-1 PNOZ s10

Electrical data

Utilisation category in accordance with EN 60947-4-1	
Safety contacts: AC1 at 240 V	I_{\min} : 0.01 A , I_{\max} : 12.0 A P_{\max} : 3000 VA
Safety contacts: DC1 at 24 V	I_{\min} : 0.01 A , I_{\max} : 12.0 A P_{\max} : 300 W
Auxiliary contacts: AC1 at 240 V	I_{\min} : 0.01 A , I_{\max} : 2.0 A P_{\max} : 500 VA
Auxiliary contacts: DC1 at 24 V	I_{\min} : 0.01 A , I_{\max} : 2.0 A P_{\max} : 50 W
Utilisation category in accordance with EN 60947-5-1	
Safety contacts: AC15 at 230 V	I_{\max} : 6.0 A
Safety contacts: DC13 at 24 V (6 cycles/min)	I_{\max} : 7.5 A
Auxiliary contacts: AC15 at 230 V	I_{\max} : 2.0 A
Auxiliary contacts: DC13 at 24 V (6 cycles/min)	I_{\max} : 2.0 A

Contact material	AgSnO₂ + 0.2 µm Au
------------------	--------------------------------------

External contact fuse protection ($I_K = 1$ kA) to **EN 60947-5-1**

Blow-out fuse, quick	
Safety contacts:	16 A
Auxiliary contacts:	4 A
Blow-out fuse, slow	
Safety contacts:	10 A
Auxiliary contacts:	2 A
Circuit breaker 24 VAC/DC, characteristic B/C	
Safety contacts:	10 A
Auxiliary contacts:	2 A

Max. overall cable resistance R_{lmax} input circuits, reset circuits single-channel at U_B DC	30 Ohm
--	---------------

Safety-related characteristic data

PL in accordance with EN ISO 13849-1: 2006	PL e (Cat. 4)
Category in accordance with EN 954-1	Cat. 4
SIL CL in accordance with EN IEC 62061	SIL CL 3
PFH in accordance with EN IEC 62061	2.31E-09
SIL in accordance with IEC 61511	SIL 3
PFD in accordance with IEC 61511	2.03E-06
T_M [year] in accordance with EN ISO 13849-1: 2006	20

Times

Switch-on delay	
with automatic reset after power on typ.	30 ms
with automatic reset after power on max.	50 ms
Delay-on de-energisation	
with E-STOP typ.	20 ms
with E-STOP max.	30 ms
with power failure typ.	20 ms
with power failure max.	30 ms

Environmental data

EMC	EN 60947-5-1, EN 61000-6-2, EN 61000-6-4
Vibration to EN 60068-2-6	
Frequency	10 - 55 Hz
Amplitude	0.35 mm
Climatic suitability	EN 60068-2-78
Airgap creepage in accordance with EN 60947-1	
Pollution degree	2
Overvoltage category	III
Rated insulation voltage	250 V
Rated impulse withstand voltage	6.00 kV
Ambient temperature	-10 - 55 °C

Up to PL e of EN ISO 13849-1 PNOZ s10

Environmental data	
Storage temperature	-40 - 85 °C
Protection type	
Mounting (e.g. cabinet)	IP54
Housing	IP40
Terminals	IP20
Mechanical data	
Housing material	
Housing	PC
Front	PC
Cross section of external conductors with screw terminals	
1 core flexible	0.25 - 2.50 mm ² , 24 - 12 AWG No. 750110
2 core, same cross section, flexible:	
with crimp connectors, without insulating sleeve	0.25 - 1.00 mm ² , 24 - 16 AWG No. 750110
without crimp connectors or with TWIN crimp connectors	0.20 - 1.50 mm ² , 24 - 16 AWG No. 750110
Torque setting with screw terminals	0.50 Nm No. 750110
Cross section of external conductors with spring-loaded terminals: Flexible with/without crimp connectors	0.20 - 2.50 mm ² , 24 - 12 AWG No. 751110
Spring-loaded terminals: Terminal points per connection	2 No. 751110
Stripping length	9 mm No. 751110
Dimensions	
Height	98.0 mm
Width	45.0 mm
Depth	120.0 mm
Weight	300 g

No. stands for order number.

It is essential to consider the relay's service life graphs. The relay outputs' safety-related characteristic data is only valid if the values in the service life graphs are met.

The PFH value depends on the switching frequency and the load on the relay output.

If the service life graphs are not accessible, the stated PFH value can be

used irrespective of the switching frequency and the load, as the PFH value already considers the relay's B10d value as well as the failure rates of the other components.

All the units used within a safety function must be considered when calculating the safety characteristic data.

INFORMATION

A safety function's SIL/PL values are **not** identical to the SIL/PL values of the units that are used and may be different. We recommend that you use the PAScal software tool to calculate the safety function's SIL/PL values.

The standards current on **2006-04** apply.

Conventional thermal current while loading several contacts	
Number of contacts	I_{th} per contact at U_B DC
1	12.00 A
2	11.00 A
3	9.00 A
4	8.00 A

Up to PL e of EN ISO 13849-1 PNOZ s10

Order reference

Type	Features	Terminals	Order no.
PNOZ s10	24 VDC	With screw terminal	750 110
PNOZ s10 C	24 VDC	With spring-loaded terminal	751 110