

74HC594; 74HCT594

8-bit shift register with output register

Product data sheet

1. General description

The 74HC594; 74HCT594 is a high-speed Si-gate CMOS device and is pin compatible with Low-Power Schottky TTL (LSTTL).

The 74HC594; 74HCT594 is an 8-bit, non-inverting, serial-in, parallel-out shift register that feeds an 8-bit D-type storage register. Separate clocks (SHCP and STCP) and direct overriding clears (SHR and STR) are provided on both the shift and storage registers. A serial output (Q7S) is provided for cascading purposes.

Both the shift and storage register clocks are positive-edge triggered. If the user wishes to connect both clocks together, the shift register will always be one count pulse ahead of the storage register.

2. Features

- Synchronous serial input and output
- Complies with JEDEC standard No.7A
- 8-bit parallel output
- Shift and storage registers have independent direct clear and clocks
- Independent clocks for shift and storage registers
- 100 MHz (typical)
- Multiple package options
- Specified from $-40\text{ }^{\circ}\text{C}$ to $+85\text{ }^{\circ}\text{C}$ and from $-40\text{ }^{\circ}\text{C}$ to $+125\text{ }^{\circ}\text{C}$

3. Applications

- Serial-to parallel data conversion
- Remote control holding register

4. Ordering information

Table 1. Ordering information

Type number	Package			Version
	Temperature range	Name	Description	
74HC594D	-40 °C to +125 °C	SO16	plastic small outline package; 16 leads; body width 3.9 mm	SOT109-1
74HC594DB	-40 °C to +125 °C	SSOP16	plastic shrink small outline package; 16 leads; body width 5.3 mm	SOT338-1
74HC594N	-40 °C to +125 °C	DIP16	plastic dual in-line package; 16 leads (300 mil)	SOT38-4
74HCT594D	-40 °C to +125 °C	SO16	plastic small outline package; 16 leads; body width 3.9 mm	SOT109-1
74HCT594DB	-40 °C to +125 °C	SSOP16	plastic shrink small outline package; 16 leads; body width 5.3 mm	SOT338-1
74HCT594N	-40 °C to +125 °C	DIP16	plastic dual in-line package; 16 leads (300 mil)	SOT38-4

5. Functional diagram

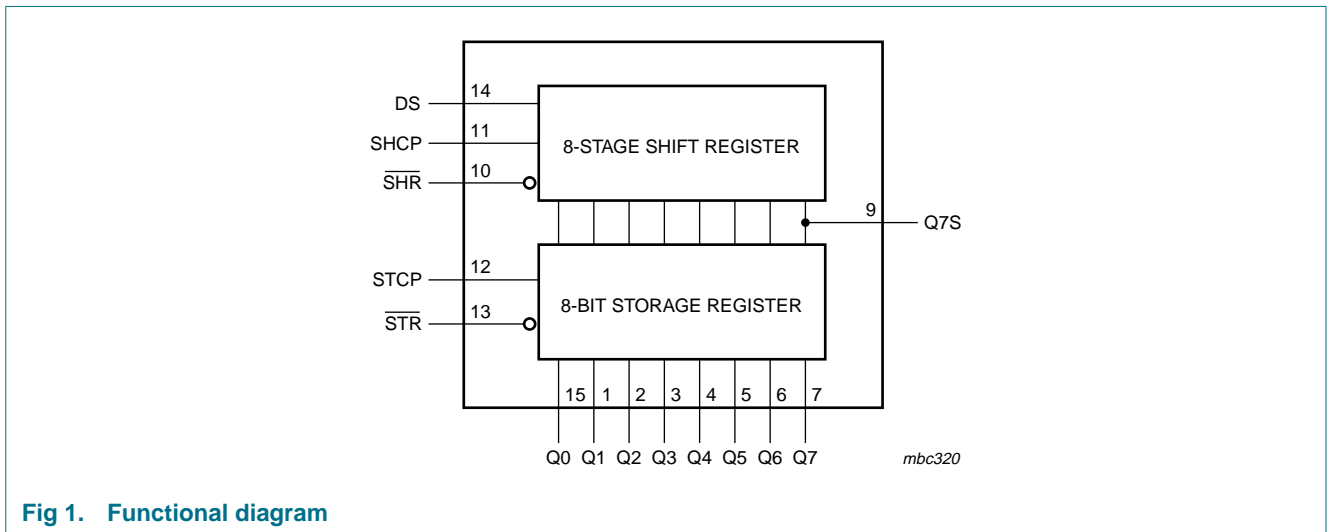

Fig 1. Functional diagram

7. Functional description

Table 3. Function table^[1]

Function	Input				
	SHR	STR	SHCP	STCP	DS
Clear shift register	L	X	X	X	X
Clear storage register	X	L	X	X	X
Load DS into shift register stage 0, advance previous stage data to the next stage	H	X	↑	X	H or L
Transfer shift register data to storage register and outputs Qn	X	H	X	↑	X
Shift register one count pulse ahead of storage register	H	H	↑	↑	X

- [1] H = HIGH voltage level;
 L = LOW voltage level;
 ↑ = LOW-to-HIGH transition;
 X = don't care.

8. Limiting values

Table 4. Limiting values

In accordance with the Absolute Maximum Rating System (IEC 60134). Voltages are referenced to GND (ground = 0 V).

Symbol	Parameter	Conditions	Min	Max	Unit
V _{CC}	supply voltage		-0.5	+7.0	V
I _{IK}	input clamping current	V _I < -0.5 V or V _I > V _{CC} + 0.5 V	[1] -	±20	mA
I _{OK}	output clamping current	V _O < -0.5 V or V _O > V _{CC} + 0.5 V	[1] -	±20	mA
I _O	output current	V _O = -0.5 V to V _{CC} + 0.5 V			
		Serial data output Q7S	-	±25	mA
		Parallel data output	-	±35	mA
I _{CC}	supply current	Serial data output Q7S	-	50	mA
		Parallel data output	-	70	mA
I _{GND}	ground current	Serial data output Q7S	-	-50	mA
		Parallel data output	-	-70	mA
T _{stg}	storage temperature		-65	+150	°C
P _{tot}	total power dissipation	T _{amb} = -40 °C to +125 °C	[2] -	500	mW

- [1] The input and output voltage ratings may be exceeded if the input and output current ratings are observed.
 [2] For DIP16 packages: above 70 °C the value of P_{tot} derates linearly with 12 mW/K.
 For SO16 packages: above 70 °C the value of P_{tot} derates linearly with 8 mW/K.
 For SSOP16 packages: above 60 °C the value of P_{tot} derates linearly with 5.5 mW/K.

9. Recommended operating conditions

Table 5. Recommended operating conditions

Symbol	Parameter	Conditions	Min	Typ	Max	Unit
Type 74HC594						
V_{CC}	supply voltage		2.0	5.0	6.0	V
V_I	input voltage		0	-	V_{CC}	V
V_O	output voltage		0	-	V_{CC}	V
T_{amb}	ambient temperature		-40	+25	+125	°C
t_r	rise time	$V_{CC} = 2.0\text{ V}$	-	-	1000	ns
		$V_{CC} = 4.5\text{ V}$	-	6.0	500	ns
		$V_{CC} = 6.0\text{ V}$	-	-	400	ns
t_f	fall time	$V_{CC} = 2.0\text{ V}$	-	-	1000	ns
		$V_{CC} = 4.5\text{ V}$	-	6.0	500	ns
		$V_{CC} = 6.0\text{ V}$	-	-	400	ns
Type 74HCT594						
V_{CC}	supply voltage		4.5	5.0	5.5	V
V_I	input voltage		0	-	V_{CC}	V
V_O	output voltage		0	-	V_{CC}	V
T_{amb}	ambient temperature		-40	+25	+125	°C
t_r	rise time	$V_{CC} = 4.5\text{ V}$	-	6.0	500	ns
t_f	fall time	$V_{CC} = 4.5\text{ V}$	-	6.0	500	ns

10. Static characteristics

Table 6. Static characteristics type 74HC594

At recommended operating conditions; voltages are referenced to GND (ground = 0 V).

Symbol	Parameter	Conditions	Min	Typ	Max	Unit
$T_{amb} = 25\text{ °C}$						
V_{IH}	HIGH-level input voltage	$V_{CC} = 2.0\text{ V}$	1.5	1.2	-	V
		$V_{CC} = 4.5\text{ V}$	3.15	2.4	-	V
		$V_{CC} = 6.0\text{ V}$	4.2	3.2	-	V
V_{IL}	LOW-level input voltage	$V_{CC} = 2.0\text{ V}$	-	0.8	0.5	V
		$V_{CC} = 4.5\text{ V}$	-	2.1	1.35	V
		$V_{CC} = 6.0\text{ V}$	-	2.8	1.8	V
V_{OH}	HIGH-level output voltage	$V_I = V_{IH}$ or V_{IL}				
Serial data output Q7S						
		$I_O = -4.0\text{ mA}; V_{CC} = 4.5\text{ V}$	3.98	4.32	-	V
		$I_O = -5.2\text{ mA}; V_{CC} = 6.0\text{ V}$	5.48	5.81	-	V
Parallel data outputs						
		$I_O = -6.0\text{ mA}; V_{CC} = 4.5\text{ V}$	3.98	4.32	-	V
		$I_O = -7.8\text{ mA}; V_{CC} = 6.0\text{ V}$	5.48	5.81	-	V

Table 6. Static characteristics type 74HC594 ...continued
 At recommended operating conditions; voltages are referenced to GND (ground = 0 V).

Symbol	Parameter	Conditions	Min	Typ	Max	Unit	
V _{OL}	LOW-level output voltage	V _I = V _{IH} or V _{IL}					
		Serial data output Q7S					
		I _O = 4.0 mA; V _{CC} = 4.5 V	-	0.15	0.26	V	
		I _O = 5.2 mA; V _{CC} = 6.0 V	-	0.16	0.26	V	
		Parallel data outputs					
		I _O = 6.0 mA; V _{CC} = 4.5 V	-	0.15	0.26	V	
		I _O = 7.8 mA; V _{CC} = 6.0 V	-	0.16	0.26	V	
I _I	input leakage current	V _I = V _{CC} or GND; V _{CC} = 6.0 V	-	-	±0.1	µA	
I _{CC}	supply current	V _I = V _{CC} or GND; I _O = 0 A; V _{CC} = 6.0 V	-	-	8.0	µA	
C _i	input capacitance		-	3.5	-	pF	
T_{amb} = -40 °C to +85 °C							
V _{IH}	HIGH-level input voltage	V _{CC} = 2.0 V	1.5	-	-	V	
		V _{CC} = 4.5 V	3.15	-	-	V	
		V _{CC} = 6.0 V	4.2	-	-	V	
V _{IL}	LOW-level input voltage	V _{CC} = 2.0 V	-	-	0.5	V	
		V _{CC} = 4.5 V	-	-	1.35	V	
		V _{CC} = 6.0 V	-	-	1.8	V	
V _{OH}	HIGH-level output voltage	V _I = V _{IH} or V _{IL}					
		Serial data output Q7S					
		I _O = -4.0 mA; V _{CC} = 4.5 V	3.84	-	-	V	
		I _O = -5.2 mA; V _{CC} = 6.0 V	5.34	-	-	V	
		Parallel data outputs					
		I _O = -6.0 mA; V _{CC} = 4.5 V	3.84	-	-	V	
		I _O = -7.8 mA; V _{CC} = 6.0 V	5.34	-	-	V	
V _{OL}	LOW-level output voltage	V _I = V _{IH} or V _{IL}					
		Serial data output Q7S					
		I _O = 4.0 mA; V _{CC} = 4.5 V	-	-	0.33	V	
		I _O = 5.2 mA; V _{CC} = 6.0 V	-	-	0.33	V	
		Parallel data outputs					
		I _O = 6.0 mA; V _{CC} = 4.5 V	-	-	0.33	V	
		I _O = 7.8 mA; V _{CC} = 6.0 V	-	-	0.33	V	
I _I	input leakage current	V _I = V _{CC} or GND; V _{CC} = 6.0 V	-	-	±1.0	µA	
I _{CC}	supply current	V _I = V _{CC} or GND; I _O = 0 A; V _{CC} = 6.0 V	-	-	80	µA	
T_{amb} = -40 °C to +125 °C							
V _{IH}	HIGH-level input voltage	V _{CC} = 2.0 V	1.5	-	-	V	
		V _{CC} = 4.5 V	3.15	-	-	V	
		V _{CC} = 6.0 V	4.2	-	-	V	

Table 6. Static characteristics type 74HC594 ...continued
 At recommended operating conditions; voltages are referenced to GND (ground = 0 V).

Symbol	Parameter	Conditions	Min	Typ	Max	Unit	
V _{IL}	LOW-level input voltage	V _{CC} = 2.0 V	-	-	0.5	V	
		V _{CC} = 4.5 V	-	-	1.35	V	
		V _{CC} = 6.0 V	-	-	1.8	V	
V _{OH}	HIGH-level output voltage	V _I = V _{IH} or V _{IL}					
		Serial data output Q7S					
		I _O = -4.0 mA; V _{CC} = 4.5 V	3.7	-	-	V	
		I _O = -5.2 mA; V _{CC} = 6.0 V	5.2	-	-	V	
		Parallel data outputs					
		I _O = -6.0 mA; V _{CC} = 4.5 V	3.7	-	-	V	
		I _O = -7.8 mA; V _{CC} = 6.0 V	5.2	-	-	V	
V _{OL}	LOW-level output voltage	V _I = V _{IH} or V _{IL}					
		Serial data output Q7S					
		I _O = 4.0 mA; V _{CC} = 4.5 V	-	-	0.4	V	
		I _O = 5.2 mA; V _{CC} = 6.0 V	-	-	0.4	V	
		Parallel data outputs					
		I _O = 6.0 mA; V _{CC} = 4.5 V	-	-	0.4	V	
I _I	input leakage current	V _I = V _{CC} or GND; V _{CC} = 6.0 V	-	-	±1.0	μA	
		I _{CC}	supply current	V _I = V _{CC} or GND; I _O = 0 A;	-	-	160
V _{CC} = 6.0 V							

11. Dynamic characteristics

Table 8. Dynamic characteristics type 74HC594

GND = 0 V; $t_r = t_f = 6$ ns; $C_L = 50$ pF; see Figure 15.

Symbol	Parameter	Conditions	25 °C			-40 °C to +85 °C		-40 °C to +125 °C		Unit
			Min	Typ	Max	Min	Max	Min	Max	
t _{pd}	propagation delay	SHCP to Q7S; see Figure 9 ^[1]								
		V _{CC} = 2.0 V	-	44	150	-	185	-	225	ns
		V _{CC} = 4.5 V	-	16	30	-	37	-	45	ns
		V _{CC} = 5.0 V; C _L = 15 pF	-	13	-	-	-	-	-	ns
		V _{CC} = 6.0 V	-	14	26	-	31	-	38	ns
		STCP to Qn; see Figure 10								
		V _{CC} = 2.0 V	-	44	150	-	185	-	225	ns
		V _{CC} = 4.5 V	-	16	30	-	37	-	45	ns
		V _{CC} = 5.0 V; C _L = 15 pF	-	13	-	-	-	-	-	ns
		V _{CC} = 6.0 V	-	14	26	-	31	-	38	ns
t _{PHL}	HIGH to LOW propagation delay	SHR to Q7S; see Figure 13								
		V _{CC} = 2.0 V	-	39	150	-	185	-	225	ns
		V _{CC} = 4.5 V	-	14	30	-	37	-	45	ns
		V _{CC} = 5.0 V; C _L = 15 pF	-	11	-	-	-	-	-	ns
		V _{CC} = 6.0 V	-	12	26	-	31	-	38	ns
		STR to Qn; see Figure 14								
		V _{CC} = 2.0 V	-	39	125	-	155	-	185	ns
		V _{CC} = 4.5 V	-	14	25	-	31	-	37	ns
		V _{CC} = 5.0 V; C _L = 15 pF	-	11	-	-	-	-	-	ns
		V _{CC} = 6.0 V	-	12	21	-	26	-	31	ns
t _{THL}	HIGH to LOW output transition time	see Figure 9								
		Serial data output Q7S								
		V _{CC} = 2.0 V	-	19	75	-	95	-	110	ns
		V _{CC} = 4.5 V	-	7	15	-	19	-	22	ns
		V _{CC} = 6.0 V	-	6	13	-	16	-	19	ns
		Parallel data outputs								
		V _{CC} = 2.0 V	-	14	60	-	75	-	90	ns
		V _{CC} = 4.5 V	-	5	12	-	15	-	18	ns
		V _{CC} = 6.0 V	-	4	10	-	13	-	15	ns

Table 8. Dynamic characteristics type 74HC594 ...continued

$GND = 0\text{ V}$; $t_r = t_f = 6\text{ ns}$; $C_L = 50\text{ pF}$; see [Figure 15](#).

Symbol	Parameter	Conditions	25 °C			-40 °C to +85 °C		-40 °C to +125 °C		Unit
			Min	Typ	Max	Min	Max	Min	Max	
t_{TLH}	LOW to HIGH output transition time	see Figure 9								
		Serial data output Q7S								
		$V_{CC} = 2.0\text{ V}$	-	19	75	-	95	-	110	ns
		$V_{CC} = 4.5\text{ V}$	-	7	15	-	19	-	22	ns
		$V_{CC} = 6.0\text{ V}$	-	6	13	-	16	-	19	ns
		Parallel data outputs								
		$V_{CC} = 2.0\text{ V}$	-	14	60	-	75	-	90	ns
		$V_{CC} = 4.5\text{ V}$	-	5	12	-	15	-	18	ns
		$V_{CC} = 6.0\text{ V}$	-	4	10	-	13	-	15	ns
		t_w	pulse width	SHCP (HIGH or LOW); see Figure 9						
$V_{CC} = 2.0\text{ V}$	80			10	-	100	-	120	-	ns
$V_{CC} = 4.5\text{ V}$	16			4	-	20	-	24	-	ns
$V_{CC} = 6.0\text{ V}$	14			3	-	17	-	20	-	ns
STCP (HIGH or LOW); see Figure 10										
$V_{CC} = 2.0\text{ V}$	80			10	-	100	-	120	-	ns
$V_{CC} = 4.5\text{ V}$	16			4	-	20	-	24	-	ns
$V_{CC} = 6.0\text{ V}$	14			3	-	17	-	20	-	ns
SHR and STR (HIGH or LOW); see Figure 13 and Figure 14										
$V_{CC} = 2.0\text{ V}$	80			14	-	100	-	120	-	ns
$V_{CC} = 4.5\text{ V}$	16			5	-	20	-	24	-	ns
$V_{CC} = 6.0\text{ V}$	14			4	-	17	-	20	-	ns

Table 8. Dynamic characteristics type 74HC594 ...continued

$GND = 0\text{ V}$; $t_r = t_f = 6\text{ ns}$; $C_L = 50\text{ pF}$; see [Figure 15](#).

Symbol	Parameter	Conditions	25 °C			-40 °C to +85 °C		-40 °C to +125 °C		Unit
			Min	Typ	Max	Min	Max	Min	Max	
t_{su}	set-up time	DS to SHCP; see Figure 11								
		$V_{CC} = 2.0\text{ V}$	100	10	-	125	-	150	-	ns
		$V_{CC} = 4.5\text{ V}$	20	4	-	25	-	30	-	ns
		$V_{CC} = 6.0\text{ V}$	17	3	-	21	-	26	-	ns
		SHR to STCP; see Figure 12								
		$V_{CC} = 2.0\text{ V}$	100	14	-	125	-	150	-	ns
		$V_{CC} = 4.5\text{ V}$	20	5	-	25	-	30	-	ns
		$V_{CC} = 6.0\text{ V}$	17	4	-	21	-	26	-	ns
		SHCP to STCP; see Figure 10								
		$V_{CC} = 2.0\text{ V}$	100	17	-	125	-	150	-	ns
		$V_{CC} = 4.5\text{ V}$	20	6	-	25	-	30	-	ns
		$V_{CC} = 6.0\text{ V}$	17	5	-	21	-	26	-	ns
t_h	hold time	DS to SHCP; see Figure 11								
		$V_{CC} = 2.0\text{ V}$	25	-8	-	30	-	35	-	ns
		$V_{CC} = 4.5\text{ V}$	5	-3	-	6	-	7	-	ns
		$V_{CC} = 6.0\text{ V}$	4	-2	-	5	-	6	-	ns
t_{rec}	recovery time	SHR to SHCP and STR to STCP; see Figure 13 and Figure 14								
		$V_{CC} = 2.0\text{ V}$	50	-14	-	65	-	75	-	ns
		$V_{CC} = 4.5\text{ V}$	10	-5	-	13	-	15	-	ns
		$V_{CC} = 6.0\text{ V}$	9	-4	-	11	-	13	-	ns
f_{max}	maximum frequency	SHCP or STCP; see Figure 9 and Figure 10								
		$V_{CC} = 2.0\text{ V}$	6.0	30	-	4.8	-	4.0	-	MHz
		$V_{CC} = 4.5\text{ V}$	30	92	-	24	-	20	-	MHz
		$V_{CC} = 5.0\text{ V}$; $C_L = 15\text{ pF}$	-	100	-	-	-	-	-	MHz
		$V_{CC} = 6.0\text{ V}$	35	109	-	28	-	24	-	MHz

Table 8. Dynamic characteristics type 74HC594 ...continued

$GND = 0 V$; $t_r = t_f = 6 ns$; $C_L = 50 pF$; see [Figure 15](#).

Symbol	Parameter	Conditions	25 °C			-40 °C to +85 °C		-40 °C to +125 °C		Unit
			Min	Typ	Max	Min	Max	Min	Max	
C_{PD}	power dissipation capacitance	$V_I = GND$ to V_{CC} ; [2] $V_{CC} = 5 V$; $f_i = 1 MHz$	-	84	-	-	-	-	-	pF

[1] t_{pd} is the same as t_{PHL} and t_{PLH} .

[2] C_{PD} is used to determine the dynamic power dissipation (P_D in μW):

$$P_D = C_{PD} \times V_{CC}^2 \times f_i \times N + \sum(C_L \times V_{CC}^2 \times f_o) \text{ where:}$$

f_i = input frequency in MHz;

f_o = output frequency in MHz;

C_L = output load capacitance in pF;

V_{CC} = supply voltage in V;

N = number of inputs switching;

$\sum(C_L \times V_{CC}^2 \times f_o)$ = sum of outputs.

Table 9. Dynamic characteristics type 74HCT594

$GND = 0 V$; $V_{CC} = 4.5 V$; $t_r = t_f = 6 ns$; $C_L = 50 pF$; see [Figure 15](#).

Symbol	Parameter	Conditions	25 °C			-40 °C to +85 °C		-40 °C to +125 °C		Unit
			Min	Typ	Max	Min	Max	Min	Max	
t_{pd}	propagation delay	SHCP to Q7S; [1] see Figure 9	-	18	32	-	40	-	48	ns
		$V_{CC} = 5.0 V$; $C_L = 15 pF$	-	15	-	-	-	-	-	ns
		STCP to Qn; see Figure 10	-	18	32	-	40	-	48	ns
		$V_{CC} = 5.0 V$; $C_L = 15 pF$	-	15	-	-	-	-	-	ns
t_{PHL}	HIGH to LOW propagation delay	SHR to Q7S; see Figure 13	-	17	30	-	38	-	45	ns
		$V_{CC} = 5.0 V$; $C_L = 15 pF$	-	14	-	-	-	-	-	ns
		STR to Qn; see Figure 14	-	17	30	-	38	-	45	ns
		$V_{CC} = 5.0 V$; $C_L = 15 pF$	-	14	-	-	-	-	-	ns
t_{THL}	HIGH to LOW output transition time	see Figure 9 Serial data output Q7S								
		$V_{CC} = 4.5 V$	-	7	15	-	19	-	22	ns
		Parallel data outputs								
		$V_{CC} = 4.5 V$	-	5	12	-	15	-	18	ns
t_{TLH}	LOW to HIGH output transition time	see Figure 9 Serial data output Q7S								
		$V_{CC} = 4.5 V$	-	7	15	-	19	-	22	ns
		Parallel data outputs								
		$V_{CC} = 4.5 V$	-	5	12	-	15	-	18	ns

13. Package outline

SO16: plastic small outline package; 16 leads; body width 3.9 mm

SOT109-1

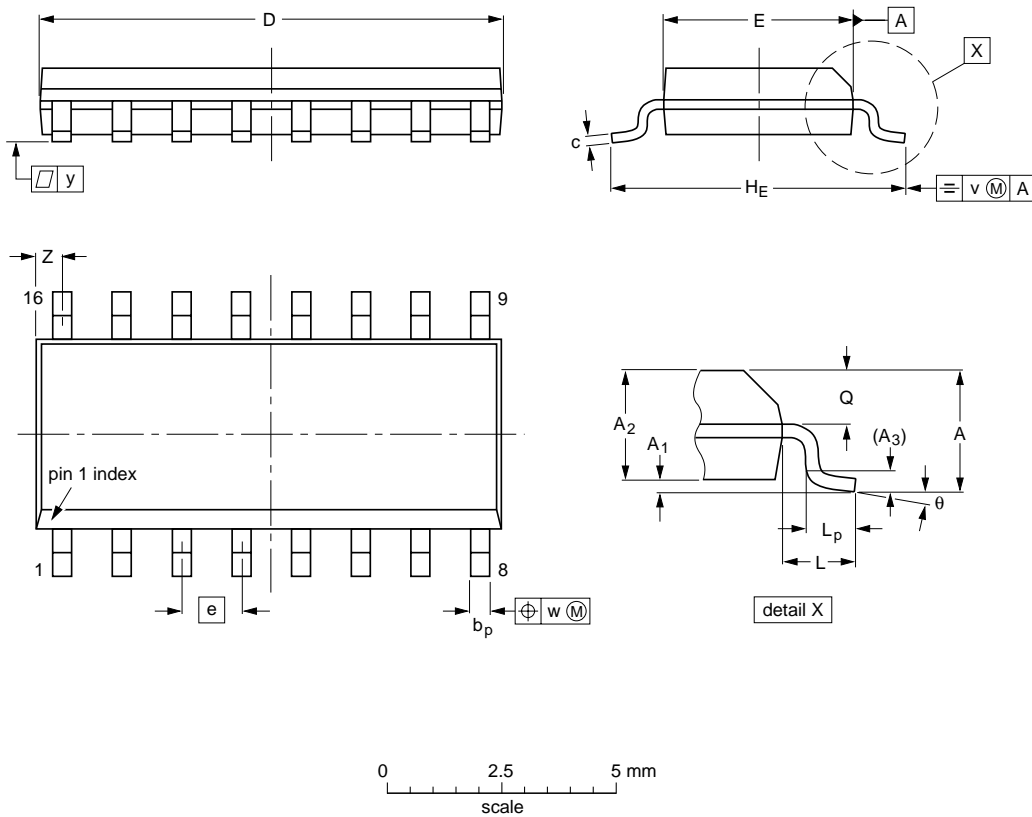

DIMENSIONS (inch dimensions are derived from the original mm dimensions)

UNIT	A max.	A ₁	A ₂	A ₃	b _p	c	D ⁽¹⁾	E ⁽¹⁾	e	H _E	L	L _p	Q	v	w	y	z ⁽¹⁾	θ
mm	1.75	0.25 0.10	1.45 1.25	0.25	0.49 0.36	0.25 0.19	10.0 9.8	4.0 3.8	1.27	6.2 5.8	1.05	1.0 0.4	0.7 0.6	0.25	0.25	0.1	0.7 0.3	8° 0°
inches	0.069	0.010 0.004	0.057 0.049	0.01	0.019 0.014	0.0100 0.0075	0.39 0.38	0.16 0.15	0.05	0.244 0.228	0.041	0.039 0.016	0.028 0.020	0.01	0.01	0.004	0.028 0.012	

Note

1. Plastic or metal protrusions of 0.15 mm (0.006 inch) maximum per side are not included.

OUTLINE VERSION	REFERENCES			EUROPEAN PROJECTION
	IEC	JEDEC	JEITA	
SOT109-1	076E07	MS-012		

Fig 16. Package outline SOT109-1 (SO16)