

MATERIALS AND FINISHES

BODY BRASS
PLATED SEE TABLE

CENTER CONTACT BERYLLIUM COPPER
PLATED SEE TABLE

PCB CONTACT BRASS
PLATED SEE TABLE

INSULATOR TEFLON

NOTES:

- 1. EXCEPTION TO PRODUCT SPECIFICATION
FREQUENCY RANGE: DC TO 12GHz

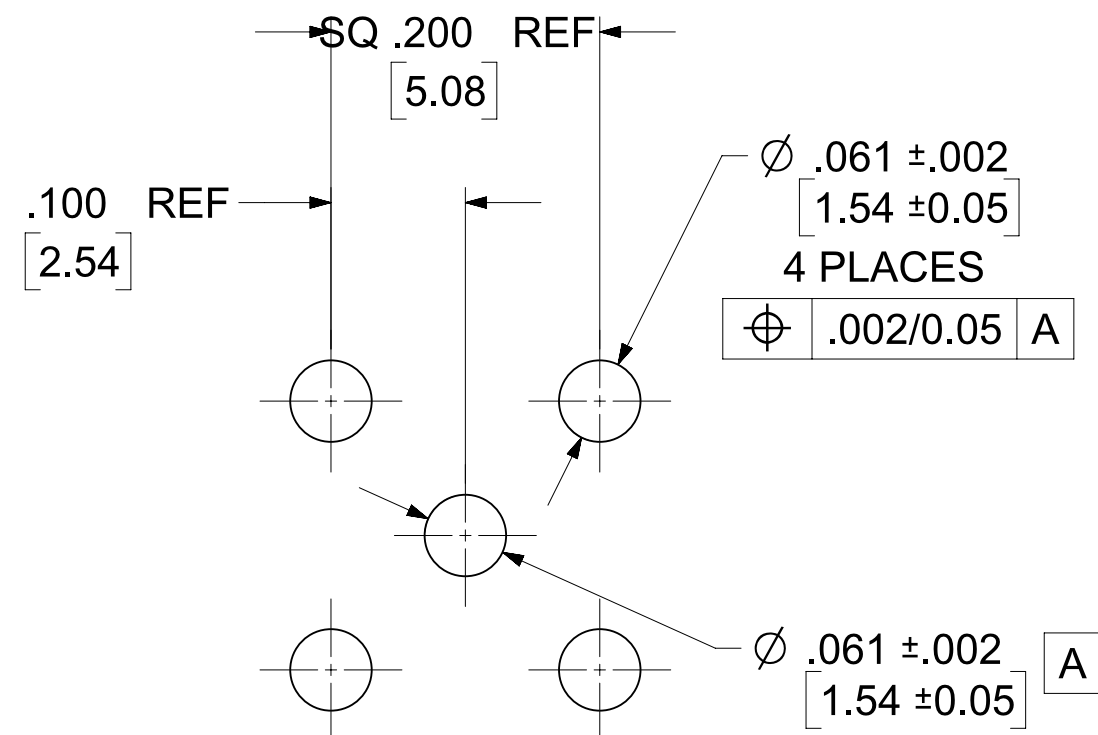

RECOMMENDED MOUNTING HOLE

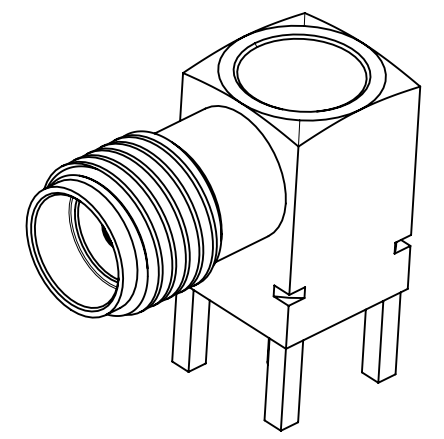
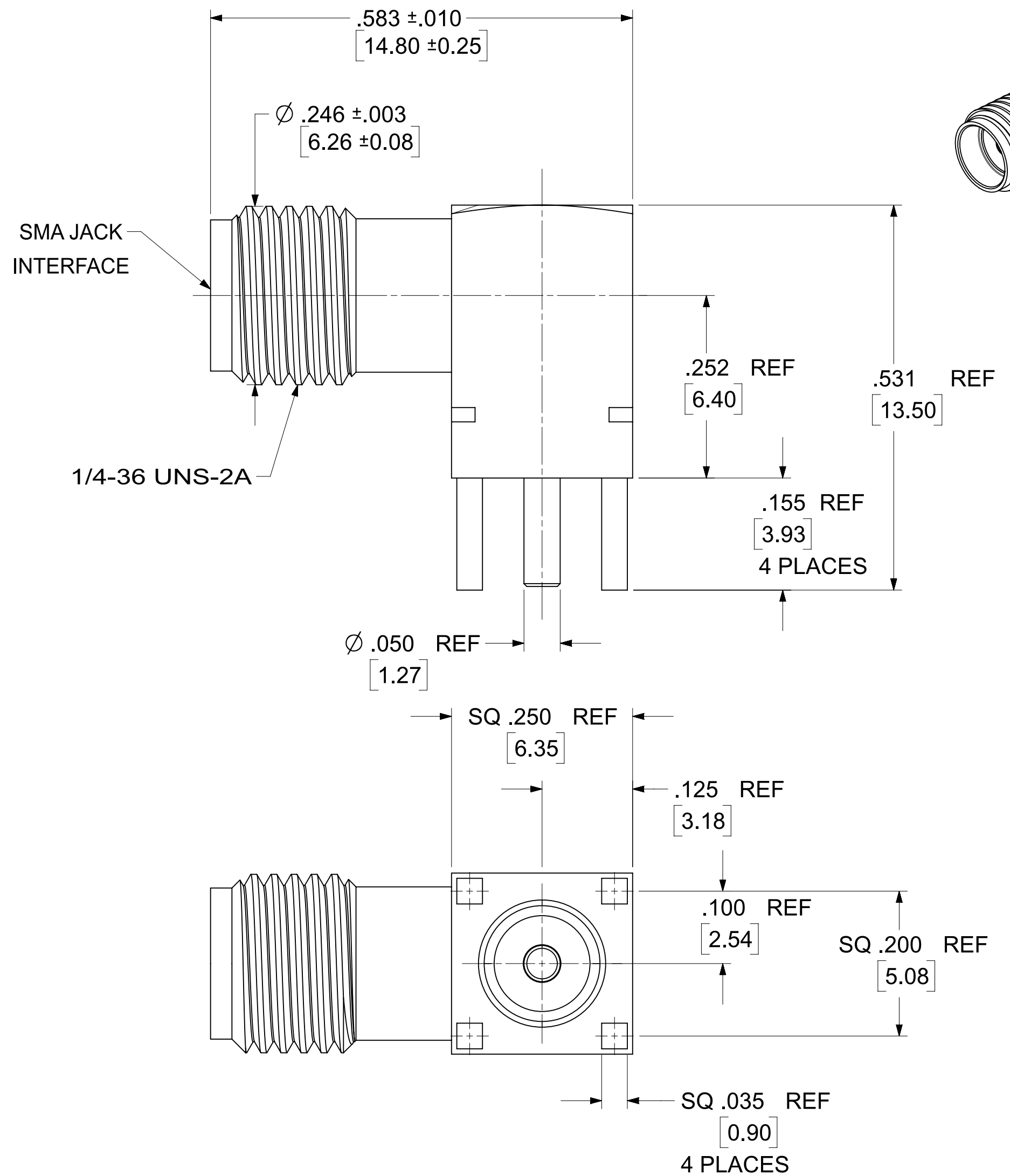

73251-7430	GOLD 10u"	GOLD 10u"	GOLD 10u"	73100-0114, TAPE & REEL, SEE PSD732517430	1000 PCS
73251-3132	GOLD FLASH	GOLD FLASH	GOLD FLASH	TRAY (80 CAVITY)	1760 PCS
73251-3130	GOLD 10u"	GOLD 10u"	GOLD 10u"	P/N: 73100-0114 PLACES IN A SINGLE BAG	1000 PCS
73100-0114	GOLD 10u"	GOLD 10u"	GOLD 10u"	TRAY (80 CAVITY)	3520 PCS
PART NO.	BODY PLATING	CENTER CONTACT PLATING	PCB CONTACT PLATING	PACKAGING TYPE	PACKAGING Q'TY IN CARTON (DU/MLQ)

PS-89675-368	SOLDER PROFILE SPEC.
PS-89675-3460	PRODUCT SPECIFICATION
SPECIFICATION	DESCRIPTION

FUNCTIONAL SYMBOLS $\overline{A} = 0$ $\overline{E} = 0$ $\overline{P} = 0$ DIVISIONAL SYMBOLS 4 PLACES ± 3 PLACES ± 2 PLACES ± 1 PLACE ± 0 PLACES ±	THIS DRAWING CONTAINS INFORMATION THAT IS PROPRIETARY TO MOLEX ELECTRONIC TECHNOLOGIES, LLC AND SHOULD NOT BE USED WITHOUT WRITTEN PERMISSION DIMENSION UNITS: INCH/MM SCALE: NTS CURRENT REV DESC: EWR-15712-A: ADDED 73251-3132 PART NO, ADDED SOLDER PROFILE SPEC, UPDATE PRODUCT SPEC TO PS-89675-3460 EWR-14120-B: ADDED 73251-7430 ON TABLE	<p>SMA JACK, R/A PCB, 50 OHMS SMA-J/PCB</p> <p>PRODUCT CUSTOMER DRAWING</p> <p>DOCUMENT NUMBER: SD-73100-0114 DOC TYPE: PSD DOC PART: 001 REVISION: D2</p> <p>STATUS: Production DRWN: Cela Wei CHK'D: Darry Cheng APPR: Darry Cheng</p> <p>2024-10-23 2025-02-25 2025-02-25</p> <p>DRAFT WHERE APPLICABLE MUST REMAIN WITHIN DIMENSIONS</p> <p>THIRD ANGLE PROJECTION</p> <p>DRAWING: C-SIZE SERIES: 73100</p> <p>MATERIAL NUMBER: GENERAL MARKET CUSTOMER: GENERAL MARKET SHEET NUMBER: 1 OF 4</p>
	GENERAL TOLERANCES (UNLESS SPECIFIED) ANGULAR TOL ± 2°	
	STATUS: Production DRWN: Cela Wei CHK'D: Darry Cheng APPR: Darry Cheng	
	DRAFT WHERE APPLICABLE MUST REMAIN WITHIN DIMENSIONS	

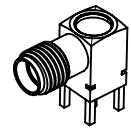

P/N: 73100-0114

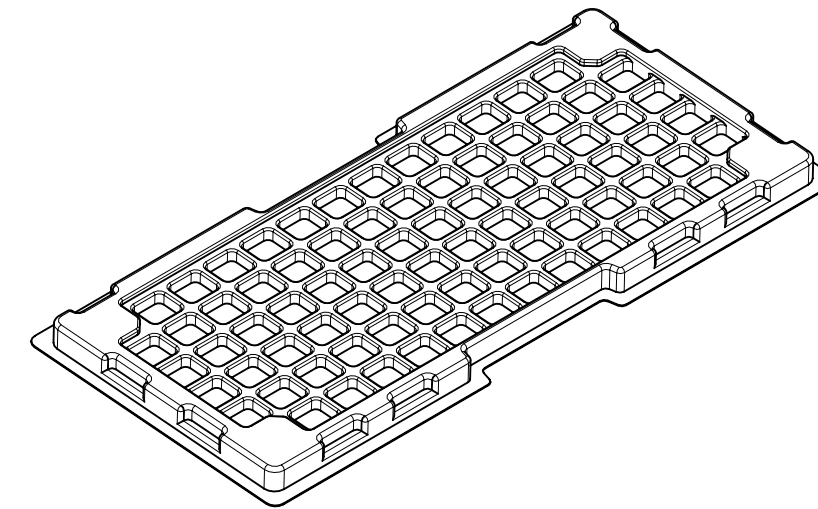
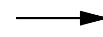

80 SETS PER TRAY
P/N: 89707-0190

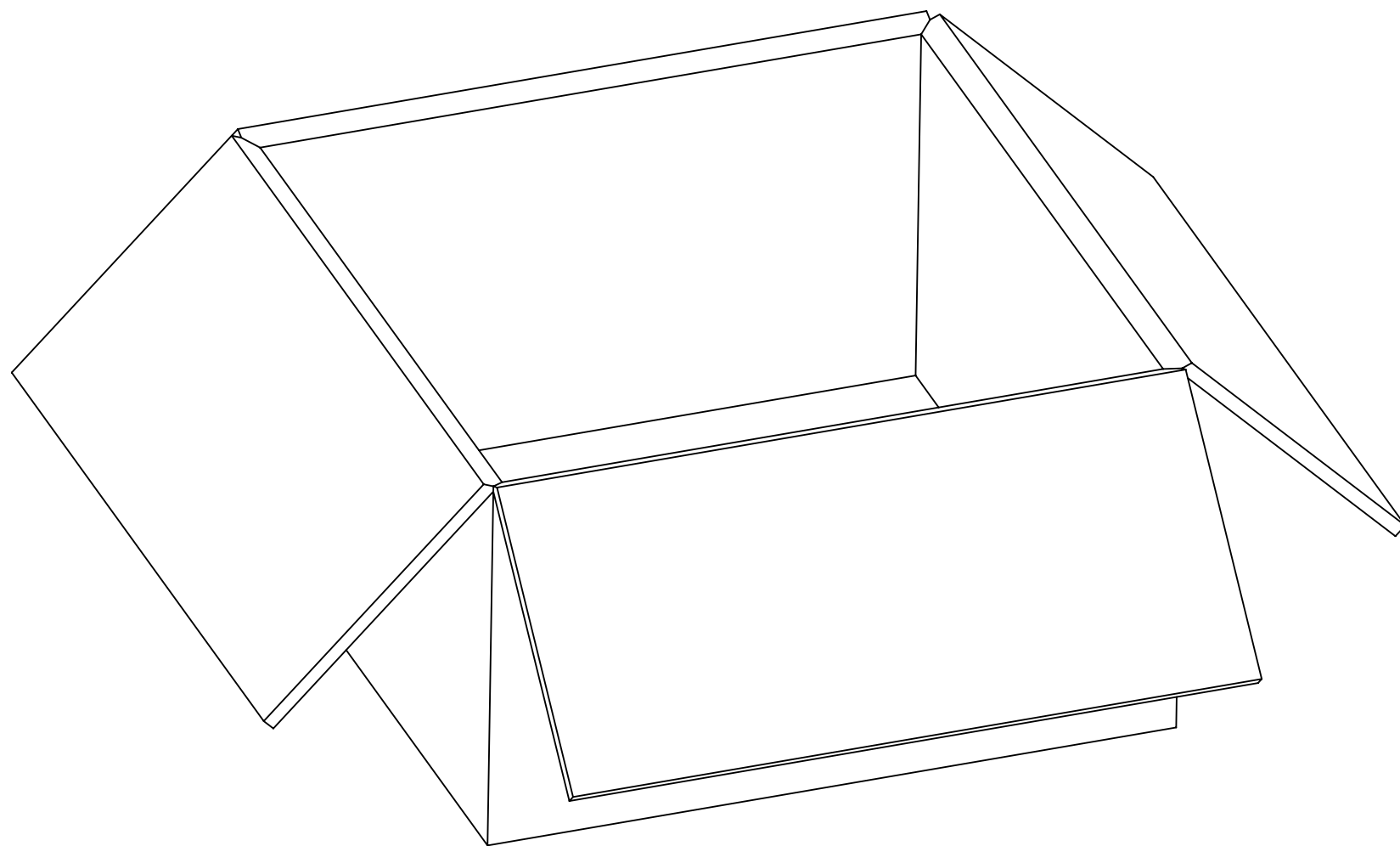

3520 SETS PER OUTER
CARTON BOX
P/N: 96708-0005

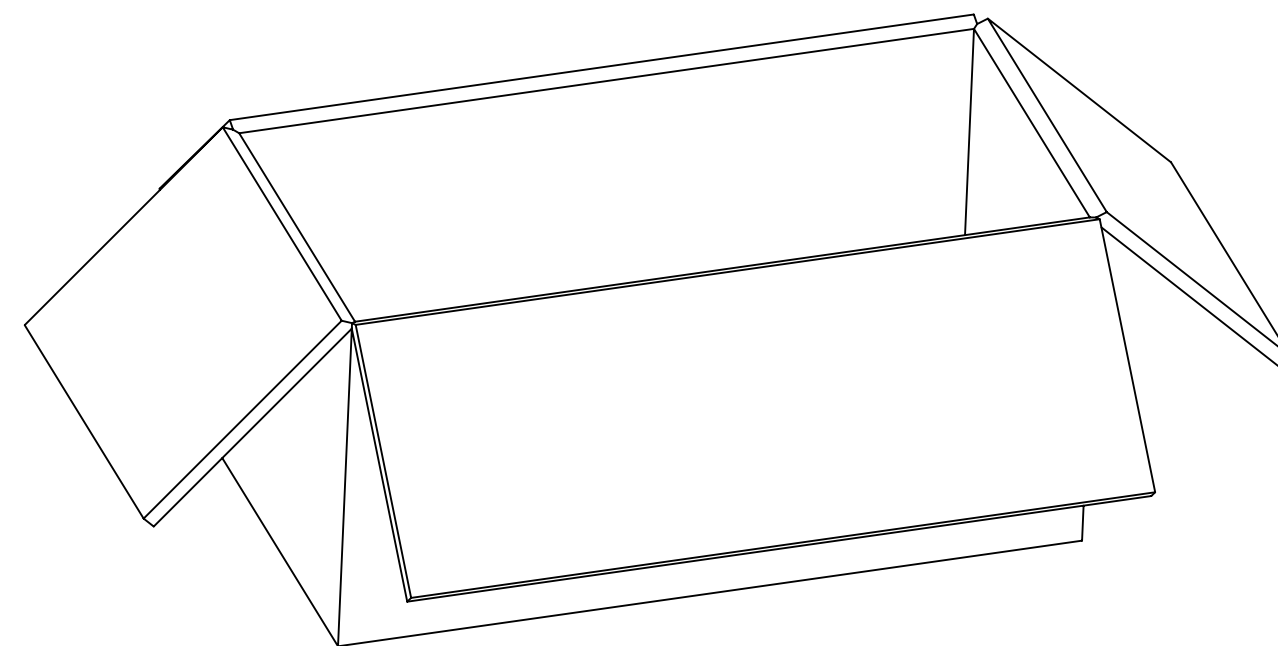

1760 SETS PER INNER
CARTON BOX
P/N: 96707-0001

FUNCTIONAL SYMBOLS = 0 = 0 = 0 DIVISIONAL SYMBOLS 3 PLACES ± 2 PLACES ± 1 PLACE ± 0 PLACES ±	THIS DRAWING CONTAINS INFORMATION THAT IS PROPRIETARY TO MOLEX ELECTRONIC TECHNOLOGIES, LLC AND SHOULD NOT BE USED WITHOUT WRITTEN PERMISSION		CURRENT REV DESC: EWR-15712-A: ADDED 73251-3132 PART NO, ADDED SOLDER PROFILE SPEC, UPDATE PRODUCT SPEC TO PS-89675-3460 EWR-14120-B: ADDED 73251-7430 ON TABLE					
	DIMENSION UNITS	SCALE	molex SMA JACK,R/A PCB,50 OHMS SMA-J/PCB PRODUCT CUSTOMER DRAWING					
	INCH/MM	NTS						
	GENERAL TOLERANCES (UNLESS SPECIFIED)							
ANGULAR TOL ± 2'		STATUS: Production						
4 PLACES ±		DRWN: Cela Wei	2024-10-23	DOCUMENT NUMBER	DOC TYPE	DOC PART	REVISION	
3 PLACES ±		CHK'D: Darry Cheng	2025-02-25	SD-73100-0114		PSD	001	D2
2 PLACES ±		APPR: Darry Cheng	2025-02-25	MATERIAL NUMBER		CUSTOMER		SHEET NUMBER
1 PLACE ±		THIRD ANGLE PROJECTION		DRAWING		SERIES		GENERAL MARKET
0 PLACES ±		DRAFT WHERE APPLICABLE MUST REMAIN WITHIN DIMENSIONS		C-SIZE		73100		2 OF 4

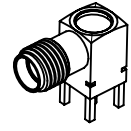

P/N: 73251-3132

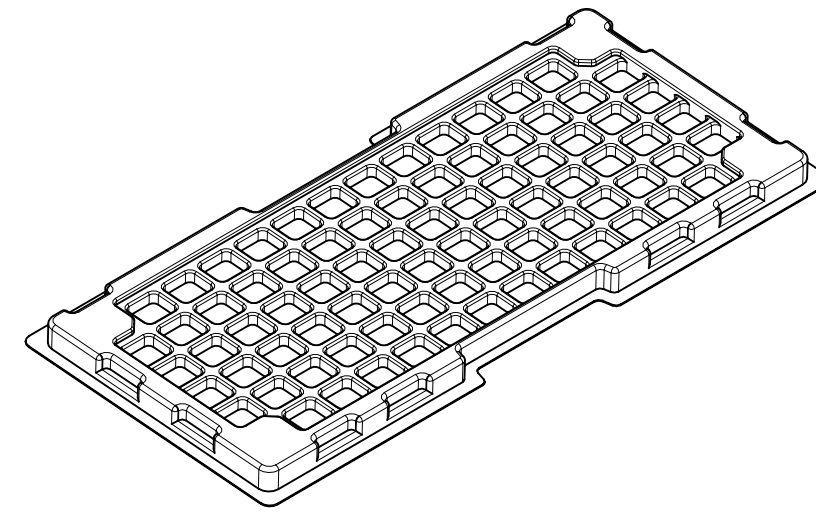
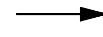

80 SETS PER TRAY

P/N: 89707-0190

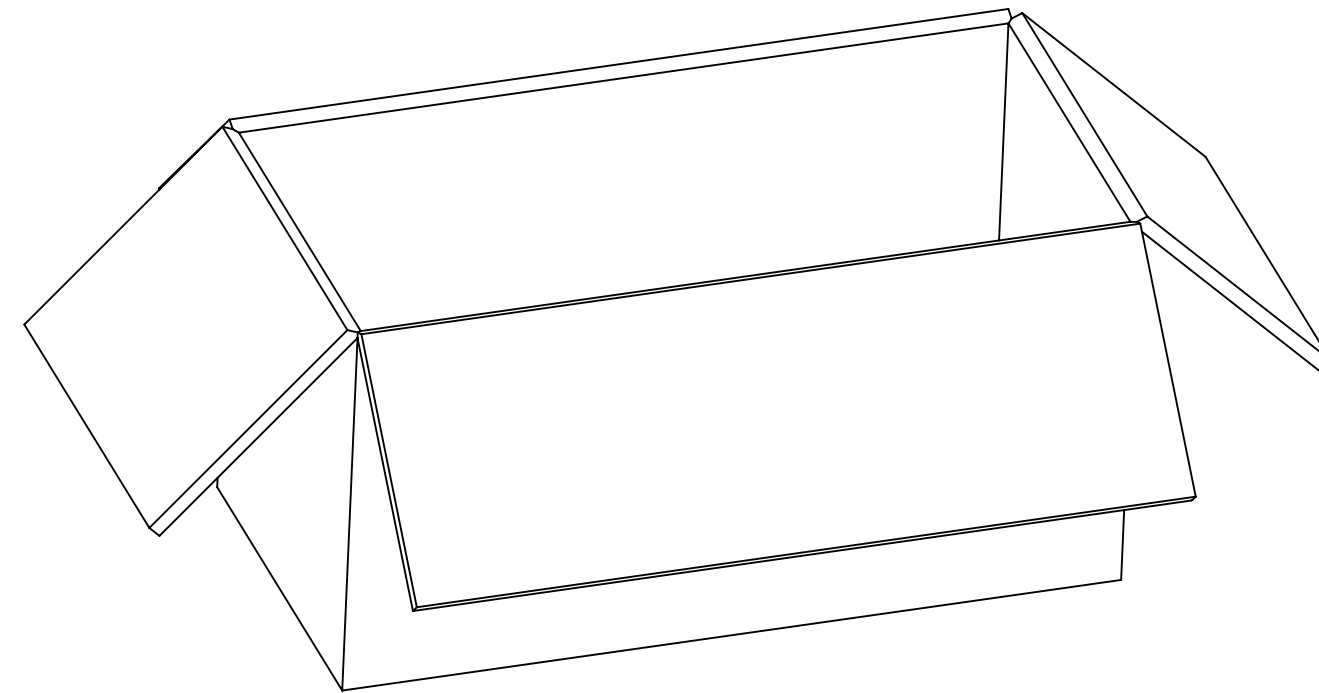

1760 SETS PER INNER

CARTON BOX

P/N: 96707-0002

FUNCTIONAL SYMBOLS	THIS DRAWING CONTAINS INFORMATION THAT IS PROPRIETARY TO MOLEX ELECTRONIC TECHNOLOGIES, LLC AND SHOULD NOT BE USED WITHOUT WRITTEN PERMISSION									
	DIMENSION UNITS	SCALE	CURRENT REV DESC: EWR-15712-A: ADDED 73251-3132 PART NO, ADDED SOLDER PROFILE SPEC, UPDATE PRODUCT SPEC TO PS-89675-3460 EWR-14120-B: ADDED 73251-7430 ON TABLE							
$\nabla_A = 0$	INCH/MM	NTS	<p>STATUS: Production</p> <p>DRWN: Cela Wei 2024-10-23</p> <p>CHK'D: Darry Cheng 2025-02-25</p> <p>APPR: Darry Cheng 2025-02-25</p>							
$\nabla_C = 0$	GENERAL TOLERANCES (UNLESS SPECIFIED)									
$\nabla_P = 0$	ANGULAR TOL	± 2'								
DIVISIONAL SYMBOLS	4 PLACES	±								
	3 PLACES	±	<p>2024-10-23</p> <p>2025-02-25</p> <p>2025-02-25</p>							
	2 PLACES	±								
	1 PLACE	±								
	0 PLACES	±								
	DRAFT WHERE APPLICABLE MUST REMAIN WITHIN DIMENSIONS	THIRD ANGLE PROJECTION	DRAWING	SERIES	MATERIAL NUMBER	CUSTOMER	SHEET NUMBER		REVISION	
			C-SIZE	73100		GENERAL MARKET	4 OF 4		SD-73100-0114	PSD 001 D2

molex

SMA JACK, R/A PCB, 50 OHMS
SMA-J/PCB

PRODUCT CUSTOMER DRAWING

DOCUMENT NUMBER DOC TYPE DOC PART REVISION

SD-73100-0114 PSD 001 D2

MATERIAL NUMBER CUSTOMER SHEET NUMBER

GENERAL MARKET 4 OF 4