

ANGLE 1

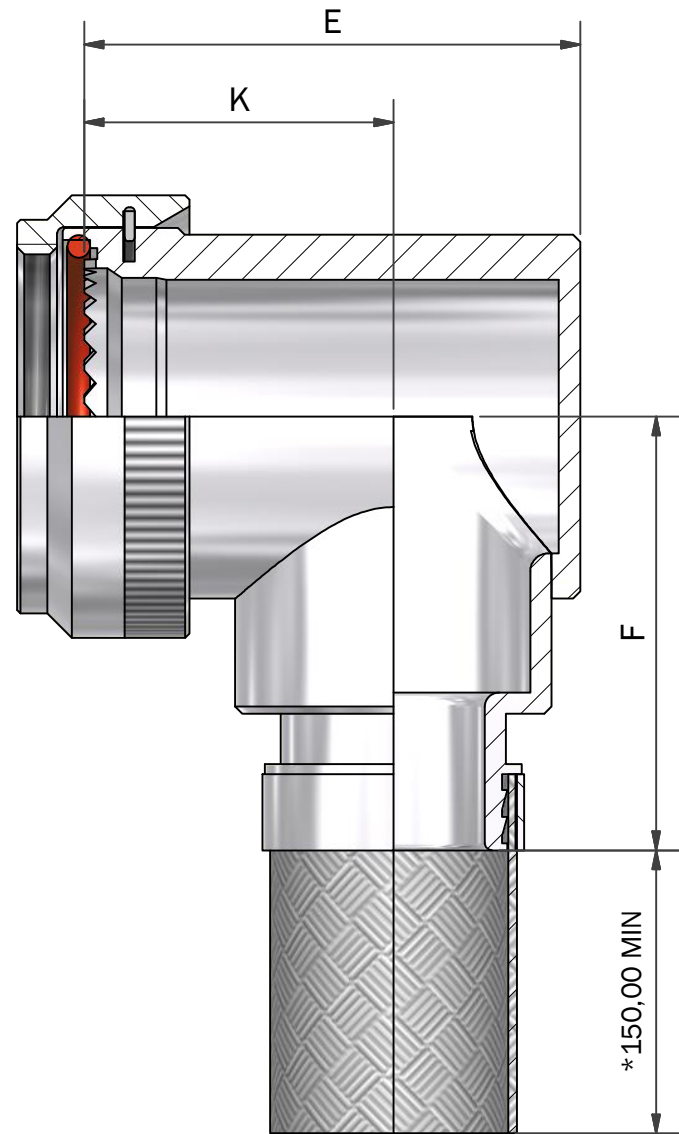

\*NOTE:  
 SUPPLIED WITH STANDARD BRAID TAIL LENGTH OF 150MM  
 CONTACT SALES OFFICE FOR NON-STANDARD BRAID TAIL LENGTHS

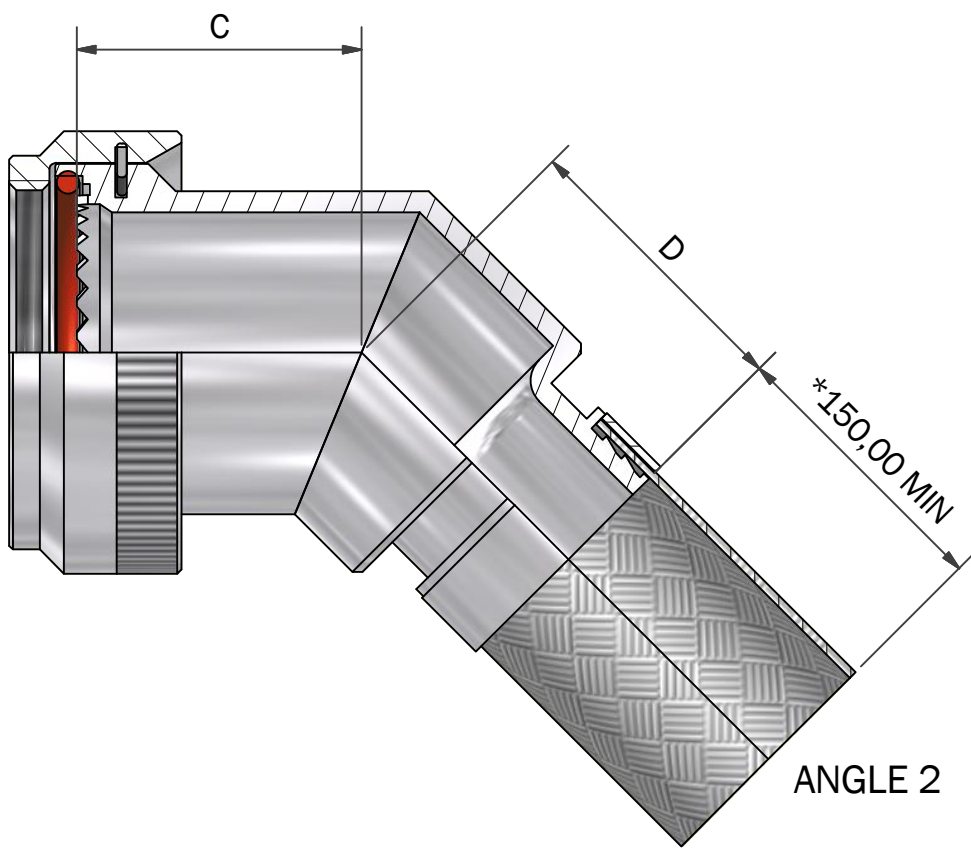
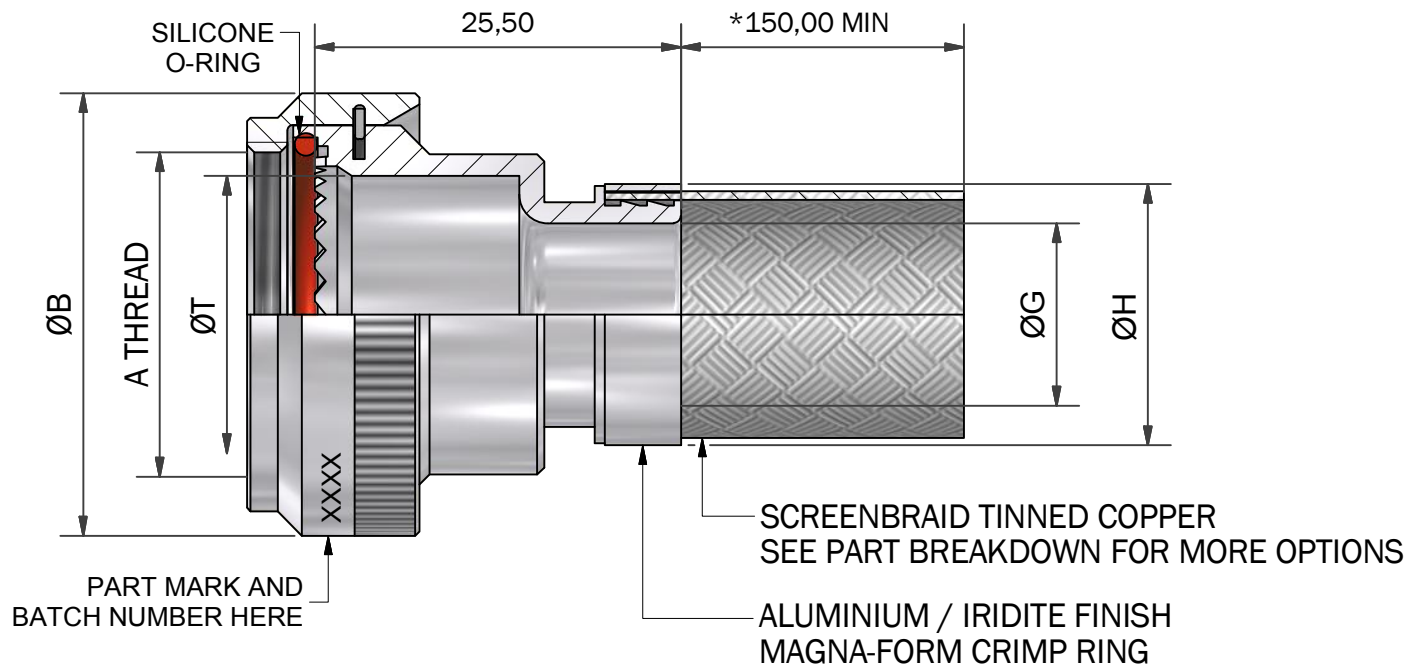

|  |         |  |  |   |            |            |  |  |      |            |             |  |  |  |  |           |  |  |             |  |           |  |  |                  |  |       |      |     |                                   |  |   |   |      |                                    |  |                  |  |        |                                  |  |                                       |  |   |  |  |
|--|---------|--|--|---|------------|------------|--|--|------|------------|-------------|--|--|--|--|-----------|--|--|-------------|--|-----------|--|--|------------------|--|-------|------|-----|-----------------------------------|--|---|---|------|------------------------------------|--|------------------|--|--------|----------------------------------|--|---------------------------------------|--|---|--|--|
| <table border="1"> <tr> <td>DRAWN</td> <td colspan="2">P.FRYER</td> <td>DATE</td> <td>10/11/2010</td> </tr> <tr> <td>SALES APPR</td> <td colspan="2"></td> <td>DATE</td> <td>10/11/2010</td> </tr> <tr> <td>DESIGN APPR</td> <td colspan="2"></td> <td colspan="2">UNLESS OTHERWISE SPECIFIED ALL DIMENSIONS IN MILLIMETRES</td> </tr> <tr> <td>PROD APPR</td> <td colspan="2"></td> <td colspan="2">GENERAL TOL</td> </tr> <tr> <td>QUAL APPR</td> <td colspan="2"></td> <td colspan="2">LINEAR +/-0,25MM</td> </tr> <tr> <td>ISSUE</td> <td>REV.</td> <td>DCR</td> <td colspan="2">3RD ANGLE PROJECTION NOT TO SCALE</td> </tr> <tr> <td>2</td> <td>1</td> <td>3969</td> <td colspan="2">MATERIAL SEE PART NUMBER BREAKDOWN</td> </tr> <tr> <td colspan="2">NCAGE CODE U5792</td> <td>WEIGHT</td> <td colspan="2">FINISH SEE PART NUMBER BREAKDOWN</td> </tr> </table> | DRAWN   | P.FRYER  |  | DATE  | 10/11/2010 | SALES APPR |  |  | DATE | 10/11/2010 | DESIGN APPR |  |  | UNLESS OTHERWISE SPECIFIED ALL DIMENSIONS IN MILLIMETRES |  | PROD APPR |  |  | GENERAL TOL |  | QUAL APPR |  |  | LINEAR +/-0,25MM |  | ISSUE | REV. | DCR | 3RD ANGLE PROJECTION NOT TO SCALE |  | 2 | 1 | 3969 | MATERIAL SEE PART NUMBER BREAKDOWN |  | NCAGE CODE U5792 |  | WEIGHT | FINISH SEE PART NUMBER BREAKDOWN |  | PART NUMBER:<br><br><b>70F SERIES</b> |  | TITLE:<br><br><b>BRAID TAIL BACKSHELL</b> |  | <br><b>Polamco</b><br> |
| DRAWN  | P.FRYER |  | DATE   | 10/11/2010  |            |            |  |  |      |            |             |  |  |  |  |           |  |  |             |  |           |  |  |                  |  |       |      |     |                                   |  |   |   |      |                                    |  |                  |  |        |                                  |  |                                       |  |   |  |  |
| SALES APPR   |         |  | DATE   | 10/11/2010  |            |            |  |  |      |            |             |  |  |  |  |           |  |  |             |  |           |  |  |                  |  |       |      |     |                                   |  |   |   |      |                                    |  |                  |  |        |                                  |  |                                       |  |   |  |  |
| DESIGN APPR  |         |  | UNLESS OTHERWISE SPECIFIED ALL DIMENSIONS IN MILLIMETRES |   |            |            |  |  |      |            |             |  |  |  |  |           |  |  |             |  |           |  |  |                  |  |       |      |     |                                   |  |   |   |      |                                    |  |                  |  |        |                                  |  |                                       |  |   |  |  |
| PROD APPR  |         |  | GENERAL TOL  |   |            |            |  |  |      |            |             |  |  |  |  |           |  |  |             |  |           |  |  |                  |  |       |      |     |                                   |  |   |   |      |                                    |  |                  |  |        |                                  |  |                                       |  |   |  |  |
| QUAL APPR  |         |  | LINEAR +/-0,25MM   |   |            |            |  |  |      |            |             |  |  |  |  |           |  |  |             |  |           |  |  |                  |  |       |      |     |                                   |  |   |   |      |                                    |  |                  |  |        |                                  |  |                                       |  |   |  |  |
| ISSUE  | REV.    | DCR  | 3RD ANGLE PROJECTION NOT TO SCALE                        |   |            |            |  |  |      |            |             |  |  |  |  |           |  |  |             |  |           |  |  |                  |  |       |      |     |                                   |  |   |   |      |                                    |  |                  |  |        |                                  |  |                                       |  |   |  |  |
| 2  | 1       | 3969   | MATERIAL SEE PART NUMBER BREAKDOWN                       |   |            |            |  |  |      |            |             |  |  |  |  |           |  |  |             |  |           |  |  |                  |  |       |      |     |                                   |  |   |   |      |                                    |  |                  |  |        |                                  |  |                                       |  |   |  |  |
| NCAGE CODE U5792   |         | WEIGHT   | FINISH SEE PART NUMBER BREAKDOWN                         |   |            |            |  |  |      |            |             |  |  |  |  |           |  |  |             |  |           |  |  |                  |  |       |      |     |                                   |  |   |   |      |                                    |  |                  |  |        |                                  |  |                                       |  |   |  |  |
| ASSY USED ON: MIL-DTL-38999 SERIES I   |         | THIS DRAWING IS COPYRIGHT AND THE PROPERTY OF POLAMCO LTD IT MUST NOT BE COPIED, USED FOR MANUFACTURE OR OTHERWISE DISCLOSED WITHOUT PRIOR WRITTEN CONSENT OF THE COMPANY. |  | POLAMCO LTD, WESTON LOCK, LOWER BRISTOL ROAD BATH BA2 1EP |            |            |  |  |      |            |             |  |  |  |  |           |  |  |             |  |           |  |  |                  |  |       |      |     |                                   |  |   |   |      |                                    |  |                  |  |        |                                  |  |                                       |  |   |  |  |
| SHT 1  |         | DRAWING NO: P17660   |  |   |            |            |  |  |      |            |             |  |  |  |  |           |  |  |             |  |           |  |  |                  |  |       |      |     |                                   |  |   |   |      |                                    |  |                  |  |        |                                  |  |                                       |  |   |  |  |

TABLE 1

| SHELL SIZE | A THREAD       | ØB MAX | ØT MIN | C ±0,5 | D MAX | E MAX | F MAX | K ±0,5 |
|------------|----------------|--------|--------|--------|-------|-------|-------|--------|
| 09         | 7/16-28 UNEF   | 18,0   | 6,8    | 16,4   | 17,1  | 22,7  | 24,0  | 15,0   |
| 11         | 9/16-24 UNEF   | 21,0   | 10,2   | 17,2   | 18,2  | 26,2  | 25,7  | 17,0   |
| 13         | 11/16-24 UNEF  | 24,5   | 13,1   | 17,6   | 18,6  | 29,2  | 27,2  | 18,0   |
| 15         | 13/16-20 UNEF  | 27,8   | 16,2   | 18,5   | 19,5  | 32,2  | 28,7  | 20,0   |
| 17         | 15/16-20 UNEF  | 30,8   | 19,3   | 20,2   | 20,3  | 35,7  | 30,4  | 21,5   |
| 19         | 1 1/16-18 UNEF | 34,1   | 22,3   | 19,6   | 20,8  | 39,7  | 32,0  | 23,0   |
| 21         | 1 3/16-18 UNEF | 37,3   | 25,8   | 20,4   | 21,7  | 42,2  | 33,6  | 25,0   |
| 23         | 1 5/16-18 UNEF | 41,0   | 28,3   | 20,8   | 22,0  | 45,2  | 35,1  | 26,0   |
| 25         | 1 7/16-18 UNEF | 43,7   | 31,5   | 21,7   | 22,9  | 48,2  | 36,6  | 28,0   |

TABLE 2

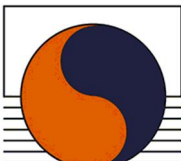
| ENTRY SIZE | ØG MIN | ØH MAX |
|------------|--------|--------|
| 03         | 4,7    | 13,1   |
| 04         | 6,3    | 13,1   |
| 05         | 7,9    | 13,1   |
| 06         | 9,5    | 17,9   |
| 07         | 11,1   | 17,9   |
| 08         | 12,7   | 17,9   |
| 09         | 14,2   | 17,9   |
| 10         | 15,8   | 24,2   |
| 11         | 17,4   | 24,2   |
| 12         | 19,0   | 24,2   |
| 13         | 20,6   | 24,2   |
| 14         | 22,2   | 30,6   |
| 15         | 23,8   | 30,6   |
| 16         | 25,4   | 30,6   |
| 17         | 27,0   | 30,6   |
| 18         | 28,6   | 37,4   |
| 19         | 30,2   | 37,4   |
| 20         | 31,8   | 37,4   |
| 21         | 33,3   | 37,4   |
| 22         | 35,0   | 44,0   |
| 23         | 36,5   | 44,0   |
| 24         | 38,1   | 44,0   |

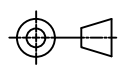
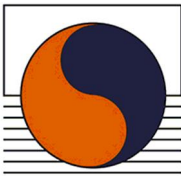

TABLE 3

| CODE | FINISH  |
|------|---|
| C    | ELECTROLESS NICKEL                                  |
| B    | CADMIUM OLIVE DRAB OVER ELECTROLESS NICKEL          |
| ZB   | ZINC COBALT OLIVE DRAB OVER ELECTROLESS NICKEL      |
| ZN   | ZINC NICKEL BLACK PASSIVATE OVER ELECTROLESS NICKEL |

LIST NOT EXHAUSTIVE, SEE PLATING TABLE FOR OTHER OPTIONS

70F1-17-08-1-C-N

SERIES \_\_\_\_\_  
 CONNECTOR INTERFACE \_\_\_\_\_  
 ANGLE \_\_\_\_\_  
 SHELL SIZE (TABLE 1) \_\_\_\_\_  
 ENTRY SIZE (TABLE 2) \_\_\_\_\_  
 MATERIAL \_\_\_\_\_  
 ALUMINIUM ALLOY  
 FINISH (TABLE 3) \_\_\_\_\_  
 NICKEL PLATED BRAID TAIL \_\_\_\_\_  
 OMIT FOR STANDARD (TINNED COPPER)

|                  |         |  |            |   |  |                                |                                      |  |   |
|------------------|---------|--|------------|---|--|--------------------------------|--------------------------------------|--|---|
| DRAWN            | P.FRYER | DATE   | 10/11/2010 |  3RD ANGLE PROJECTION NOT TO SCALE | PART NUMBER:   | 70F SERIES                     |                                      |  | <br>Polamco<br> |
| SALES APPR       |         | DATE   | 10/11/2010 |   |  | TITLE:<br>BRAID TAIL BACKSHELL | ASSY USED ON: MIL-DTL-38999 SERIES I |  |   |
| DESIGN APPR      |         | UNLESS OTHERWISE SPECIFIED ALL DIMENSIONS IN MILLIMETRES |            | MATERIAL<br>SEE PART NUMBER BREAKDOWN<br>FINISH<br>SEE PART NUMBER BREAKDOWN  | THIS DRAWING IS COPYRIGHT AND THE PROPERTY OF POLAMCO LTD IT MUST NOT BE COPIED, USED FOR MANUFACTURE OR OTHERWISE DISCLOSED WITHOUT PRIOR WRITTEN CONSENT OF THE COMPANY. |                                |                                      |  |   |
| PROD APPR        |         | GENERAL TOL<br>LINEAR +/-0,25MM<br>ANGULAR +/- 1°        |            |   | POLAMCO LTD, WESTON LOCK, LOWER BRISTOL ROAD BATH BA2 1EP  |                                |                                      |  |   |
| QUAL APPR        |         | ISSUE  | REV.       | DCR   | SHT  | DRAWING NO:                    |                                      |  |   |
|                  |         | 2  | 1          | 3969  | 2  | P17660                         |                                      |  |   |
| NCAGE CODE U5792 |         | WEIGHT   |            |   |  |                                |                                      |  |   |