



Part Number : [1204040017](#)

Product Description : Ultra-Lock 2.0 (M12) Receptacle, 5 Poles, Female (Straight), A-Coded, Front Panel Mount, PG9 Mounting Threads, PCB Pins

Series Number : 120404

Status : Active

Product Category : Circular Industrial Connectors

Engineering Number : YR5J20000

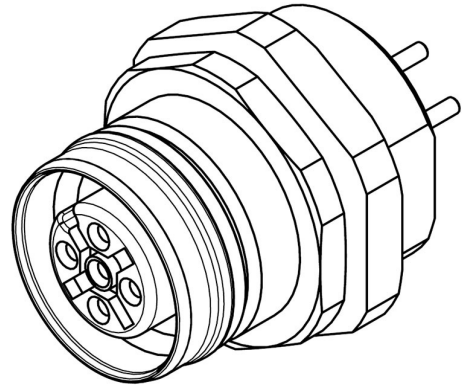

For illustration only. Pole size may deviate from image.

Documents & Resources

Drawings

[1204040017_sd.pdf](#)

Product Environment Compliance

Compliance

GADSL/IMDS	Not Relevant
China RoHS	Not Relevant
EU ELV	Compliant with Exemption 3 per 2000/53/EC
Low-Halogen Status	Not Relevant
REACH SVHC	Contains Lead per D(2023)3788-DC (14 Jun 2023)
EU RoHS	Compliant with Exemption 6(c) per EU 2015/863

Multiple Part Product Compliance Statements

- Eu RoHS
- REACH SVHC
- Low-Halogen

Multiple Part Industry Compliance Documents

- IPC 1752A Class C
- IPC 1752A Class D
- Molex Product Compliance Declaration

- IEC-62474

- chemSHERPA (xml)

EU RoHS Certificate of Compliance

Part Details

General

Status	Active
Category	Circular Industrial Connectors
Series	120404
Description	Ultra-Lock 2.0 (M12) Receptacle, 5 Poles, Female (Straight), A-Coded, Front Panel Mount, PG9 Mounting Threads, PCB Pins
IP Rating	IP67, IP69K
Product Name	Ultra-Lock 2.0 (M12)
Type	PCB Mount
UPC	195842255784

Agency

CSA	LR6837
-----	--------

Electrical

Current - Maximum per Contact	4.0A
Voltage - Maximum	60V

Physical

Coupling Type	Internal Thread Push to Lock
Gender	Female
Keyway	A-Coded
Length	N/A
Material - Component	Nickel-plated Brass
Mounting Thread Size	PG9
Net Weight	15.300/g
Orientation	Straight
Panel Mount	Front
Poles	5

Temperature Range - Operating	-40° to +85°C
Wire/Cable Type	UL 1569
Wire Size (AWG)	N/A

This document was generated on Feb 13, 2025