

DATASHEET

SIEMENS

6SL3000-0BE21-6DA0

OTHER SYMBOLS:

6SL30000BE216DA0, 6SL30000BE21 6DA0, 6SL30000BE21-6DA0, 6SL3000 0BE216DA0, 6SL3000 0BE21 6DA0,
6SL3000 0BE21-6DA0, 6SL3000-0BE216DA0, 6SL3000-0BE21 6DA0, 6SL3000-0BE21-6DA0

**RGB ELEKTRONIKA AGACIAK CIACIEK
SPÓŁKA JAWNA**

Jana Długosza 2-6 Street
51-162 Wrocław
Poland

✉ biuro@rgbelektronika.pl

☎ +48 71 325 15 05



www.rgbelektronika.pl



www.rgbautomatyka.pl

YOUR PARTNER IN MAINTENANCE

Repair **this product** with RGB ELEKTRONIKA

[ORDER A DIAGNOSIS »](#)



At our premises in Wrocław, we have a fully equipped servicing facility. Here we perform all the repair works and test each later sold unit. Our trained employees, equipped with a wide variety of tools and having several testing stands at their disposal, are a guarantee of the highest quality service.

Buy **this product** at RGB AUTOMATYKA

[BUY »](#)

SINAMICS G130 / G150

Line Harmonics Filters

Operating Instructions · 10/2008

SINAMICS

SIEMENS

SIEMENS

SINAMICS

SINAMICS G130/G150 Line harmonics filters

Operating Instructions

Safety information

1

General

2

Mechanical installation

3

Electrical installation

4

Maintenance and servicing

5

Technical specifications

6

Control version V2.6 SP1



10/2008

A5E01347987A

Legal information

Warning notice system

This manual contains notices you have to observe in order to ensure your personal safety, as well as to prevent damage to property. The notices referring to your personal safety are highlighted in the manual by a safety alert symbol, notices referring only to property damage have no safety alert symbol. These notices shown below are graded according to the degree of danger.

 DANGER
indicates that death or severe personal injury will result if proper precautions are not taken.
 WARNING
indicates that death or severe personal injury may result if proper precautions are not taken.
 CAUTION
with a safety alert symbol, indicates that minor personal injury can result if proper precautions are not taken.
CAUTION
without a safety alert symbol, indicates that property damage can result if proper precautions are not taken.
NOTICE
indicates that an unintended result or situation can occur if the corresponding information is not taken into account.

If more than one degree of danger is present, the warning notice representing the highest degree of danger will be used. A notice warning of injury to persons with a safety alert symbol may also include a warning relating to property damage.

Qualified Personnel

The device/system may only be set up and used in conjunction with this documentation. Commissioning and operation of a device/system may only be performed by **qualified personnel**. Within the context of the safety notes in this documentation qualified persons are defined as persons who are authorized to commission, ground and label devices, systems and circuits in accordance with established safety practices and standards.

Proper use of Siemens products

Note the following:

 WARNING
Siemens products may only be used for the applications described in the catalog and in the relevant technical documentation. If products and components from other manufacturers are used, these must be recommended or approved by Siemens. Proper transport, storage, installation, assembly, commissioning, operation and maintenance are required to ensure that the products operate safely and without any problems. The permissible ambient conditions must be adhered to. The information in the relevant documentation must be observed.

Trademarks

All names identified by ® are registered trademarks of the Siemens AG. The remaining trademarks in this publication may be trademarks whose use by third parties for their own purposes could violate the rights of the owner.

Disclaimer of Liability

We have reviewed the contents of this publication to ensure consistency with the hardware and software described. Since variance cannot be precluded entirely, we cannot guarantee full consistency. However, the information in this publication is reviewed regularly and any necessary corrections are included in subsequent editions.

Table of contents

1	Safety information	7
1.1	Warnings.....	7
1.2	Safety and operating instructions.....	8
2	General	9
3	Mechanical installation	15
3.1	General	15
3.2	Dimension drawings.....	16
4	Electrical installation	19
5	Maintenance and servicing	25
6	Technical specifications	27

Safety information

1

1.1 Warnings



! WARNING
<p>Hazardous voltages are present when electrical equipment is in operation. Severe personal injury or substantial material damage may result if these warnings are not observed.</p> <p>Only qualified personnel are permitted to work on or around the equipment. This personnel must be thoroughly familiar with all the warnings and maintenance procedures described in these operating instructions.</p> <p>The successful and safe operation of this device is dependent on correct transport, proper storage and installation, as well as careful operation and maintenance.</p> <p>National safety guidelines must be observed.</p>



! DANGER
<p>Five safety rules</p> <p>When carrying out any kind of work on electrical devices, the "five safety rules" must always be observed:</p> <ol style="list-style-type: none">1. Disconnect the system.2. Protect against reconnection.3. Make sure that the equipment is de-energized.4. Ground and short-circuit.5. Cover or enclose adjacent components that are still live.

NOTICE
For a UL-approved system use 60/75°C copper conductors only.

1.2 Safety and operating instructions



DANGER

This equipment is used in industrial high-voltage installations. During operation, this equipment contains rotating and live, bare parts. For this reason, they could cause severe injury or significant material damage if the required covers are removed, if they are used or operated incorrectly, or have not been properly maintained.

When the machines are used in non-industrial areas, the installation location must be protected against unauthorized access (protective fencing, appropriate signs).

Prerequisites

Those responsible for protecting the plant must ensure the following:

- The basic planning work for the plant and the transport, assembly, installation, commissioning, maintenance, and repair work is carried out by qualified personnel and/or checked by experts responsible.
- The operating manual and machine documentation are always available.
- The technical specifications regarding the applicable installation, connection, environmental, and operating conditions are always observed.
- The plant-specific assembly and safety guidelines are observed and personal protection equipment is used.
- Unqualified personnel are forbidden from using these machines and working near them.

This operating manual is intended for qualified personnel and only contain information and notes relating to the intended purpose of the machines.

The operating manual and machine documentation are written in different languages as specified in the delivery contracts.

Note

We recommend engaging the support and services of your local Siemens service center for all planning, installation, commissioning and maintenance work.

General

Description

Line harmonics filters are drive components designed for installation in electrical systems or machines.

They must not be used in other electrical consumers since this could destroy the devices.

 **WARNING**

Line harmonics filters must only be connected to symmetrical networks otherwise they can be destroyed.

Assignment of line harmonics filter and converter G130/G150

Table 2- 1 Assignment of line harmonics filter, converter G130/G150

Line harmonics filter	Associated converter G130 ¹⁾	Associated converter cabinet G150 ²⁾	Unit rating of the converter
Line voltage 380 – 480 V 3 AC			
6SL3000-0JE36-1AA0	6SL3310-1GE33-1AA0	6SL3710-1GE33-1_A0	160 kW
	6SL3310-1GE33-8AA0	6SL3710-1GE33-8_A0	200 kW
	6SL3310-1GE35-0AA0	6SL3710-1GE35-0_A0	250 kW
	6SL3310-1GE36-1AA0	6SL3710-1GE36-1_A0	315 kW
6SL3000-0JE38-4AA0	6SL3310-1GE37-5AA0	6SL3710-1GE37-5_A0	400 kW
	6SL3310-1GE38-4AA0	6SL3710-1GE38-4_A0	450 kW
6SL3000-0JE41-0AA0	6SL3310-1GE41-0AA0	6SL3710-1GE41-0_A0	560 kW
Line voltage 500 – 600 V 3 AC			
6SL3000-0JH33-3AA0	6SL3310-1GF31-8AA0	6SL3710-1GF31-8_A0	110 kW
	6SL3310-1GF32-2AA0	6SL3710-1GF32-2_A0	132 kW
	6SL3310-1GF32-6AA0	6SL3710-1GF32-6_A0	160 kW
	6SL3310-1GF33-3AA0	6SL3710-1GF33-3_A0	200 kW
6SL3000-0JH34-7AA0	6SL3310-1GF34-1AA0	6SL3710-1GF34-1_A0	250 kW
	6SL3310-1GF34-7AA0	6SL3710-1GF34-7_A0	315 kW
6SL3000-0JH35-8AA0	6SL3310-1GF35-8AA0	6SL3710-1GF35-8_A0	400 kW
6SL3000-0JH38-1AA0	6SL3310-1GF37-4AA0	6SL3710-1GF37-4_A0	500 kW
	6SL3310-1GF38-1AA0	6SL3710-1GF38-1_A0	560 kW
Line voltage 660 – 690 V 3 AC			
6SL3000-0JH33-3AA0	6SL3310-1GH31-8AA0	6SL3710-1GH31-8_A0	160 kW
	6SL3310-1GH32-2AA0	6SL3710-1GH32-2_A0	200 kW
	6SL3310-1GH32-6AA0	6SL3710-1GH32-6_A0	250 kW
	6SL3310-1GH33-3AA0	6SL3710-1GH33-3_A0	315 kW
6SL3000-0JH34-7AA0	6SL3310-1GH34-1AA0	6SL3710-1GH34-1_A0	400 kW
	6SL3310-1GH34-7AA0	6SL3710-1GH34-7_A0	450 kW
6SL3000-0JH35-8AA0	6SL3310-1GH35-8AA0	6SL3710-1GH35-8_A0	560 kW
6SL3000-0JH38-1AA0	6SL3310-1GH37-4AA0	6SL3710-1GH37-4_A0	710 kW
	6SL3310-1GH38-1AA0	6SL3710-1GH38-1_A0	800 kW

¹⁾ With G130: only in conjunction with a line reactor and line contactor/circuit breaker (see table below)

²⁾ With G150: only in conjunction with options L23 (line reactor) and L13 (line contactor)/L26 (circuit breaker)

Table 2- 2 Assignment of converter G130, line contactor, and line reactor

SINAMICS G130	Unit rating	Line contactor/circuit breaker	Line reactor
Line voltage 380 – 480 V 3 AC			
6SL3310-1GE33-1AA0	160 kW	3RT1466-6AP36	6SL3000-0CE33-3AA0
6SL3310-1GE33-8AA0	200 kW	3RT1476-6AP36	6SL3000-0CE35-1AA0
6SL3310-1GE35-0AA0	250 kW	3RT1476-6AP36	6SL3000-0CE35-1AA0
6SL3310-1GE36-1AA0	315 kW	3RT1476-6AP36	6SL3000-0CE36-3AA0
6SL3310-1GE37-5AA0	400 kW	3 x 3RT1466-6AP36	6SL3000-0CE37-7AA0
6SL3310-1GE38-4AA0	450 kW	3WL1110-2BB34-4AN2-Z, Z=22	6SL3000-0CE38-7AA0
6SL3310-1GE41-0AA0	560 kW	3WL1210-2BB34-4AN2-Z, Z=22	6SL3000-0CE41-0AA0
Line voltage 500 – 600 V 3 AC			
6SL3310-1GF31-8AA0	110 kW	3RT1456-6AP36	6SL3000-0CH32-2AA0
6SL3310-1GF32-2AA0	132 kW	3RT1456-6AP36	6SL3000-0CH32-2AA0
6SL3310-1GF32-6AA0	160 kW	3RT1466-6AP36	6SL3000-0CH32-7AA0
6SL3310-1GF33-3AA0	200 kW	3RT1466-6AP36	6SL3000-0CH33-4AA0
6SL3310-1GF34-1AA0	250 kW	3RT1476-6AP36	6SL3000-0CH34-8AA0
6SL3310-1GF34-7AA0	315 kW	3RT1476-6AP36	6SL3000-0CH34-8AA0
6SL3310-1GF35-8AA0	400 kW	3RT1476-6AP36	6SL3000-0CH36-0AA0
6SL3310-1GF37-4AA0	450 kW	3 x 3RT1466-6AP36	6SL3000-0CH38-4AA0
6SL3310-1GF38-1AA0	560 kW	3WL1210-4BB34-4AN2-Z, Z=22	6SL3000-0CH38-4AA0
Line voltage 660 – 690 V 3 AC			
6SL3310-1GH31-8AA0	160 kW	3RT1456-6AP36	6SL3000-0CH32-2AA0
6SL3310-1GH32-2AA0	200 kW	3RT1456-6AP36	6SL3000-0CH32-2AA0
6SL3310-1GH32-6AA0	250 kW	3RT1466-6AP36	6SL3000-0CH32-7AA0
6SL3310-1GH33-3AA0	315 kW	3RT1466-6AP36	6SL3000-0CH33-4AA0
6SL3310-1GH34-1AA0	400 kW	3RT1476-6AP36	6SL3000-0CH34-8AA0
6SL3310-1GH34-7AA0	450 kW	3RT1476-6AP36	6SL3000-0CH34-8AA0
6SL3310-1GH35-8AA0	560 kW	3RT1476-6AP36	6SL3000-0CH36-0AA0
6SL3310-1GH37-4AA0	710 kW	3 x 3RT1466-6AP36	6SL3000-0CH38-4AA0
6SL3310-1GH38-1AA0	800 kW	3WL1210-4BB34-4AN2-Z, Z=22	6SL3000-0CH38-4AA0

Line system configurations

If you want to operate the filter modules with line systems not specified in the table below, please contact our technical department.

VDE-compliant line system configuration

With directly grounded star point

With indirectly grounded star point

With isolated star point

Operating the line harmonics filter

Permitted

Permitted

Permitted

Line harmonics filter

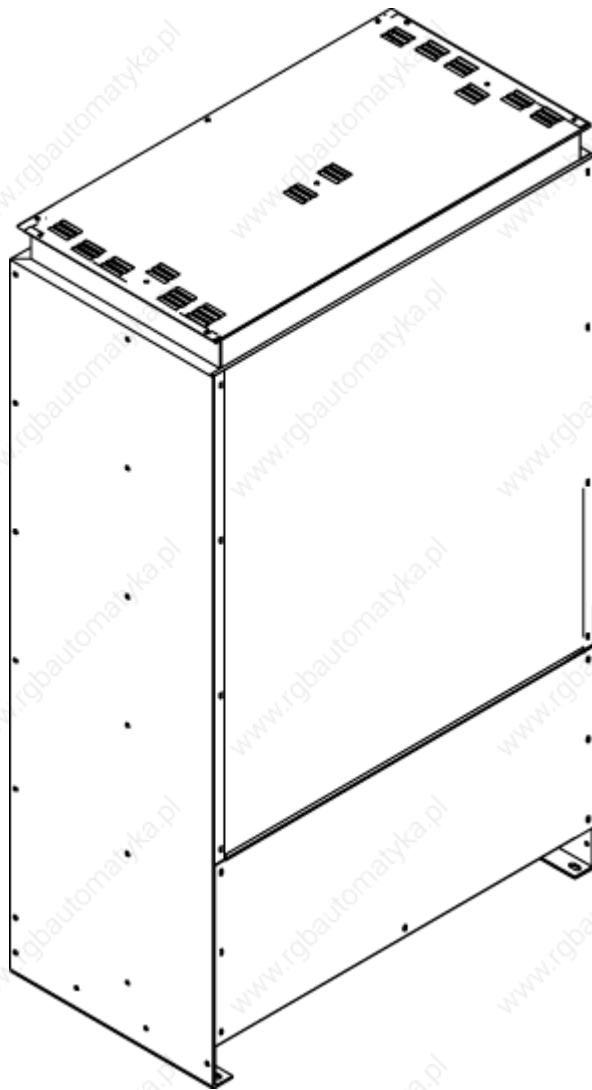

Figure 2-1 Line harmonics filter in the delivery condition with degree of protection IP20

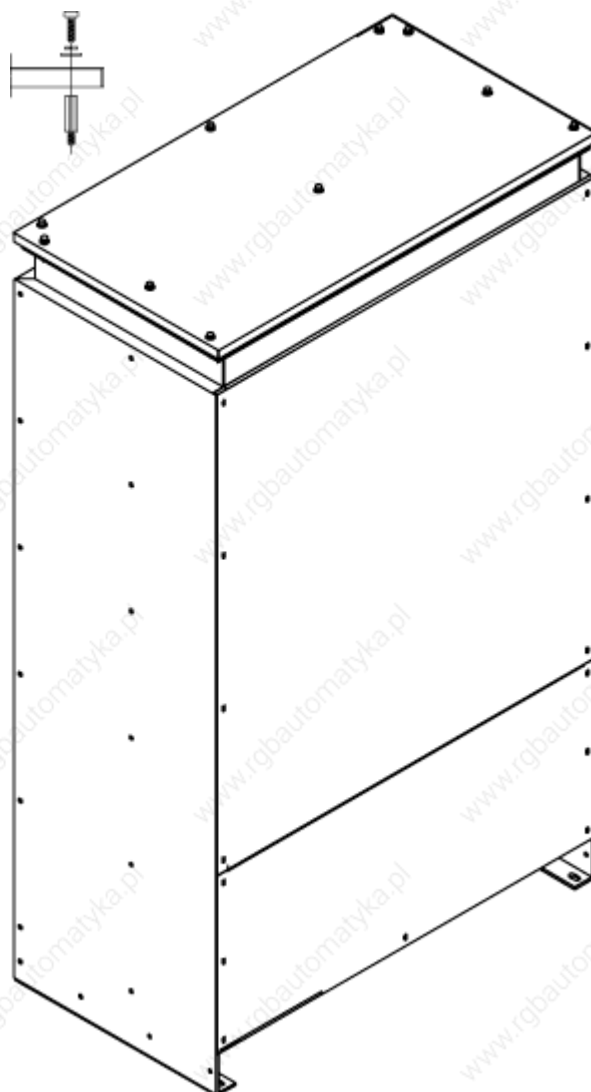



Figure 2-2 Line harmonics filter with mounted canopy and degree of protection IP21

Mechanical installation

3.1 General

 WARNING
<p>To ensure that the devices operate safely and reliably, they must be properly installed and commissioned by qualified personnel, taking into account the warnings provided in these operating instructions.</p> <p>In particular, the general and national installation and safety guidelines for high-voltage installations (e.g. VDE – the Union of German Technical Engineers) as well as the guidelines relating to the proper use of tools and personal protective equipment must be observed.</p> <p>Death, serious injury, or substantial material damage can result if these factors are not taken into account.</p>

Note

A ventilation clearance of at least 60 mm at the rear of the line harmonics filter must be observed.

Natural convection must not be obstructed.

Installing the canopy to increase the degree of protection to IP21

The canopy supplied can be installed on the line harmonics filter to increase the degree of protection to IP21.

To install it, the spacers supplied with the line harmonics filter must be screwed into the holes otherwise used for the cover. Use the screws you removed earlier (incl. washers and retaining rings) to secure the canopy.

3.2 Dimension drawings

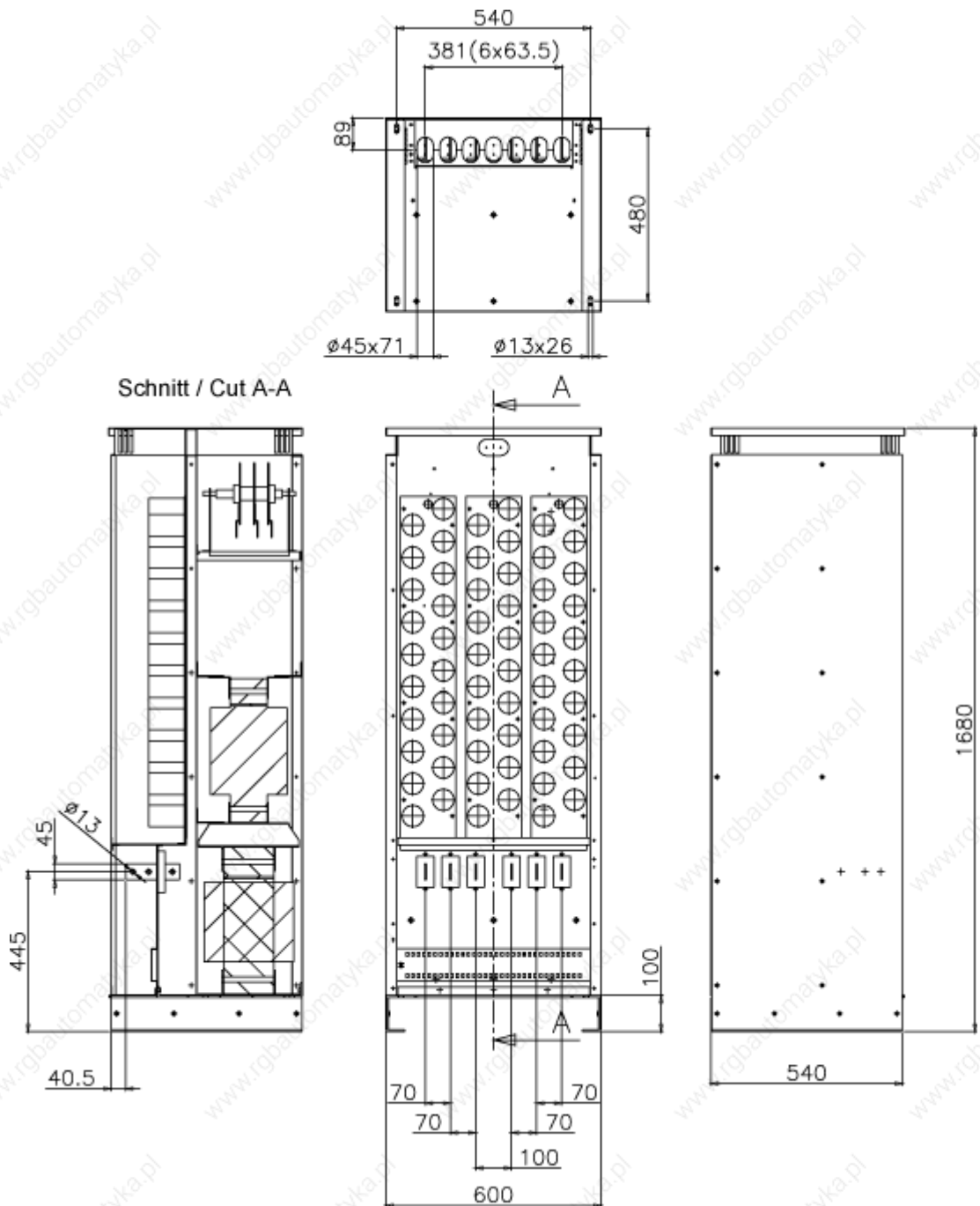

Figure 3-1 Dimension drawing of line harmonics filter: 6SL3000-OJE36-1AA0, 6SL3000-OJH33-3AA0

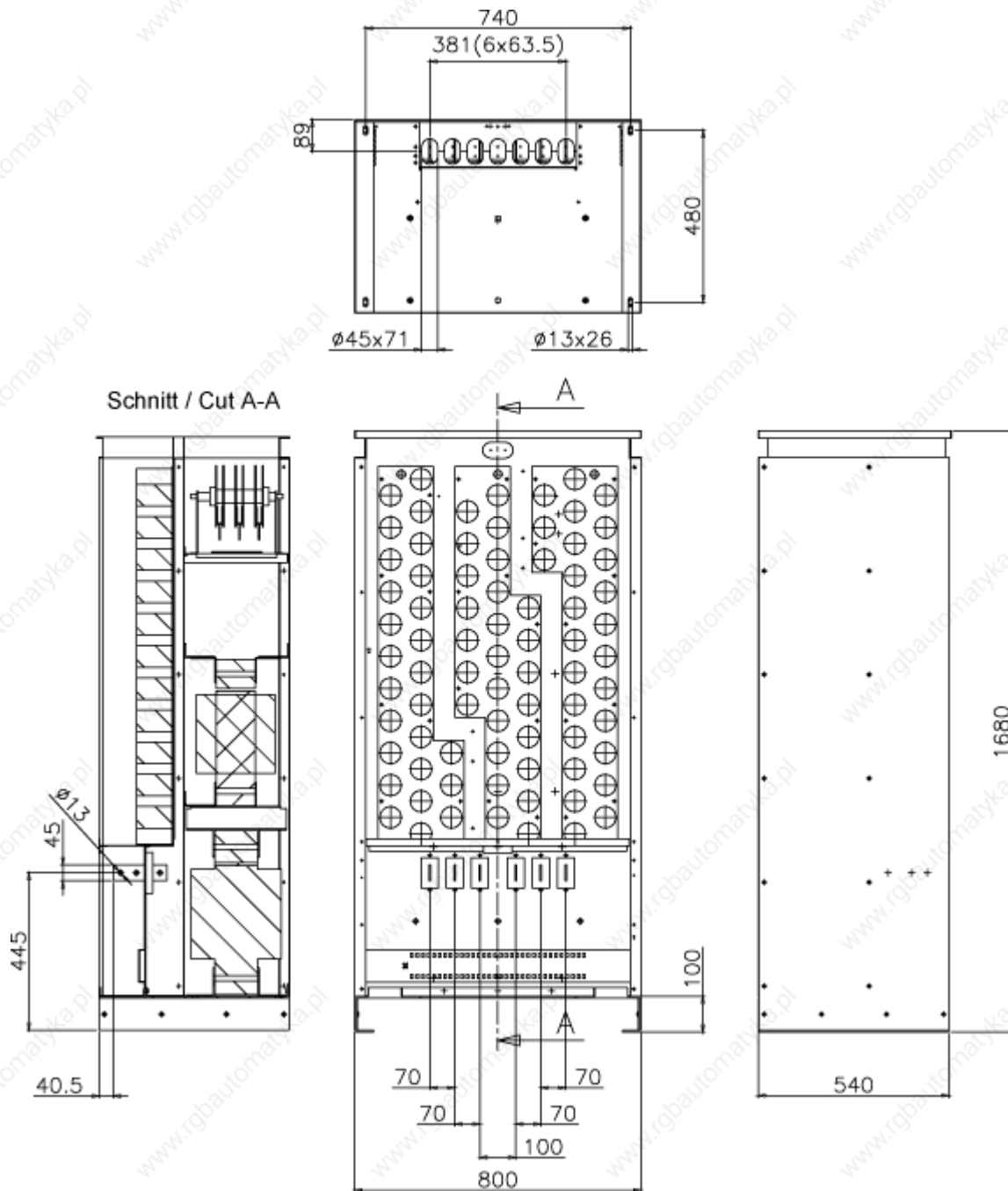

Figure 3-2 Dimension drawing of line harmonics filter: 6SL3000-0JE38-4AA0, 6SL3000-0JH34-7AA0

3.2 Dimension drawings

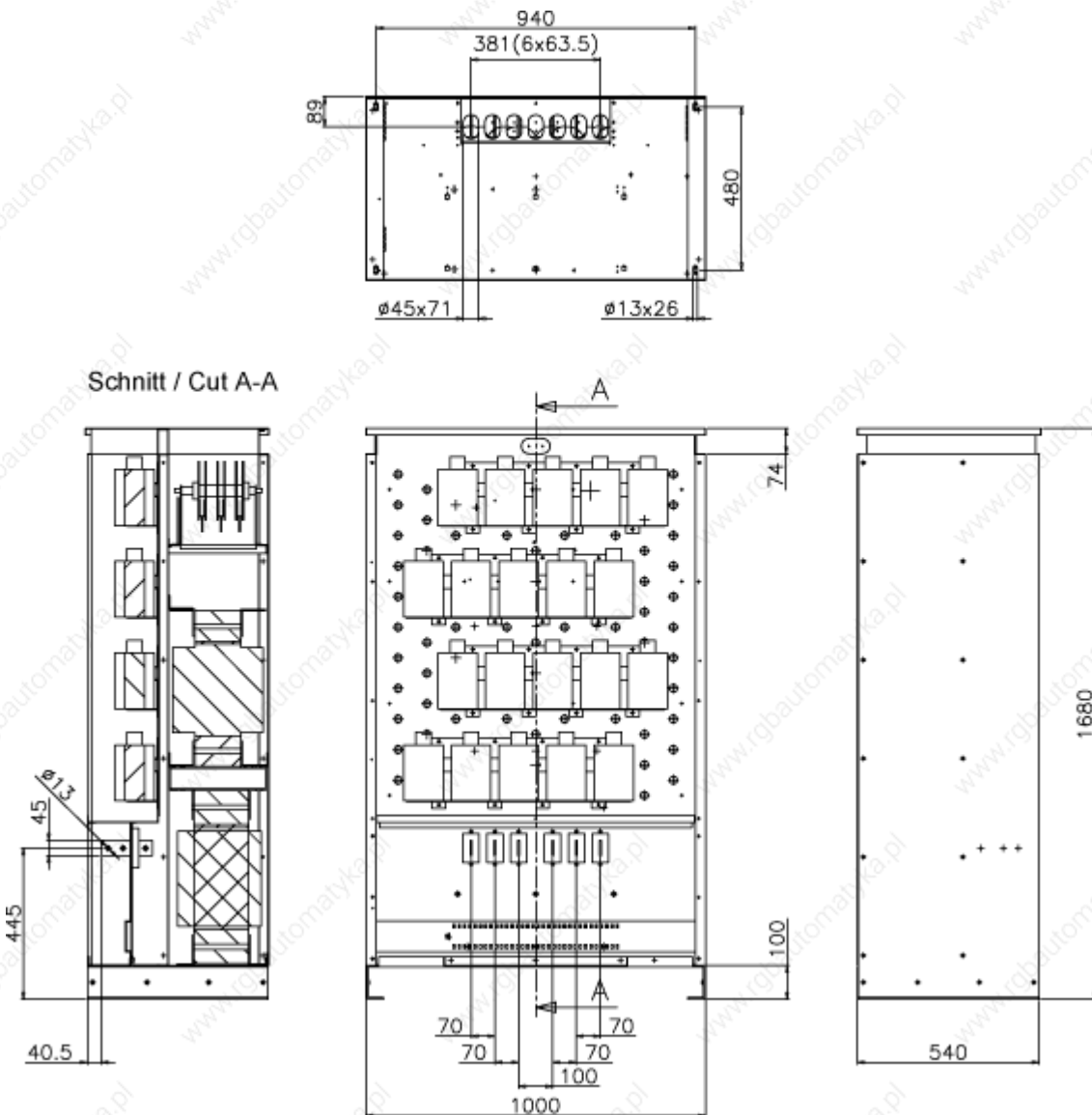



Figure 3-3 Dimension drawing of line harmonics filter: 6SL3000-0JE41-0AA0, 6SL3000-0JH35-8AA0, 6SL3000-0JH38-1AA0

Electrical installation

Important safety precautions

 WARNING
<p>The line harmonics filters are operated with high voltages. All connection procedures must be carried out when the cabinet is de-energized. All work on the device must be carried out by trained personnel only. Death, serious injury, or substantial material damage can result if these warnings are not taken into account.</p> <p>Work on an open device must be carried out with extreme caution. The power and control terminals may be live even when the motor is not running. Due to the capacitors, dangerously high voltage levels are still present in the cabinet up to five minutes after it has been disconnected. For this reason, the cabinet should not be opened until a reasonable period of time has elapsed.</p> <p>The operator is responsible for ensuring that the motor, converter, and other devices are installed and connected in accordance with the recognized technical rules in the country of installation and applicable regional guidelines. Special attention should be paid to cable dimensioning, fuses, grounding, shutdown, disconnection, and overcurrent protection.</p> <p>If an item of protective gear trips in a branch circuit, a leakage current may have been disconnected. To reduce the risk of fire or an electric shock, the current-conducting parts and other components in the cabinet unit should be inspected and damaged parts replaced. When an item of protective gear trips, the cause of the trip must be identified and rectified.</p> <p>When the line harmonics filter is connected to a network with a line frequency of 60 Hz, the cable jumpers must be removed in accordance with the instructions in the device (see interface overviews below).</p>

Tightening torques for connecting current-carrying parts

When securing connections for current-carrying parts (e.g. copper bars), you must observe the following tightening torques.

Table 4- 1 Tightening torques for connecting current-carrying parts

Bolt	Torque
M6	6 Nm
M8	13 Nm
M10	25 Nm
M12	50 Nm

Interface overview

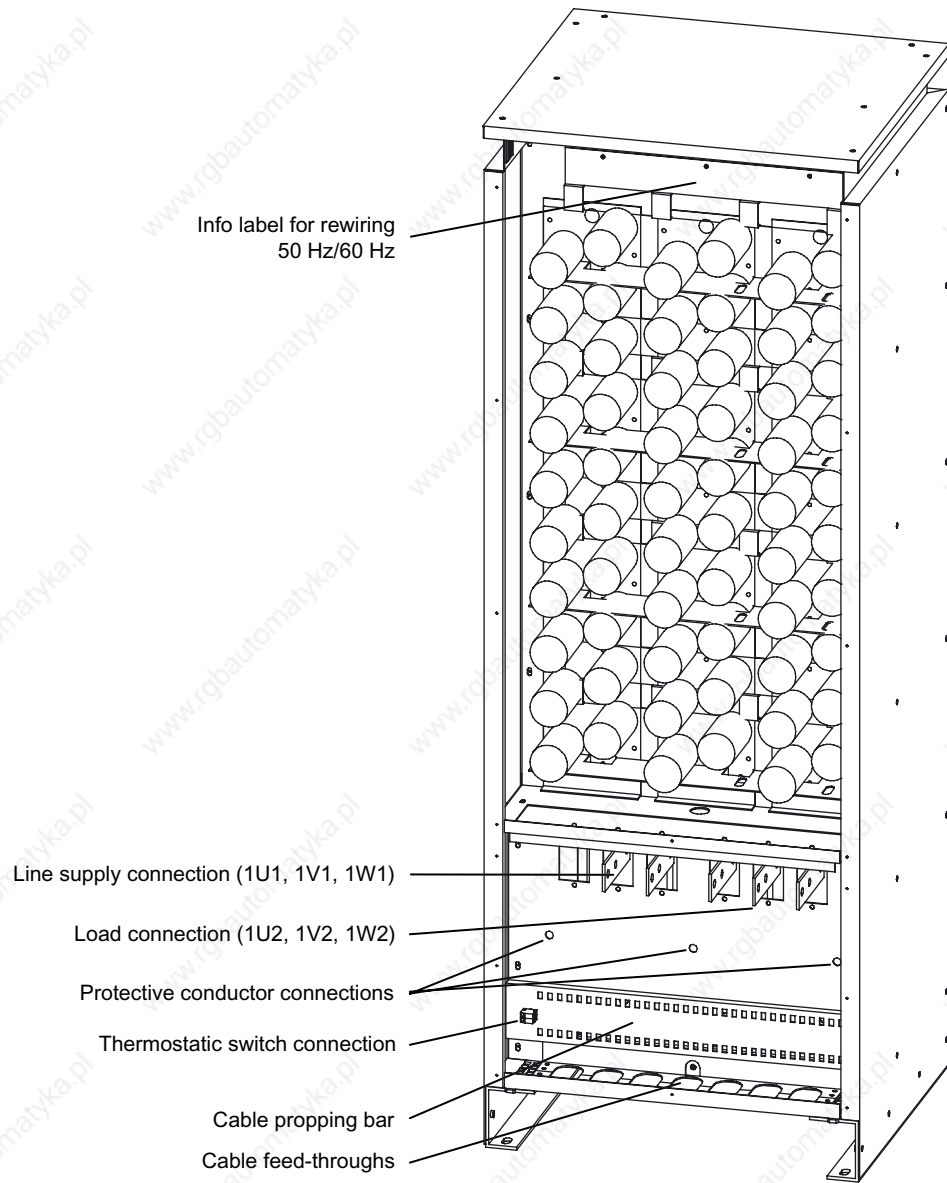

Figure 4-1 Connection overview of the Line Harmonics Filter (600 mm wide)

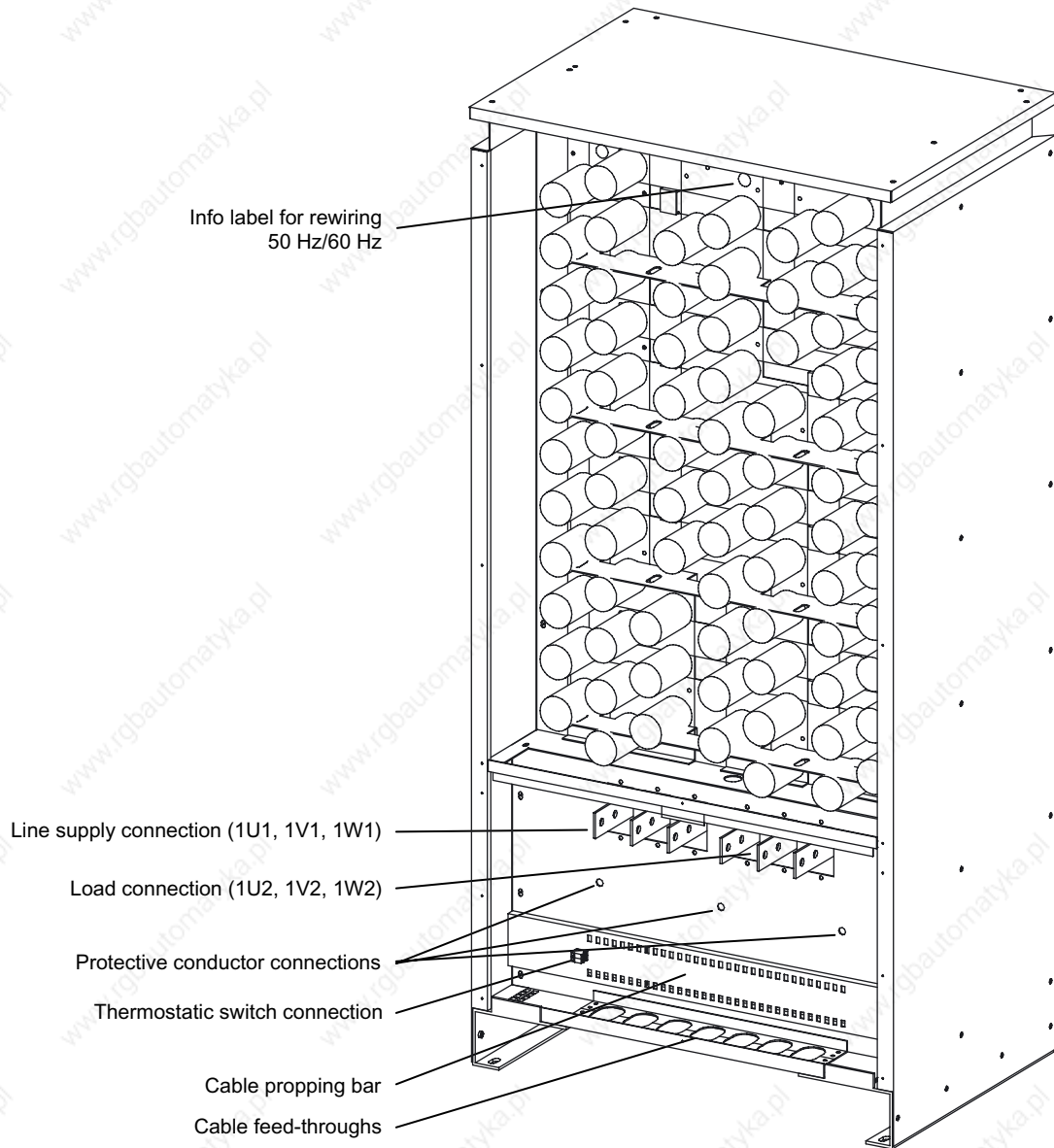

Figure 4-2 Connection overview of the Line Harmonics Filter (800 mm wide)

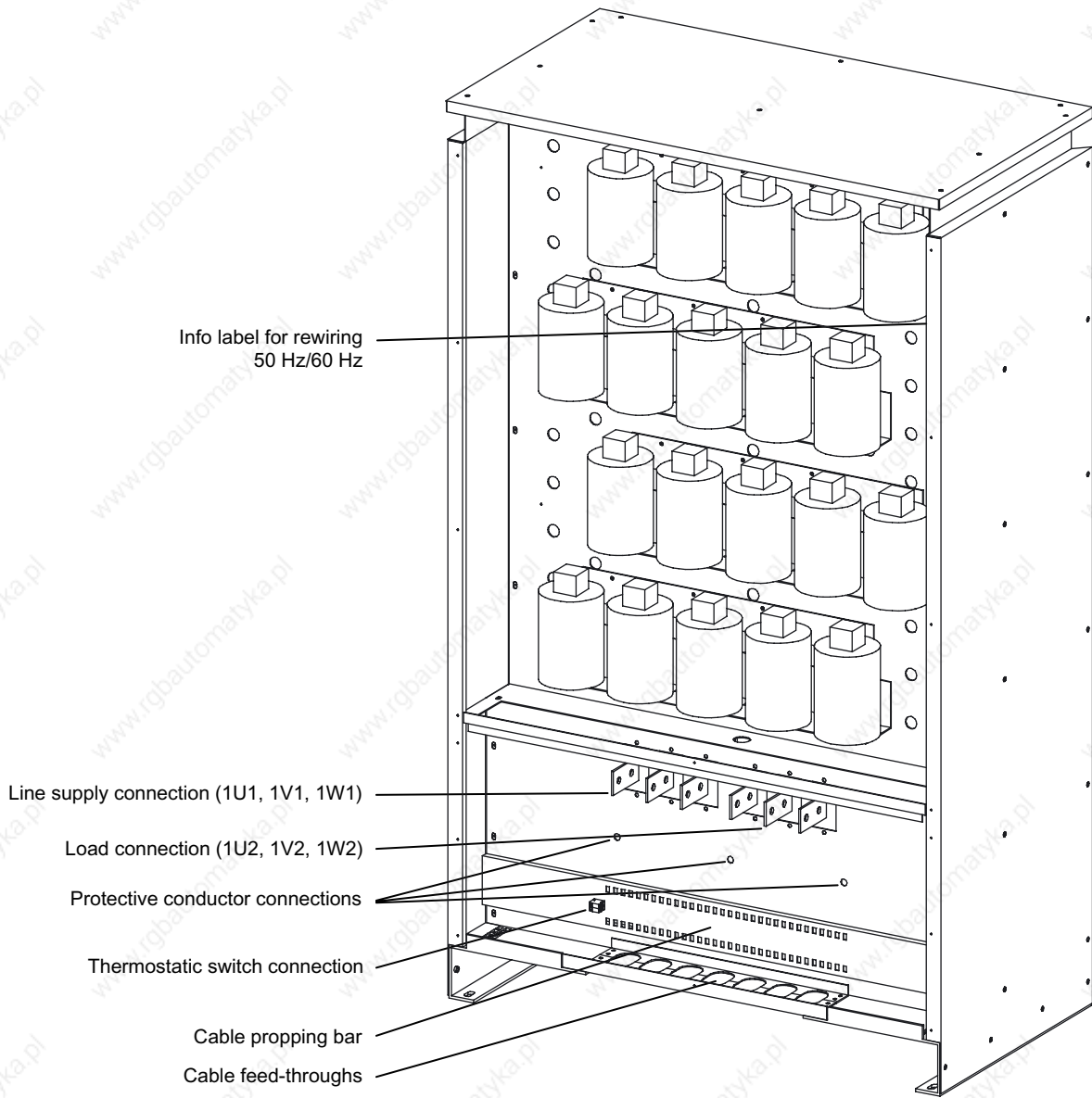

Figure 4-3 Connection overview of the Line Harmonics Filter (1000 mm wide)

Connecting the Line Harmonics Filter for SINAMICS G150

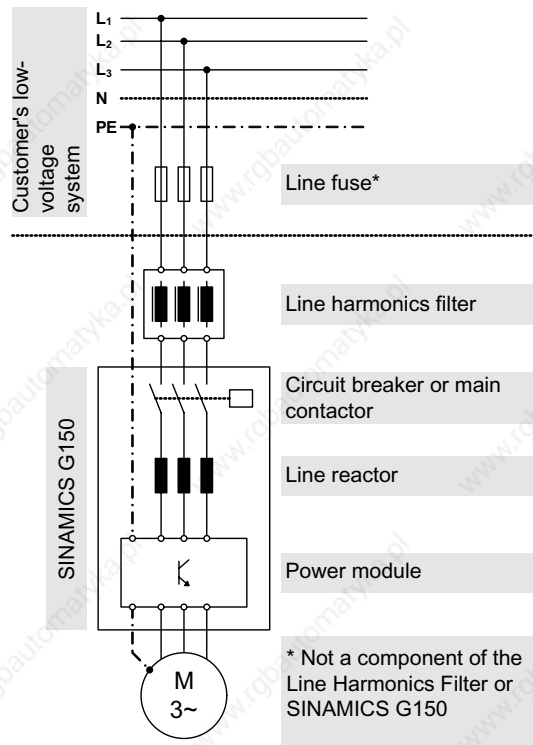

Figure 4-4 Connecting the Line Harmonics Filter for SINAMICS G150

Connecting the Line Harmonics Filter for SINAMICS G130

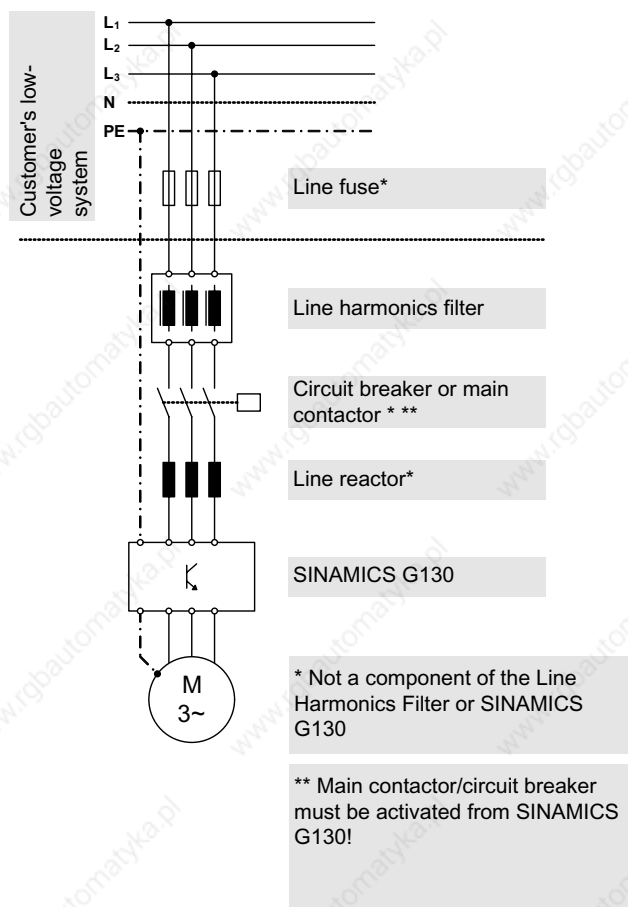

Figure 4-5 Connecting the Line Harmonics Filter for SINAMICS G130

Thermostatic switch connection

A thermostatic switch is installed to protect the integrated reactors against overload. Its floating contacts must be integrated in the fault chain on the line side.

Table 4- 2 Thermostatic switch connection

Terminal	Description of function
T1	Thermostatic switch connection
T2	Thermostatic switch connection

Max. connectable cross-section: 6 mm²

Rewiring when the line frequency is changed from 50 Hz to 60 Hz

When the line harmonics filter is connected to a network with a line frequency of 60 Hz, the cable jumpers must be removed in accordance with the instructions in the device (see the interface overviews).

Maintenance and servicing

Maintenance and servicing are not carried out for the line harmonics filter.

If a fault occurs, please contact Technical Support.

Technical support

We offer technical support in both German and English for products, systems, and solutions deployed in drive and automation systems.

In special cases, help is available from professional, trained, and experienced specialists via teleservice and video conferencing.

Free Contact – providing you with free technical support

- In Europe / Africa
Tel.: +49 (0)180 50 50 222
Fax: +49 (0)180 50 50 223
Internet: <http://www.siemens.de/automation/support-request>
- in America
Tel.: +14232622522
Fax: +14232622289
E-mail: simatic.hotline@sea.siemens.com
- Asia / Pacific region
Tel.: +86 1064 757575
Fax: +86 1064 747474
E-mail: adsupport.asia@siemens.com

Technical specifications

General technical specifications

Table 6- 1 General technical specifications

Temperature class	VDE: H UL: H		
Cooling method	AN: Air cooling by means of natural convection		
Line frequency	47 ... 63 Hz		
Standards	IEEE 519-1992		
Paint finish	RAL 7035		
Ambient conditions	Storage	Transport	During operation
Ambient temperature	-25 ... +70 °C	-25 ... +70 °C	0 ... +50 °C
Relative humidity (non-condensing) Corresponds to class:	5 ... 95 % 1K4 to EN 60721-3-1	5 ... 95 % at 40 °C 2K3 to EN 60721-3-2	5 ... 95 % 3K3 to EN 60721-3-3
Mechanical stability	Storage	Transport	During operation
Vibrational load: - Displacement - Acceleration	1.5 mm at 5 ... 9 Hz 5 m/s ² at >9 ... 200 Hz	3.5 mm at 5 ... 9 Hz 10 m/s ² at >9 ... 200 Hz	0.075 mm at 10 ... 58 Hz 10 m/s ² at >58 ... 200 Hz
Shock load: - Acceleration	40 m/s ² at 22 ms	100 m/s ² at 11 ms	100 m/s ² at 11 ms

Detailed technical specifications

Table 6- 2 Line Harmonics Filter, 380 V – 480 V

Category	Unit			
Order number: 6SL3000-		0JE36-1AA0	0JE38-4AA0	0JE41-0AA0
Rated power	kW	315	450	560
Rated voltage - can be rewired to:	V	380 V to 415 V 3 AC $\pm 10\%$ at 50 Hz 440 V to 480 V 3 AC $\pm 10\%$ at 60 Hz		
Rated current	A	500	700	900
Power loss	kW	1.0	1.5	2.0
Connection cross-sections				
Maximum: DIN VDE	mm ²	4 x 240	4 x 240	4 x 240
Mounting holes	mm	15 (2 holes)	15 (2 holes)	15 (2 holes)
Protective conductor connection				
Securing bolt		M12 (3 bolts)	M12 (3 bolts)	M12 (3 bolts)
Weight	kg	460	600	900
Dimensions (W x H x D)	mm	600 x 1700 x 540	800 x 1700 x 540	1000 x 1700 x 540

Table 6- 3 Line Harmonics Filter, 500 V – 690 V, part 1

Category	Unit			
Order number: 6SL3000-		0JH33-3AA0	0JH34-7AA0	0JH35-8AA0
Rated power	kW	315	450	560
Rated voltage - can be rewired to:	V	500 V to 690 V 3 AC $\pm 10\%$ at 50 Hz 500 V to 690 V 3 AC $\pm 10\%$ at 60 Hz		
Rated current	A	290	400	520
Power loss	kW	0.8	1.0	1.5
Connection cross-sections				
Maximum: DIN VDE	mm ²	4 x 240	4 x 240	4 x 240
Mounting holes	mm	15 (2 holes)	15 (2 holes)	15 (2 holes)
Protective conductor connection				
Securing bolt		M12 (3 bolts)	M12 (3 bolts)	M12 (3 bolts)
Weight	kg	450	600	830
Dimensions (W x H x D)	mm	600 x 1700 x 540	800 x 1700 x 540	1000 x 1700 x 540

Table 6- 4 Line Harmonics Filter, 500 V – 690 V, part 2

Category	Unit			
Order number: 6SL3000-		0JH38-1AA0		
Rated power	kW	800		
Rated voltage - can be rewired to:	V	500 V to 690 V 3 AC ±10% at 50 Hz 500 V to 690 V 3 AC ±10% at 60 Hz		
Rated current	A	710		
Power loss	kW	2.0		
Connection cross-sections				
Maximum: DIN VDE	mm ²	4 x 240		
Mounting holes	mm	15 (2 holes)		
Protective conductor connection				
Securing bolt		M12 (3 bolts)		
Weight	kg	830		
Dimensions (W x H x D)	mm	1000 x 1700 x 540		

Siemens AG
Industry Sector
Drive Technologies
Large Drives
P.O. Box 4743
90025 NUREMBERG
GERMANY

www.siemens.com/automation

Subject to change
© Siemens AG 2008