

PRODUCT NUMBER
SEE TABLE

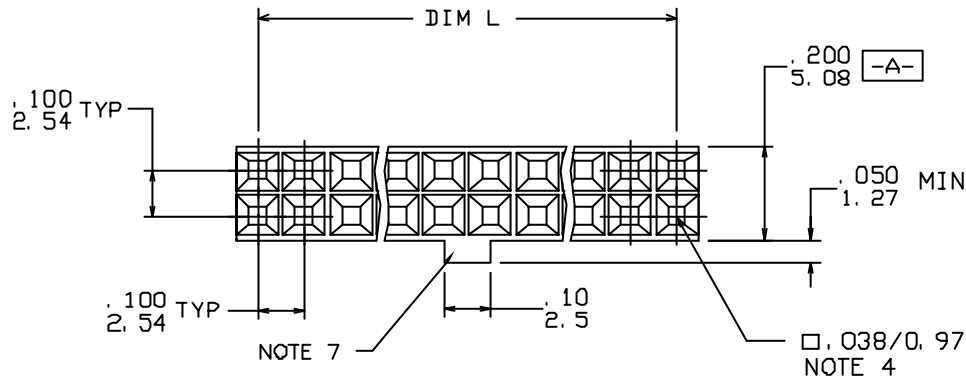
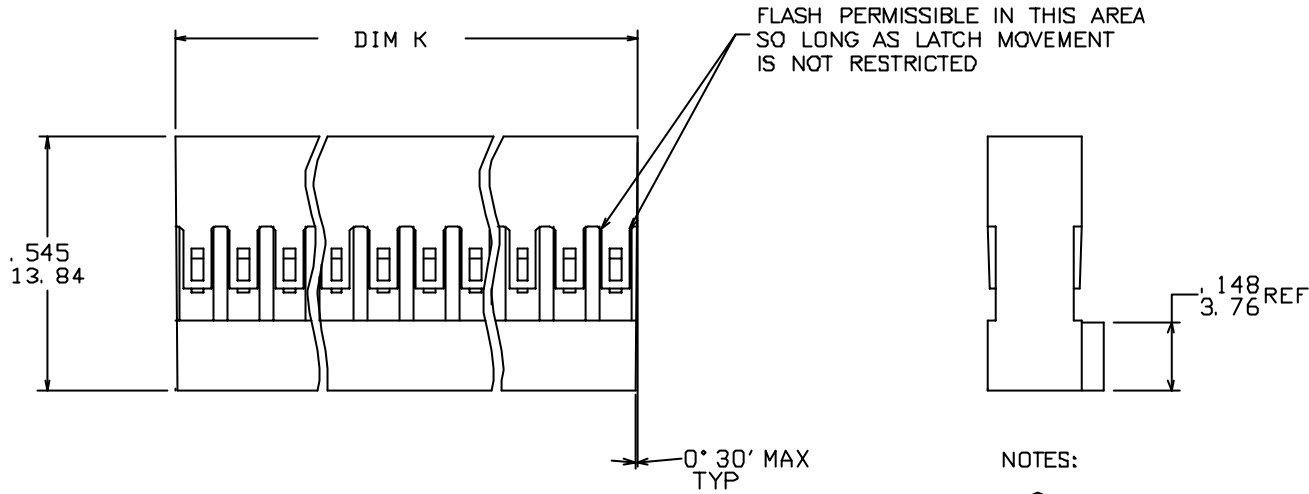

NOTES:

- ① PIN LENGTH RECOMMENDED IS $.225 \pm .015 / 5.72 \pm 0.38$.
- ② MOLDING MATERIAL: MODIFIED POLYPHENYLENE ETHER, FLAME RETARDANT PER UL-94V-0, COLOR: BLACK.
3. SEE TA-75 FOR CRIMPING INSTRUCTIONS. PRODUCT SPECIFICATION: BUS-12-067.
- ④ .003/0.08 MAX FLASH PERMISSIBLE AROUND LEAD IN.
5. PRODUCT MEETS EUROPEAN UNION DIRECTIVES AND OTHER COUNTRY REGULATIONS AS DESCRIBED IN GS-22-008.
6. THIS PRODUCT IS NOT INTENDED TO BE EXPOSED TO MANUFACTURING SOLDER PROCESSES.
- ⑦ CORING CONFIGURATION IN POLARIZING KEY IS MANUFACTURING OPTION.

mat'l. code SEE NOTE 2		surface <input checked="" type="checkbox"/>	tolerance	projection	product family PV HOUSINGS
ltr	ecn no	dr	date	tolerances unless otherwise specified	title
E	V03-1380	PJ	2014-12-13	angles	MINI LATCH HOUSING DR POL.
F	V05-0716	TAB	2105-17-29	linear	.100 [2.54] X .100 [2.54] CC
G	V05-0842	HTB	2005-08-31	0°±2'	scale 3:1
H	V06-0446	HTB	2006-05-16	dr	M. CORNMAN 1990-10-31
J	V07-0533	HTB	2007-08-21	engr	C. TREXLER 1991-08-31
K	F09-0035	LMU	09.06.16	chr	C. TREXLER 1990-10-31
				app	C. TREXLER 1990-10-31
sheet index	revision	K	K		
	sheet	1	2		

PRODUCT NUMBER	NO. OF POS.	DIM K MAX.	DIM L
69176-004LF	2X2	.200/5.08	.100/2.54
69176-006LF	2X3	.300/27.62	.200/5.08
69176-008LF	2X4	.400/10.16	.300/7.62
69176-010LF	2X5	.500/12.70	.400/10.16
69176-012LF	2X6	.600/15.24	.500/12.70
69176-014LF	2X7	.700/17.78	.600/15.24
69176-016LF	2X8	.800/20.32	.700/17.78
69176-018LF	2X9	.900/22.86	.800/20.32
69176-020LF	2X10	1.000/25.40	.900/22.86
69176-022LF	2X11	1.100/27.94	1.000/25.40
69176-024LF	2X12	1.200/30.48	1.100/27.94
69176-026LF	2X13	1.300/33.02	1.200/30.48
69176-028LF	2X14	1.400/35.56	1.300/33.02
69176-030LF	2X15	1.500/38.10	1.400/35.56
69176-032LF	2X16	1.600/40.64	1.500/38.10
69176-034LF	2X17	1.700/43.18	1.600/40.64
69176-036LF	2X18	1.800/45.72	1.700/43.18
69176-038LF	2X19	1.900/48.26	1.800/45.72
69176-040LF	2X20	2.000/50.80	1.900/48.26
69176-042LF	2X21	2.100/53.34	2.000/50.80
69176-044LF	2X22	2.200/55.88	2.100/53.34
69176-046LF	2X23	2.300/58.42	2.200/55.88
69176-048LF	2X24	2.400/60.96	2.300/58.42
69176-050LF	2X25	2.500/63.50	2.400/60.96
69176-052LF	2X26	2.600/66.04	2.500/63.50

PRODUCT NUMBER	NO. OF POS.	DIM K MAX.	DIM L
69176-054LF	2X27	2.700/68.58	2.600/66.04
69176-056LF	2X28	2.800/71.12	2.700/68.58
69176-058LF	2X29	2.900/73.66	2.800/71.12
69176-060LF	2X30	3.000/76.20	2.900/73.66
69176-062LF	2X31	3.100/78.74	3.000/76.20
69176-064LF	2X32	3.200/81.28	3.100/78.74
69176-066LF	2X33	3.300/83.82	3.200/81.28
69176-068LF	2X34	3.400/86.36	3.300/83.82
69176-070LF	2X35	3.500/88.90	3.400/86.36
69176-072LF	2X36	3.600/91.44	3.500/88.90



FCconnect.com

Copyright FCJ

mat'l. code SEE NOTE 2		surface <input checked="" type="checkbox"/>		tolerance		projection		product family PV HOUSINGS	
ltr	ecr no	dr	date	tolerances unless otherwise specified					
K	FDB-0055	LMU	06.08.16	angles	linear			title	
				0°±2'		INCH/MM		MINI LATCH HOUSING DR POL.	
						scale 3:1		.100 [2.54] X .100 [2.54]CC	
		dr	M. CORNMAN	1990-08-31			dwg no		sheet 2 of 2
		engr	C. TREXLER	1991-08-31			69176		A3
		chr	C. TREXLER	1990-08-31			type		Product Customer Drawing
		app	C. TREXLER	1990-08-31					
sheet index	revision sheet								