

6753 Low Pressure Airswitches

PRODUCT IMAGE

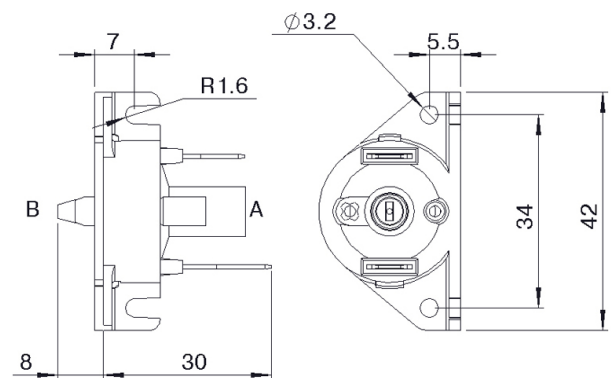

LINE DRAWING



BENEFITS

- sensitive versatile switch, ideal for long tube lengths
- ideal for switching low power circuits
- temperature compensation versions available
- easily adjustable settings

SPECIFICATIONS

standards/approvals	UL 508 specific models only
degree of protection	n/a
connection method	via back entry spout, 4mm dia.
electrical rating	0.5A 250V AC
contact configuration	SPST, N/O or N/C
pressure range	n/a
operating temperature	-5 ⁰ C to +40 ⁰ C
body material	thermoplastic
weight	0.01Kg
additional information	

6753

Low Pressure Airswitches

6753 - -

Contact Configuration

- A SPST N/O
- B SPST N/C

Temperature Compensation Adjuster

- A A Side only
- B B Side only
- C Both Sides
- E No Option Chosen

Temperature Compensation Setting

- A 100 - 300 cc/min Factory Setting (at 345 mbar flow)
- J No Option Chosen

Pressure Setting (mbar)

- | | |
|--------------|--------------|
| A 5.6 ± 22% | F 20.0 ± 10% |
| B 5.0 ± 25% | G 25.0 ± 10% |
| C 7.5 ± 16% | H 30.0 ± 10% |
| D 10.0 ± 12% | J 35.0 ± 10% |

Packaging Options

- A Vacuum Form Tray
(100 off volumes—ideal for OEM applications)
- B Poly Bag

6753

Low Pressure Airswitches

technical data	
body withstand pressure (mbar)	1,000
pressure connection	4mm dia. spout
	pressure or vacuum spout side varies according to contact configuration
connecting tube reference	2311-08 or 2311-01 to suit 4mm dia.
diaphragm	neoprene
mechanical life	1 x 10 ⁶ cycles

electrical data	
contact configuration	SPST N/O or N/C
contact plating	gold over silver
contact rating maximum	0.5A 250V AC
dry switching minimum current	5mA 4V DC
contact resistance	0.05 Ohms

6753 Low Pressure Airswitches

The 6753 range of switches provide a high specification in a small, versatile body shell. Great care has been taken in the switch unit design keeping the moving mass and therefore inertia to a minimum. This means that it can operate at a high cycle rate with low pressure or vacuum.

When measuring pressure pulses such as on component counting applications, the switch will operate very rapidly due to the low inertia of the moving parts and the low swept volume.

For good repeatable switching, the contacts are gold plated on solid silver. The operating pressure will have a direct effect on the contact pressure; therefore at very low pressures the maximum contact rating will not be achieved.

For a normally open switch the contacts can be closed either by applying pressure at port B or vacuum at port A. For a normally closed switch, the contacts can be opened either by applying pressure at port A or vacuum at port B.

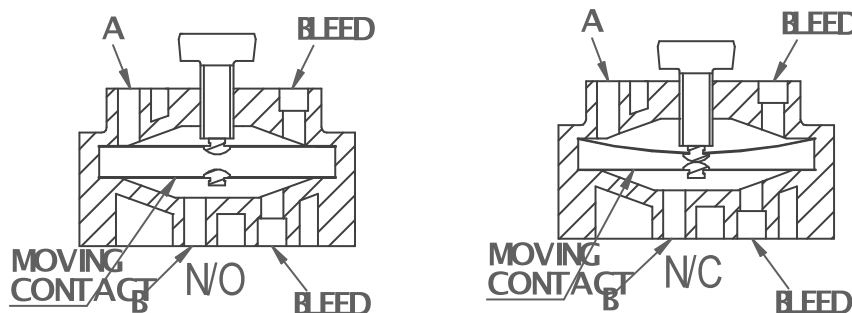

Where temperature compensation is required, consider carefully which side of the moving contact the bleed should be fitted. This will vary dependant on pressure or vacuum operation.