

# R-Rated medium voltage fuses for motor circuit protection



### Features and benefits

- Current-limiting R-Rated fuses will safely interrupt all currents between their minimum and maximum interrupting ratings and will melt in a range of 15 to 35 seconds at a value of 100 times the “R” number per ANSI C37.46.
- R-Rated fuses are physically dimensioned for easy installation in existing hardware.
- Available in standard, AMPGARD Hookeye and hermetically sealed, and bolt-on mounting styles to meet application needs.
- 2.4kV and 4.8kV AMPGARD hermetically sealed constructions are suitable for Class I, Group D, Div. 2 hazardous locations.
- Open fuse indicator on all mounting styles speeds troubleshooting.
- Optional remote contact signaling microswitch available.
- Classified as backup fuses for current-limiting protection of medium voltage motor controllers (short-circuit performance only).
- These fuses are in a self-contained, non-venting package for installation indoors or outdoors in an enclosure.

### Description:

- Indoor/enclosure, R-Rated medium voltage, current-limiting fuses for motor circuit protection.

### Typical applications:

- Medium voltage motors and controllers

### Contents

| Description                      | Page        | Description                      | Page         |
|----------------------------------|-------------|----------------------------------|--------------|
| <b>2.4kV R-Rated fuses</b> ..... | <b>2-7</b>  | <b>7.2kV R-Rated fuses</b> ..... | <b>17-21</b> |
| Introduction .....               | 2           | Introduction .....               | 17           |
| Catalog numbers .....            | 3           | Catalog numbers .....            | 18           |
| Curves .....                     | 4-7         | Curves .....                     | 19-21        |
| <b>4.8kV R-Rated fuses</b> ..... | <b>8-16</b> |                                  |              |
| Introduction .....               | 8           |                                  |              |
| Catalog numbers .....            | 9           |                                  |              |
| Curves .....                     | 10-16       |                                  |              |

**2.4kV R-Rated fuses**

**Catalog symbols:**

| Code-(amps)R | Construction                                      |
|--------------|---|
| 2CLS-25      | Standard (25A only)                               |
| 2ACLS-25     | AMPGARD Hookeye (25A only)                        |
| JCK-R        | Standard (2R-24R)                                 |
| JCK-A-R      | AMPGARD Hookeye* (2R-24R)                         |
| 2HCLS-R      | Hermetically sealed AMPGARD Hookeye* (25A/2R-24R) |
| 2BCLS-R      | Bolt-on (25A/2R-24R)                              |

\* For use in 400 amp AMPGARD motor starters.

**Ratings:**

- Volts
  - 2.4kV (nominal)
  - 2.54kV (max design)
- Amps 25-450A
- Interrupting ratings
  - 50kA Sym
  - 80kA Asym

**Agency information:**

- UL Recognized: Guide #MSSS2, File #E96676

**Recommended fuse holders for standard constructions:**

| Amp range                 | Description                            | Cat. No.   |
|---------------------------|--|------------|
| <b>Fuseclips</b>          |  |            |
| 25-230A                   | 3" Enclosed fuseclip*                  | A3354730   |
| 25-450A                   | 3" Open fuseclip                       | 1A0065     |
|                           | 3" Spring loaded open fuseclip         | 9078A67G04 |
| <b>Fuse holders</b>       |  |            |
| 25-230A<br>Single barrel  | Non-disconnect holder, porcelain       | 2CLE-PNM-D |
|                           | Non-disconnect holder, glass polyester | 2CLE-GNM-D |
|                           | Disconnect holder, porcelain           | 2CLE-PDM-D |
|                           | Disconnect holder, glass polyester     | 2CLE-GDM-E |
| 390-450A<br>Double barrel | Non-disconnect holder, porcelain       | 2CLE-PNM-E |
|                           | Non-disconnect holder, glass polyester | 2CLE-GNM-E |
|                           | Disconnect holder, porcelain           | 2CLE-PDM-E |
|                           | Disconnect holder, glass polyester     | 2CLE-GDM-E |

\* Single barrel only, not sold in pairs.

**Dimensions - in [mm]**

| Construction     | Amp range | Dimension  |            |        |          |
|------------------|-----------|------------|------------|--------|----------|
|                  |           | A          | B          | C      | D        |
| Standard - short | 25-230A   | 10.8 (274) | 3 (76)     | 3 (76) | —        |
|                  | 390-450A  | 10.8 (274) | 3 (76)     | 3 (76) | 3.3 (84) |
| AMPGARD Hookeye* | 70-230A   | 10.8 (274) | 3 (76)     | 3 (76) | —        |
|                  | 390-450A  | 10.8 (274) | 3 (76)     | 3 (76) | 3.3 (84) |
| Bolt-on          | 25-230A   | 19.2 (488) | 17.9 (455) | 3 (76) | —        |
|                  | 390-450A  | 19.2 (488) | 17.9 (455) | 3 (76) | 3.3 (84) |

\* Includes hermetically sealed versions.

**Standard and AMPGARD Hookeye**

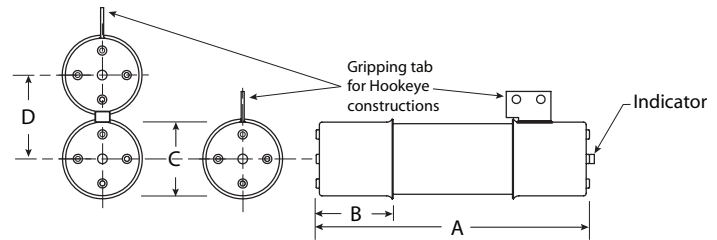

**Bolt-on**

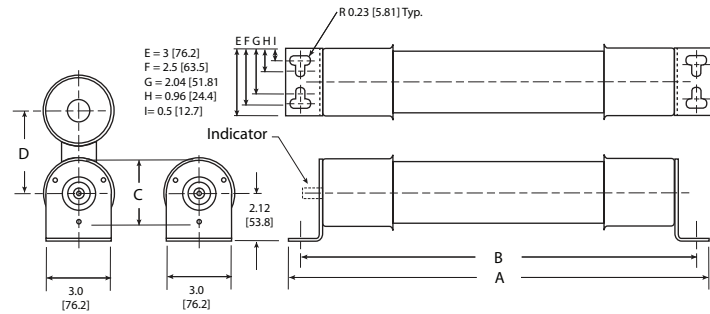

2.4kV R-Rated fuse catalog numbers

| Amp rating | "R"<br>Designation | Mounting style (minimum interrupting rating in amps) |                  |                     |                  | Number<br>of barrels |
|------------|--------------------|--|------------------|---------------------|------------------|----------------------|
|            |                    | Standard   | AMPGARD Hookeye  |                     |                  |                      |
|            |                    |  | Regular          | Hermetically sealed | Bolt-on          |                      |
| 25         | —                  | 2CLS-25* (90)  | 2ACLS-25* (90)   | 2HCLS-25* (90)      | 2BCLS-25* (90)   | 1                    |
| 70         | 2R                 | JCK-2R (165)   | JCK-A-2R (165)   | 2HCLS-2R (170)      | 2BCLS-2R (170)   | 1                    |
| 100        | 3R                 | JCK-3R (220)   | JCK-A-3R (220)   | 2HCLS-3R (245)      | 2BCLS-3R (245)   | 1                    |
| 130        | 4R                 | JCK-4R (320)   | JCK-A-4R (320)   | 2HCLS-4R (340)      | 2BCLS-4R (340)   | 1                    |
| 150        | 5R                 | JCK-5R (410)   | JCK-A-5R (410)   | 2HCLS-5R (430)      | 2BCLS-5R (430)   | 1                    |
| 170        | 6R                 | JCK-6R (480)   | JCK-A-6R (480)   | 2HCLS-6R (500)      | 2BCLS-6R (500)   | 1                    |
| 200        | 9R                 | JCK-9R (720)   | JCK-A-9R (720)   | 2HCLS-200* (1000)   | 2BCLS-9R (1000)  | 1                    |
| 230        | 12R                | JCK-12R (970)  | JCK-A-12R (970)  | 2HCLS-230* (1250)   | 2BCLS-12R (1250) | 1                    |
| 390        | 18R                | JCK-18R (1430)                                       | JCK-A-18R (1430) | 2HCLS-390* (1700)   | 2BCLS-18R (1700) | 2                    |
| 450        | 24R                | JCK-24R (1880)                                       | JCK-A-24R (1880) | 2HCLS-24R (2100)    | 2BCLS-24R (2100) | 2                    |

\* Does not comply with ANSI C37.46 for "R" rating.

JCK and 2HCLS Type mountings -in (mm)

| Catalog<br>number                   | Hole centers |           | Overall<br>length<br>C | Hole Inset<br>D | Hole centers<br>E | Contact<br>height<br>F | Overall<br>height<br>G | BIL<br>rating<br>(kV) |
|-------------------------------------|--------------|-----------|------------------------|-----------------|-------------------|------------------------|------------------------|-----------------------|
|                                     | A            | B         |                        |                 |                   |                        |                        |                       |
| <b>Disconnect single barrel†</b>    |              |           |                        |                 |                   |                        |                        |                       |
| 2CLE-GDM-D                          | 8.24 (209.3) | 6 (152.4) | 18 (457.2)             | 0.62 (15.7)     | 1.75 (44.4)       | 4.5 (114.3)            | 11.72 (297.7)          | 60                    |
| 2CLE-PDM-D                          | 8.24 (209.3) | 6 (152.4) | 18 (457.2)             | 0.62 (15.7)     | 1.75 (44.4)       | 4.5 (114.3)            | 11.72 (297.7)          | 60                    |
| <b>Disconnect double barrel†</b>    |              |           |                        |                 |                   |                        |                        |                       |
| 2CLE-GDM-E                          | 8.24 (209.3) | 6 (152.4) | 18 (457.2)             | 0.62 (15.7)     | 1.75 (44.4)       | 4.5 (114.3)            | 15.28 (388.1)          | 60                    |
| 2CLE-PDM-E                          | 8.24 (209.3) | 6 (152.4) | 18 (457.2)             | 0.62 (15.7)     | 1.75 (44.4)       | 4.5 (114.3)            | 15.28 (388.1)          | 60                    |
| <b>Non-disconnect single barrel</b> |              |           |                        |                 |                   |                        |                        |                       |
| 2CLE-GNM-D                          | 8.24 (209.3) | 6 (152.4) | 18 (457.2)             | 0.62 (15.7)     | 1.75 (44.4)       | 4.5 (114.3)            | 8.79 (223.3)           | 60                    |
| 2CLE-PNM-D                          | 8.24 (209.3) | 6 (152.4) | 18 (457.2)             | 0.62 (15.7)     | 1.75 (44.4)       | 4.5 (114.3)            | 8.79 (223.3)           | 60                    |
| <b>Non-disconnect double barrel</b> |              |           |                        |                 |                   |                        |                        |                       |
| 2CLE-GNM-E                          | 8.24 (209.3) | 6 (152.4) | 18 (457.2)             | 0.62 (15.7)     | 1.75 (44.4)       | 4.5 (114.3)            | 12.48 (317.0)          | 60                    |
| 2CLE-PNM-E                          | 8.24 (209.3) | 6 (152.4) | 18 (457.2)             | 0.62 (15.7)     | 1.75 (44.4)       | 4.5 (114.3)            | 12.48 (317.0)          | 60                    |

2.4kV disconnect mounting†

2.4kV non-disconnect mounting

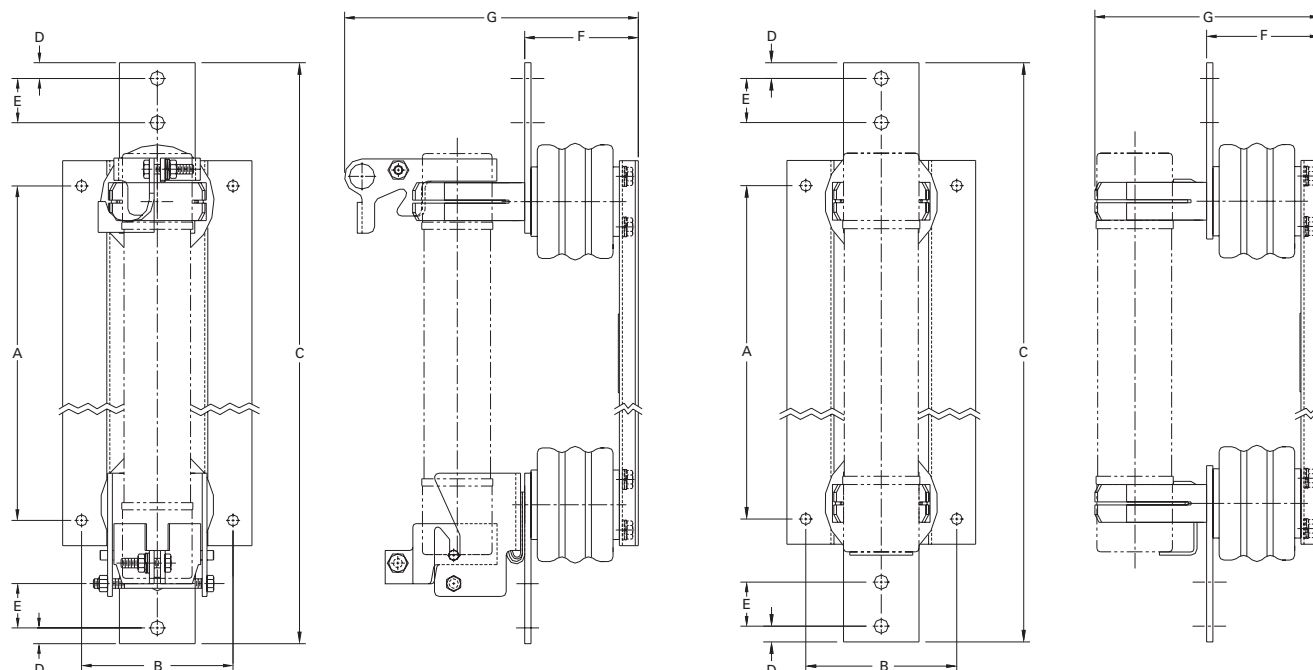

† Disconnect mountings provide a means for fuse extraction only. Do not use a disconnect mounting for load switching or fuse removal while energized.

2.4kV Time-current curves — minimum melting for 2HCLS-<sub>R</sub> and 2BCLS-<sub>R</sub> (25A, 2R-24R @25°C)

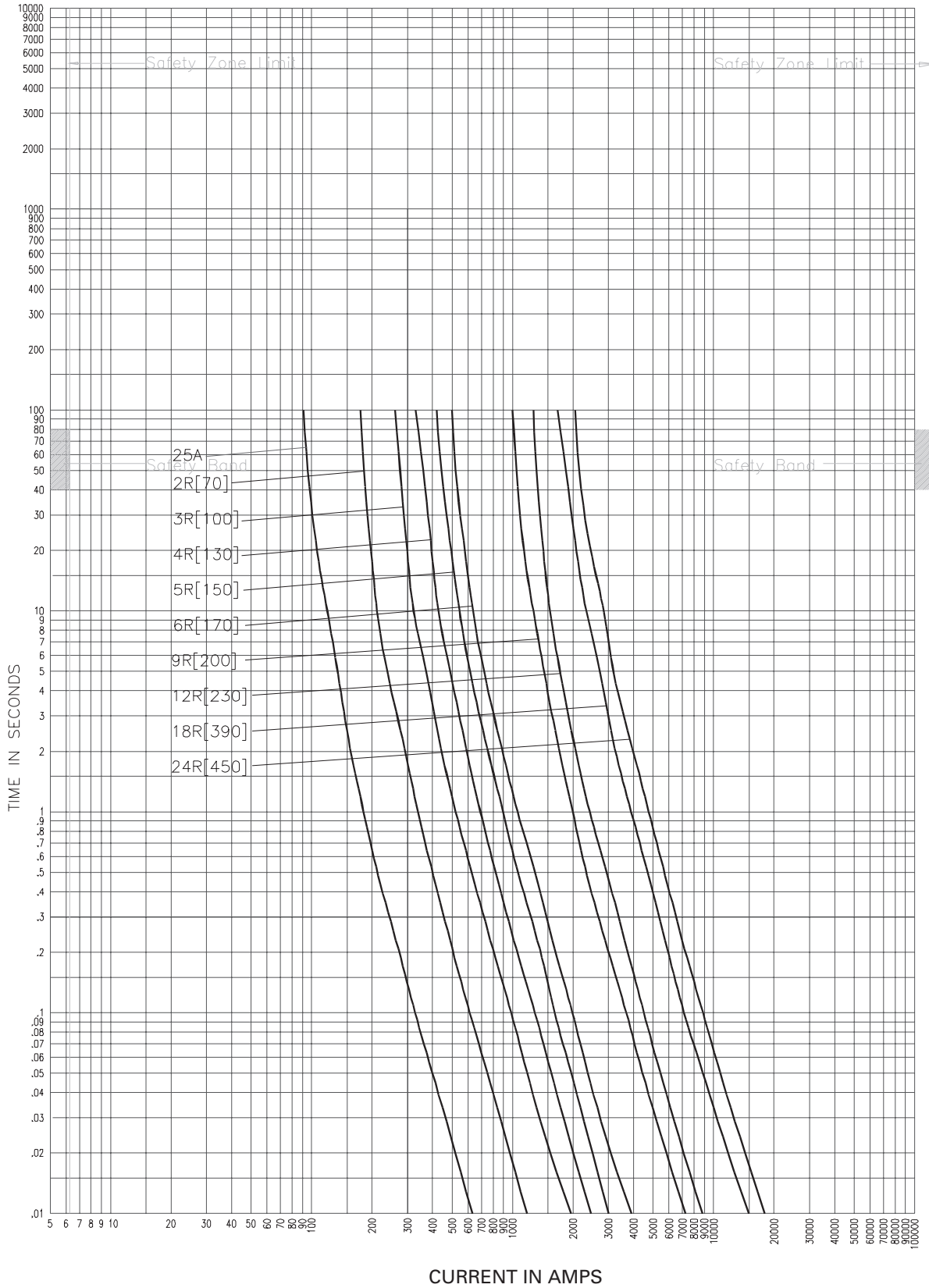

CURVE 66664702  
 January 2001  
 Reference # 666647,  
 512853, 639405

2HCLS-<sub>R</sub> and 2BCLS-<sub>R</sub>

2.4kV Time-current curves — total clearing for 2HCLS-<sub>R</sub> and 2BCLS-<sub>R</sub> (25A, 2R-24R @25°C)

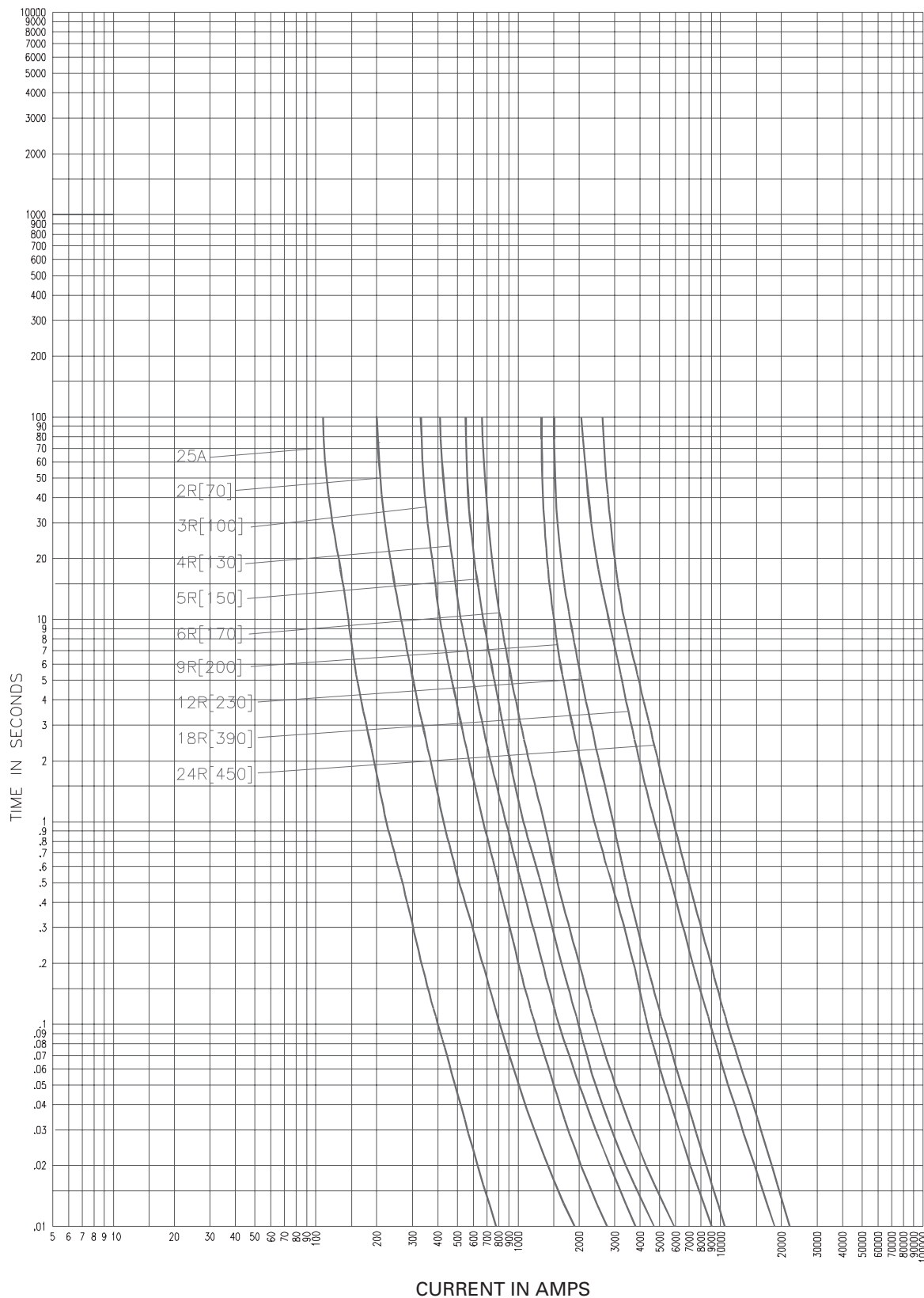

2HCLS-<sub>R</sub> and 2BCLS-<sub>R</sub>

CURVE 66664704  
January 2000  
Reference # 666647,  
512854, 639406

2.4kV Peak let-through curves for 2HCLS-\_R and 2BCLS-\_R (25A, 2R-24R @25°C)

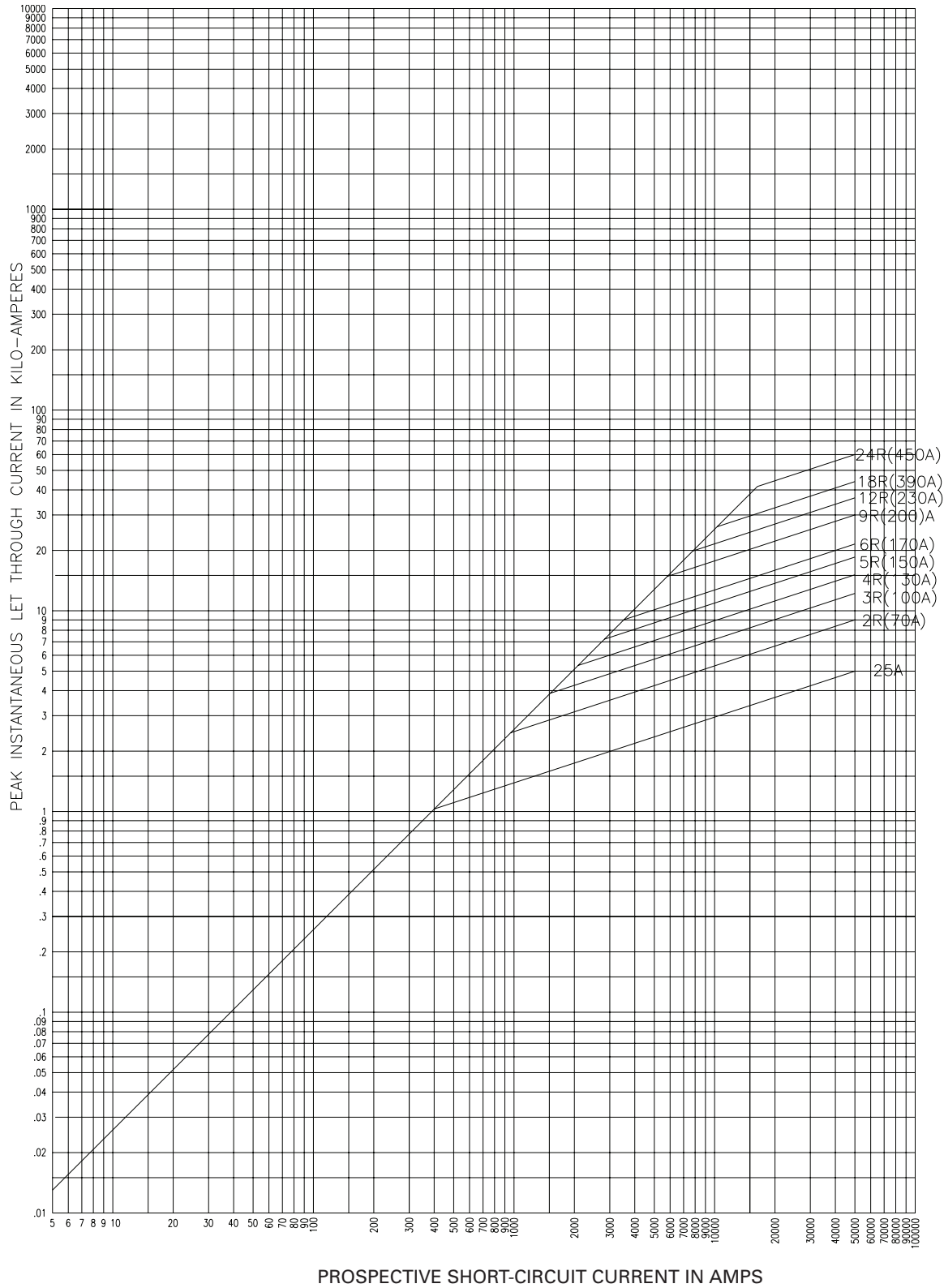

2HCLS-\_R and 2BCLS-\_R

CURVE 66700202  
 January 2001  
 Reference # 639315

2.4kV Time-current curves — minimum melting for JCK-\_R and JCK-A-\_R (2R-24R @25°C)

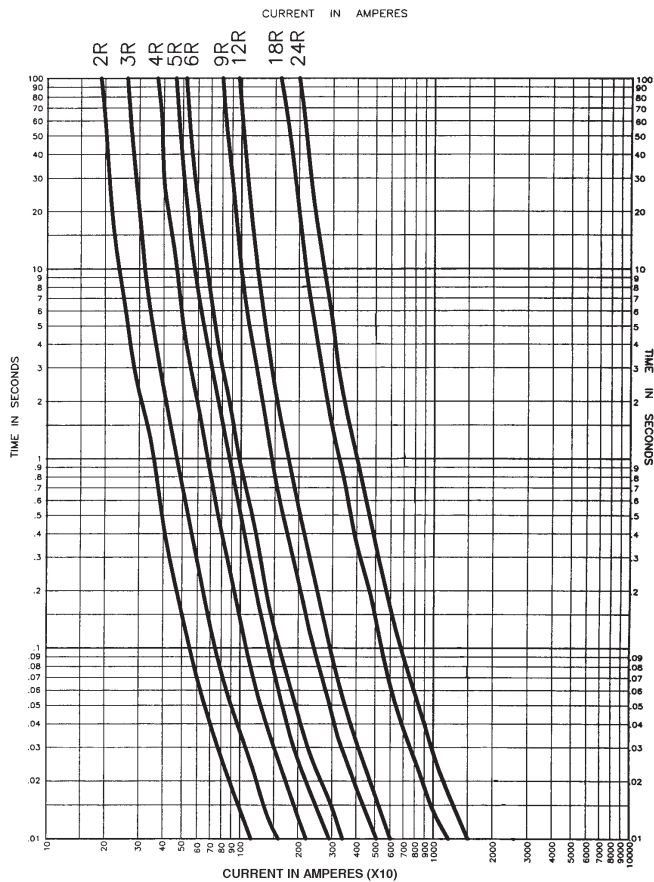

2.4kV Time-current curves — total clearing for JCK-\_R and JCK-A-\_R (2R-24R @25°C)

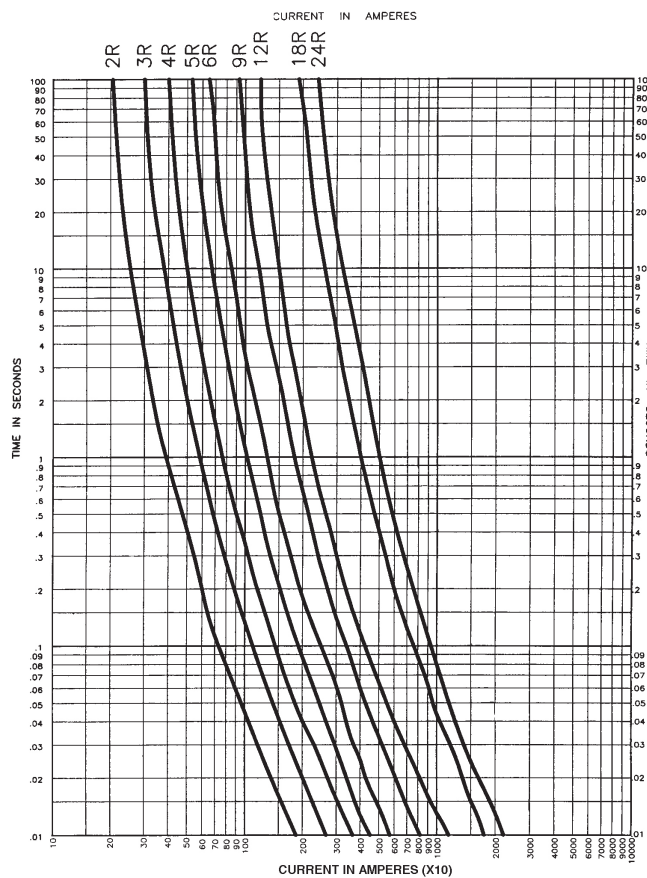

2.4kV Peak let-through curves for JCK-\_R and JCK-A-\_R (2R-24R @25°C)

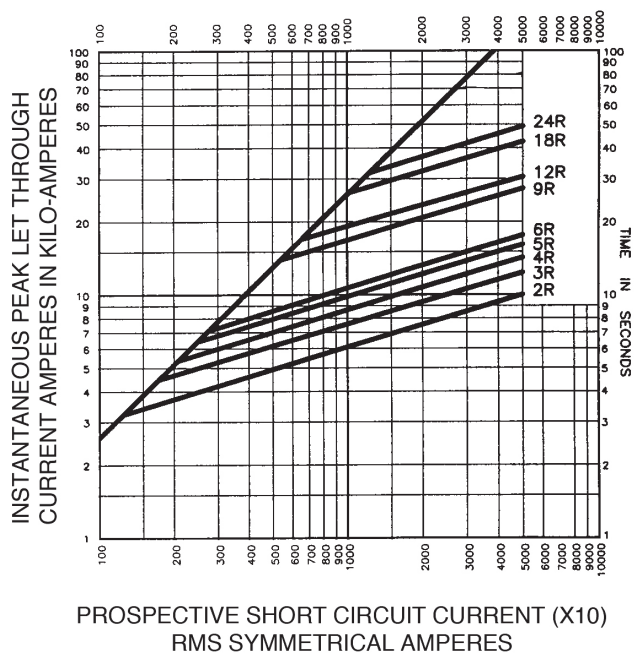

**4.8kV R-Rated fuses**

**Catalog symbols:**

| Code-(amps)R | Construction                                  |
|--------------|---|
| 5CLS-30      | Standard - short (30A)                        |
| JCL-_R       | Standard - short (2R - 24R)                   |
| 5LCLS-_R     | Standard - long (2R - 24R)                    |
| JCL-A-_R     | AMPGARD Hookeye* (2R - 24R)                   |
| 5ACLS-30     | AMPGARD Hookeye* (30A)                        |
| 5HCLS-30     | Hermetically sealed AMPGARD Hookeye* (30A)    |
| 5HCLS-_R     | Hermetically sealed AMPGARD Hookeye* (2R-24R) |
| 5BCLS-30     | Bolt-on (30A)                                 |
| 5BCLS-_R     | Bolt-on (2R - 44R)                            |

\* For use in 400 amp AMPGARD motor starters.

**Ratings:**

- Volts
  - 4.8kV (nominal)
  - 5.08kV (max design)
- Amps 30-450A
- Interrupting ratings
  - 50kA Sym
  - 80kA Asym

**Agency information:**

- UL Recognized: Guide #MSSS2, File #E96676 (JCL-\_R [2R-24R] and JCL-A-\_R [2R-24R])

**Recommended fuse holders for standard constructions:**

| Amp range                                 | Description                            | BIL (kV) | Cat. No.   |
|---|--|----------|------------|
| <b>Fuseclips</b>                          |  |          |            |
| 30-230A                                   | 3" Enclosed fuseclip*                  | —        | A3354730   |
|   | 3" Open fuseclip                       | —        | 1A0065     |
| 30-450A                                   | 3" Spring loaded open fuseclip         | —        | 9078A67G04 |
| <b>Fuse holders for CLS / JCL / 5HCLS</b> |  |          |            |
|   | Non-disconnect holder, porcelain       | 60       | 5HLE-PNM-D |
| 30-230A                                   | Non-disconnect holder, glass polyester | 60       | 5HLE-GNM-D |
| Single barrel                             | Disconnect holder, porcelain           | 60       | 5HLE-PDM-D |
|   | Disconnect holder, glass polyester     | 60       | 5HLE-GDM-D |
|   | Non-disconnect holder, porcelain       | 60       | 5HLE-PNM-E |
| 390-450A                                  | Non-disconnect holder, glass polyester | 60       | 5HLE-GNM-E |
| Double barrel                             | Disconnect holder, porcelain           | 60       | 5HLE-PDM-E |
|   | Disconnect holder, glass polyester     | 60       | 5HLE-GDM-E |
| <b>Fuse holders for 5LCLS†</b>            |  |          |            |
|   | Non-disconnect holder, porcelain       | 60       | 5CLE-PNM-D |
|   | Non-disconnect holder, glass polyester | 60       | 5CLE-GNM-D |
| 70-230A                                   | Disconnect holder, porcelain           | 60       | 5CLE-PDM-D |
| Single barrel                             | Disconnect holder, glass polyester     | 60       | 5CLE-GDM-D |
|   | Disconnect holder, porcelain           | 75       | 8CLE-PDM-D |
|   | Disconnect holder, glass polyester     | 75       | 8CLE-GDM-D |
| 390-450A                                  | Disconnect holder, porcelain           | 60       | 5CLE-PDM-E |
| Double Barrel                             | Disconnect holder, glass polyester     | 60       | 5CLE-GDM-E |

\* Single barrel only, not sold in pairs.  
 \*\* Not available for standard - long constructions  
 † Not available for 390 to 450 amp ratings.

**Dimensions - in [mm]**

| Construction     | Amp range | Dimension  |            |        |          |
|------------------|-----------|------------|------------|--------|----------|
|                  |           | A          | B          | C      | D        |
| Standard - short | 30-230A   | 15.9 (404) | 3 (76)     | 3 (76) | —        |
|                  | 390-450A  | 15.9 (404) | 3 (76)     | 3 (76) | 3.3 (84) |
| Standard - long  | 70-230A   | 17.9 (455) | 3 (76)     | 3 (76) | —        |
|                  | 390-450A  | 17.9 (455) | 3 (76)     | 3 (76) | 3.3 (84) |
| AMPGARD Hookeye* | 30-230A   | 15.9 (404) | 3 (76)     | 3 (76) | —        |
|                  | 390-450A  | 15.9 (404) | 3 (76)     | 3 (76) | 3.3 (84) |
| Bolt-on          | 30-230A   | 19.2 (488) | 17.9 (455) | 3 (76) | —        |
|                  | 390-450A  | 19.2 (488) | 17.9 (455) | 3 (76) | 3.3 (84) |

\* Includes hermetically sealed versions.

**Standard (short and long) and AMPGARD Hookeye**

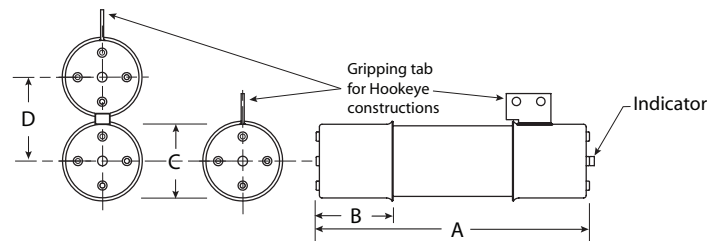

**Bolt-on**

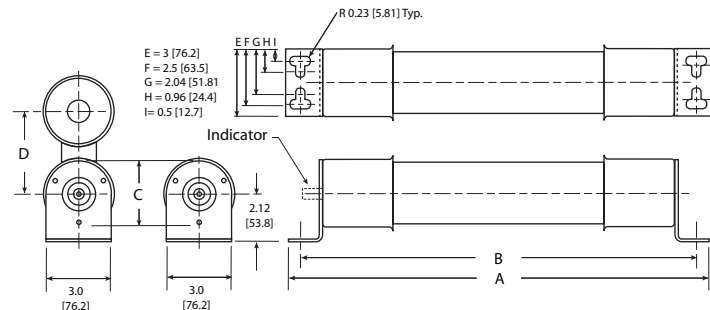

4.8kV R-Rated fuse catalog numbers

| Amp Rating | "R"<br>Designation | Mounting style (minimum interrupting rating in amps) |                  |                 |                     |                  | Number of barrels |
|------------|--------------------|--|------------------|-----------------|---------------------|------------------|-------------------|
|            |                    | Standard - short                                     | Standard - long  | AMPGARD Hookeye |                     |                  |                   |
|            |                    |  |                  | Regular         | Hermetically sealed | Bolt-on          |                   |
| 30         | —                  | 5CLS-30* (95)  | —                | 5ACLS-30* (95)  | 5HCLS-30* (95)      | 5BCLS-30* (95)   | 1                 |
| 70         | 2R                 | JCL-2R (165)   | 5LCLS-2R (165)   | JCL-A-2R        | 5HCLS-2R (180)      | 5BCLS-2R (180)   | 1                 |
| 100        | 3R                 | JCL-3R (220)   | 5LCLS-3R (220)   | JCL-A-3R        | 5HCLS-3R (270)      | 5BCLS-3R (270)   | 1                 |
| 130        | 4R                 | JCL-4R (320)   | 5LCLS-4R (320)   | JCL-A-4R        | 5HCLS-4R (350)      | 5BCLS-4R (350)   | 1                 |
| 150        | 5R                 | JCL-5R (410)   | 5LCLS-5R (410)   | JCL-A-5R        | 5HCLS-5R (450)      | 5BCLS-5R (450)   | 1                 |
| 170        | 6R                 | JCL-6R (480)   | 5LCLS-6R (480)   | JCL-A-6R        | 5HCLS-6R (540)      | 5BCLS-6R (540)   | 1                 |
| 200        | 9R                 | JCL-9R (720)   | 5LCLS-9R (720)   | JCL-A-9R        | 5HCLS-9R (700)      | 5BCLS-9R (700)   | 1                 |
| 230        | 12R                | JCL-12R (970)  | 5LCLS-12R (970)  | JCL-A-12R       | 5HCLS-12R (1000)    | 5BCLS-12R (1000) | 1                 |
| 390        | 18R                | JCL-18R (1430)                                       | 5LCLS-18R (1430) | JCL-A-18R       | 5HCLS-18R (1450)    | 5BCLS-18R (1450) | 2                 |
| 450        | 24R                | JCL-24R (1880)                                       | 5LCLS-24R (1880) | JCL-A-24R       | 5HCLS-24R (2000)    | 5BCLS-24R (2000) | 2                 |
| 600        | 32R                | —  | —                | —               | —                   | 5BCLS-32R (2600) | 2                 |
| 650        | 36R                | —  | —                | —               | —                   | 5BCLS-36R (3000) | 2                 |
| 800        | 44R                | —  | —                | —               | —                   | 5BCLS-44R (3250) | 2                 |

\* Does not comply with ANSI C37.46 for "R" rating.

5CLS, JCL, JCL-A, 5ACLS, 5HCLS and 5LCLS Type mountings - in (mm)

| Catalog number                      | Hole centers  |           | Overall length | Hole Inset  | Hole centers | Contact height | Overall height | BIL rating (kV) |
|-------------------------------------|---------------|-----------|----------------|-------------|--------------|----------------|----------------|-----------------|
|                                     | A             | B         | C              | D           | E            | F              | G              |                 |
| <b>Disconnect single barrel†</b>    |               |           |                |             |              |                |                |                 |
| 5CLE-GDM-D                          | 15.24 (387.1) | 6 (152.4) | 25 (647.7)     | 0.62 (15.7) | 1.75 (44.4)  | 4.5 (114.3)    | 11.72 (297.7)  | 60              |
| 5CLE-PDM-D                          | 15.24 (387.1) | 6 (152.4) | 25 (647.7)     | 0.62 (15.7) | 1.75 (44.4)  | 4.5 (114.3)    | 11.72 (297.7)  | 60              |
| 5HLE-PDM-D                          | 16.25 (412.8) | 6 (152.4) | 23 (584.2)     | 0.62 (15.7) | 1.75 (44.4)  | 4.5 (114.3)    | 11.72 (297.7)  | 60              |
| 5HLE-GDM-D                          | 16.25 (412.8) | 6 (152.4) | 23 (584.2)     | 0.62 (15.7) | 1.75 (44.4)  | 4.5 (114.3)    | 11.72 (297.7)  | 60              |
| <b>Disconnect double barrel†</b>    |               |           |                |             |              |                |                |                 |
| 5CLE-GDM-E                          | 15.24 (387.1) | 6 (152.4) | 25 (647.7)     | 0.62 (15.7) | 1.75 (44.4)  | 4.5 (114.3)    | 15.28 (388.1)  | 60              |
| 5CLE-PDM-E                          | 15.24 (387.1) | 6 (152.4) | 25 (647.7)     | 0.62 (15.7) | 1.75 (44.4)  | 4.5 (114.3)    | 15.28 (388.1)  | 60              |
| 5HLE-GDM-E                          | 16.25 (412.8) | 6 (152.4) | 23 (584.2)     | 0.62 (15.7) | 1.75 (44.4)  | 4.5 (114.3)    | 15.28 (388.1)  | 60              |
| 5HLE-PDM-E                          | 16.25 (412.8) | 6 (152.4) | 23 (584.2)     | 0.62 (15.7) | 1.75 (44.4)  | 4.5 (114.3)    | 15.28 (388.1)  | 60              |
| <b>Non-disconnect single barrel</b> |               |           |                |             |              |                |                |                 |
| 5CLE-GNM-D                          | 15.24 (387.1) | 6 (152.4) | 25 (635.0)     | 0.62 (15.7) | 1.75 (44.4)  | 4.5 (114.3)    | 8.79 (223.3)   | 60              |
| 5CLE-PNM-D                          | 15.24 (387.1) | 6 (152.4) | 25 (635.0)     | 0.62 (15.7) | 1.75 (44.4)  | 4.5 (114.3)    | 8.79 (223.3)   | 60              |
| 5HLE-GNM-D                          | 16.25 (412.7) | 6 (152.4) | 23 (584.2)     | 0.62 (15.7) | 1.75 (44.4)  | 4.5 (114.3)    | 8.79 (223.3)   | 60              |
| 5HLE-PNM-D                          | 16.25 (412.7) | 6 (152.4) | 23 (584.2)     | 0.62 (15.7) | 1.75 (44.4)  | 4.5 (114.3)    | 8.79 (223.3)   | 60              |
| <b>Non-disconnect double barrel</b> |               |           |                |             |              |                |                |                 |
| 5HLE-PNM-E                          | 16.25 (412.7) | 6 (152.4) | 25 (635.0)     | 0.62 (15.7) | 1.75 (44.4)  | 4.5 (114.3)    | 12.48 (317.0)  | 60              |
| 5HLE-GNM-E                          | 16.25 (412.7) | 6 (152.4) | 25 (635.0)     | 0.62 (15.7) | 1.75 (44.4)  | 4.5 (114.3)    | 12.48 (317.0)  | 60              |

4.8kV disconnect mounting†

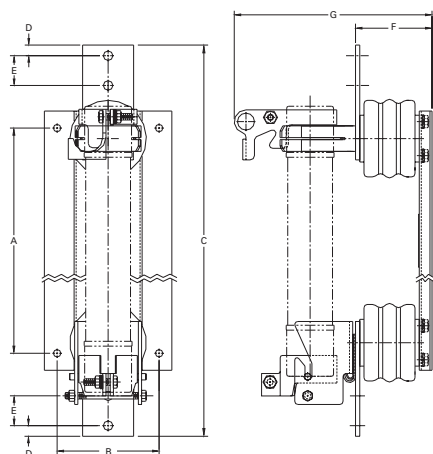

4.8kV non-disconnect mounting

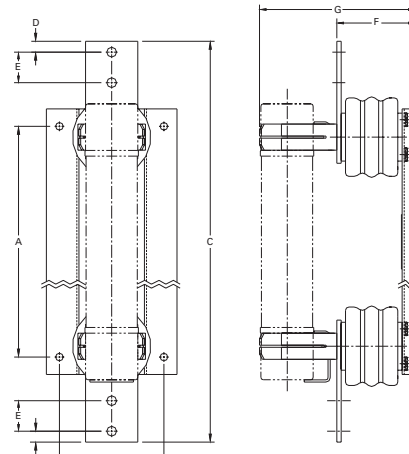

† Disconnect mountings provide a means for fuse extraction only. Do not use a disconnect mounting for load switching or fuse removal while energized.

**4.8kV Time-current curves — minimum melting for 5ACLS-30, 5CLS-30, 5HCLS-<sub>R</sub>, 5BCLS-30 and 5BCLS-<sub>R</sub> (30A, 2R-24R @ 25°C)**

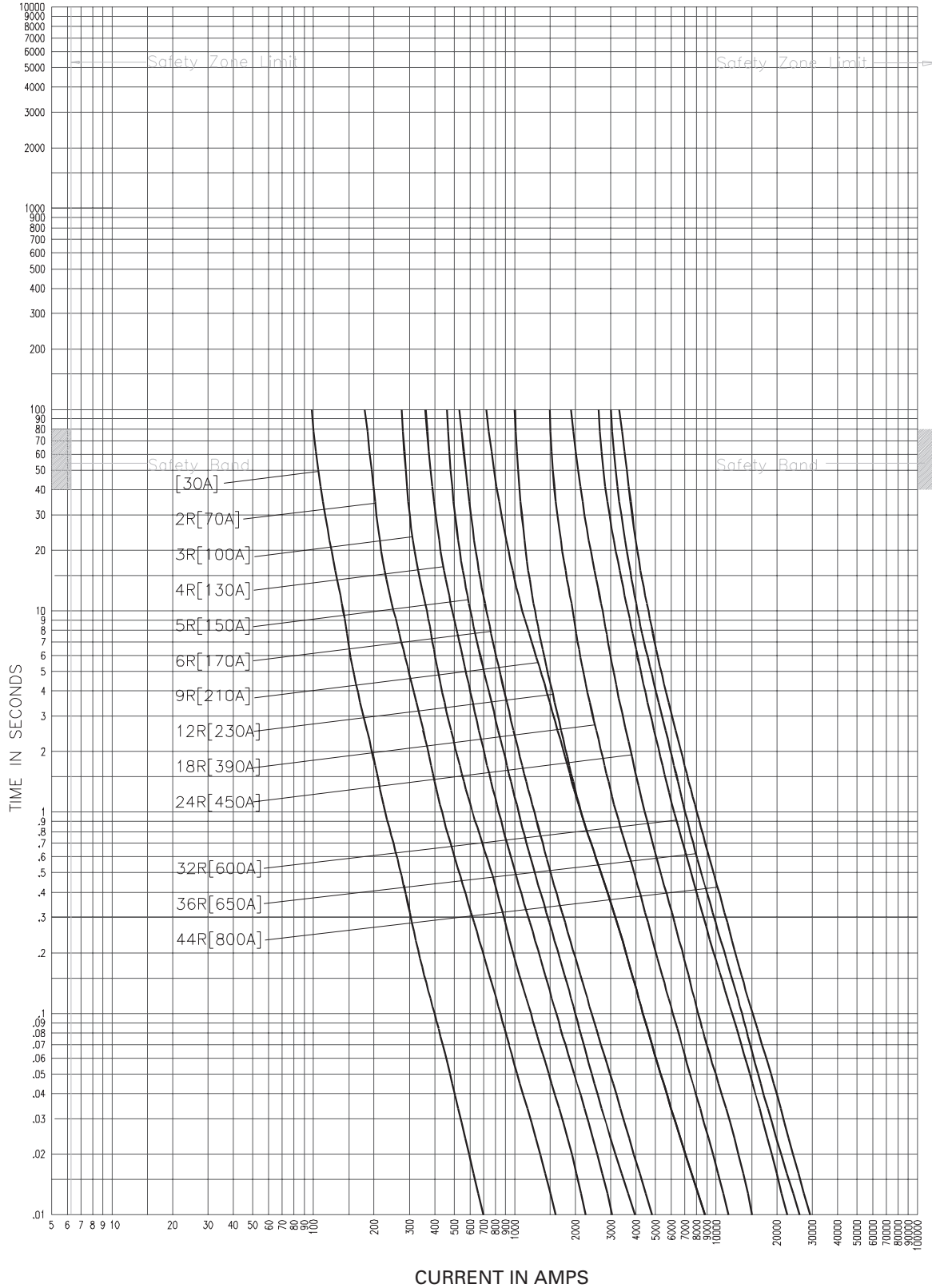

**5ACLS-30, 5CLS-30, 5HCLS-<sub>R</sub>, 5BCLS-30, 5BCLS-<sub>R</sub>**

CURVE 66690602  
 January 2001  
 Reference # 666907,  
 666703, 666910,  
 667000, 639472.

4.8kV Time-current curves — total clearing for 5ACLS-30, 5CLS-30, 5HCLS-R, 5BCLS-30 and 5BCLS-R (30A, 2R-24R @ 25°C)

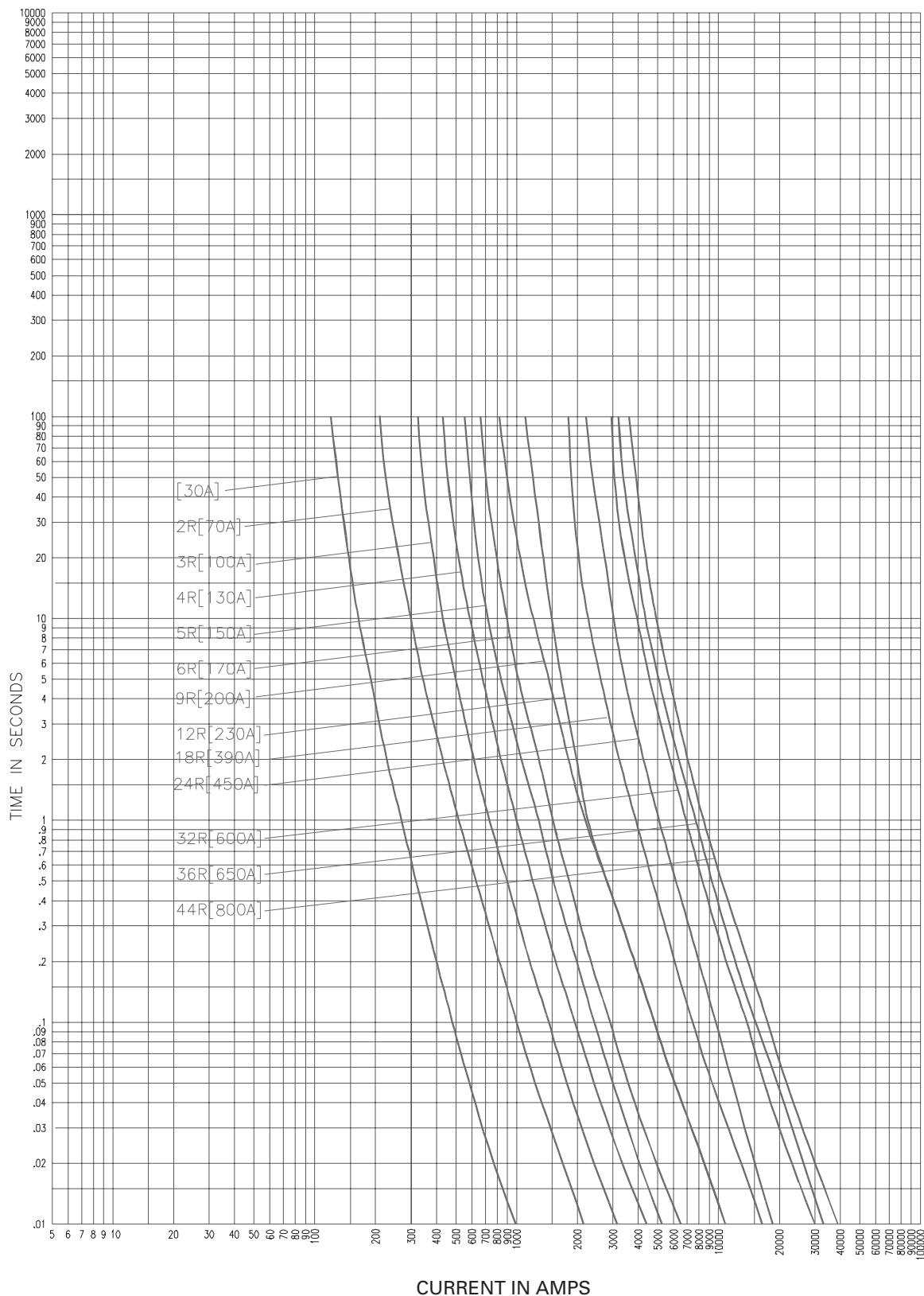

5ACLS-30, 5CLS-30, 5HCLS-R, 5BCLS-30, 5BCLS-R

CURVE 66690702  
January 2001  
Reference # 666907  
666704, 666910,  
6670001, 639472.

4.8kV Peak let-through curves for 5ACLS-30, 5CLS-30, 5HCLS-<sub>R</sub>, 5BCLS-30 and 5BCLS-<sub>R</sub> (30A, 2R-24R @ 25°C)

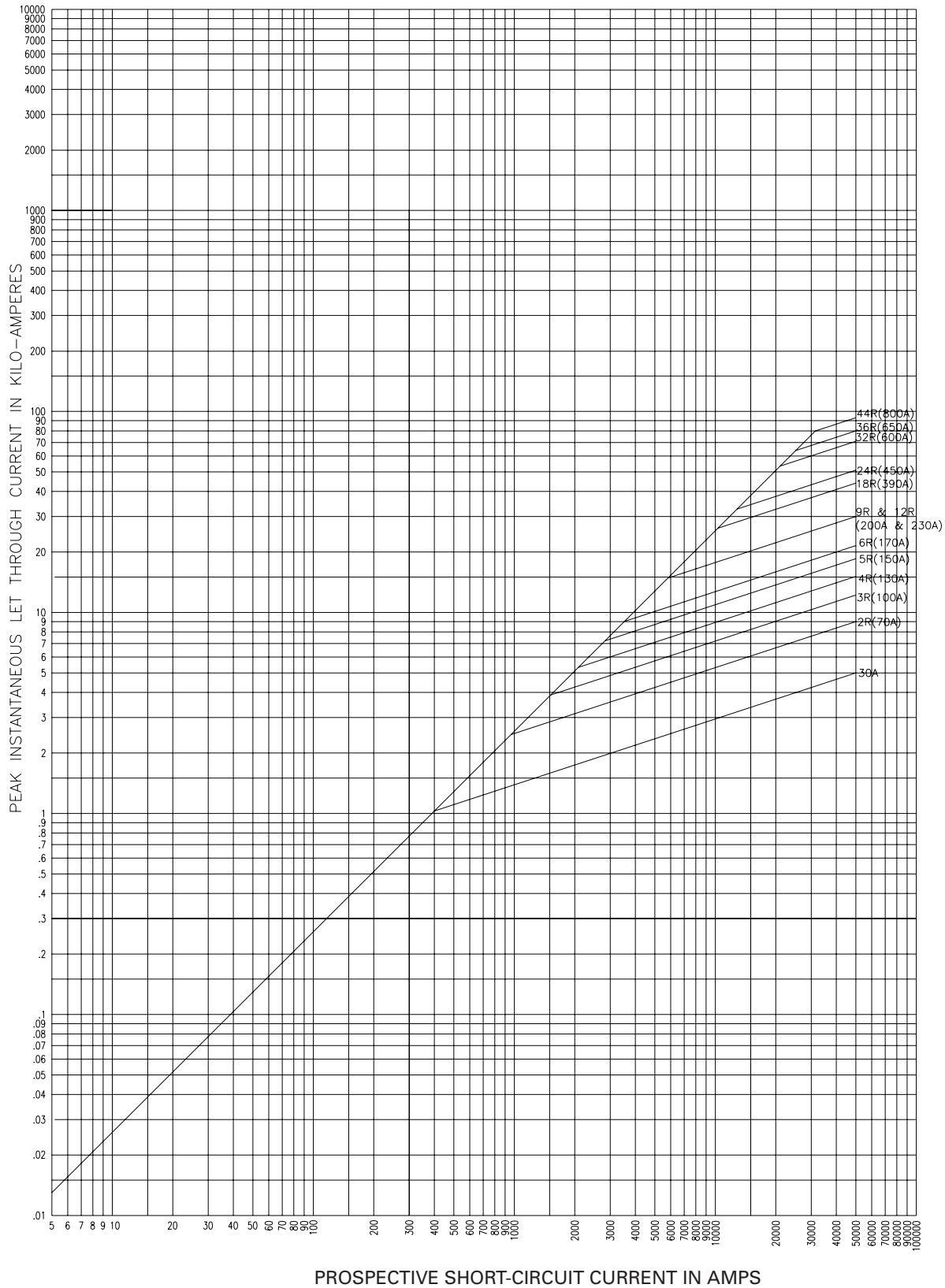

5ACLS-30, 5CLS-30, 5HCLS-<sub>R</sub>, 5BCLS-30, 5BCLS-<sub>R</sub>

CURVE 66700203  
 January 2001  
 Reference # 639315  
 667002, 667008

4.8kV Time-current curves — minimum melting for JCL-<sub>R</sub> and JCL-A-<sub>R</sub> (2R-24R @25°C)

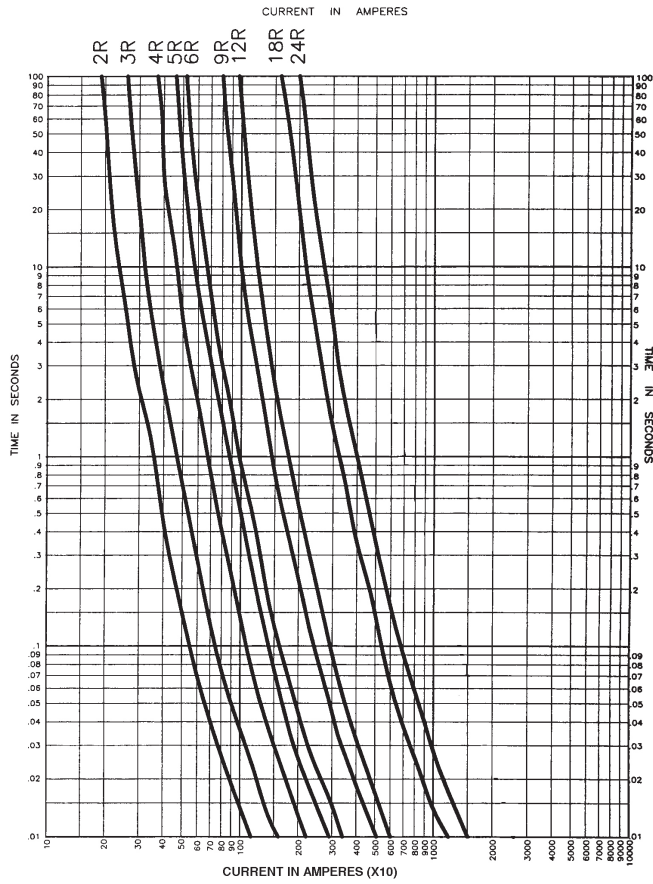

4.8kV Time-current curves — total clearing for JCL-<sub>R</sub> and JCL-A-<sub>R</sub> (2R-24R @25°C)

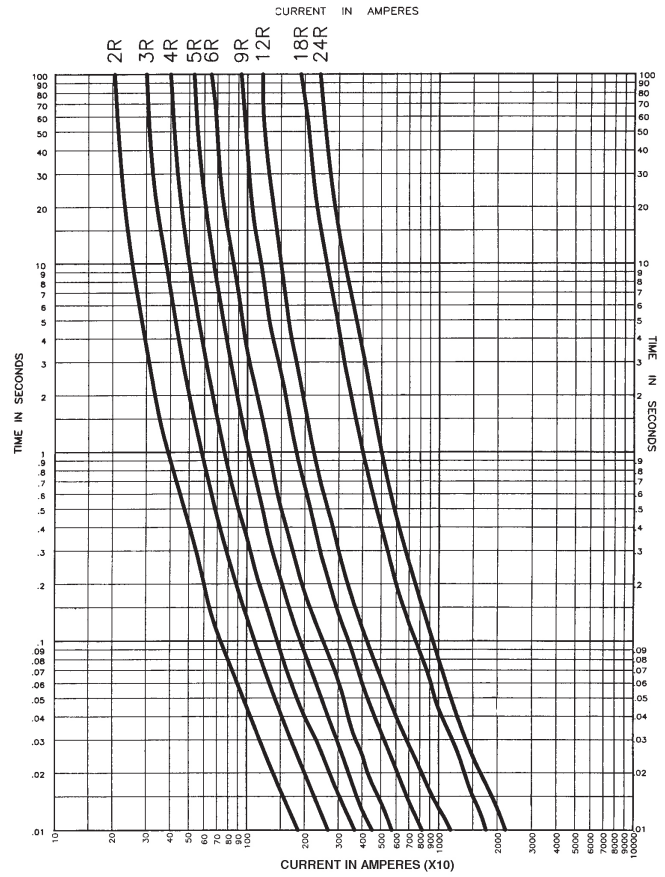

4.8kV Peak let-through curves for JCL-<sub>R</sub> and JCL-A-<sub>R</sub> (2R-24R @25°C)

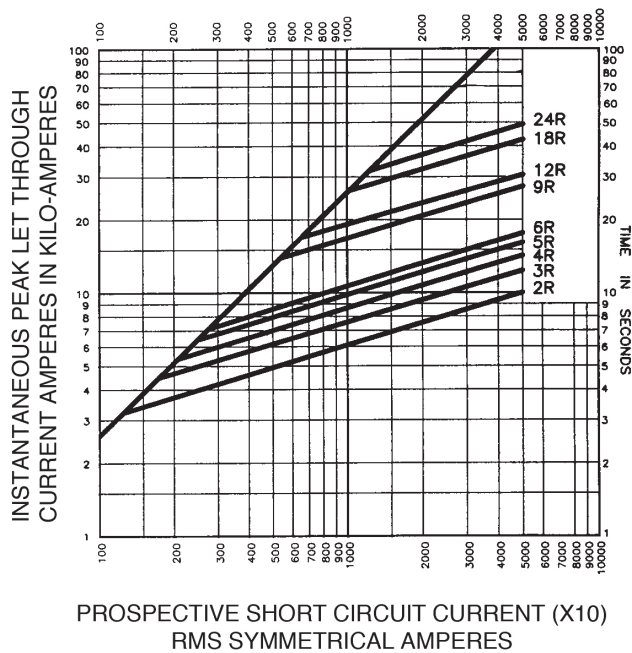

4.8kV Time-current curves — minimum melting for 5LCLS\_R (2R-24R @ 25°C)

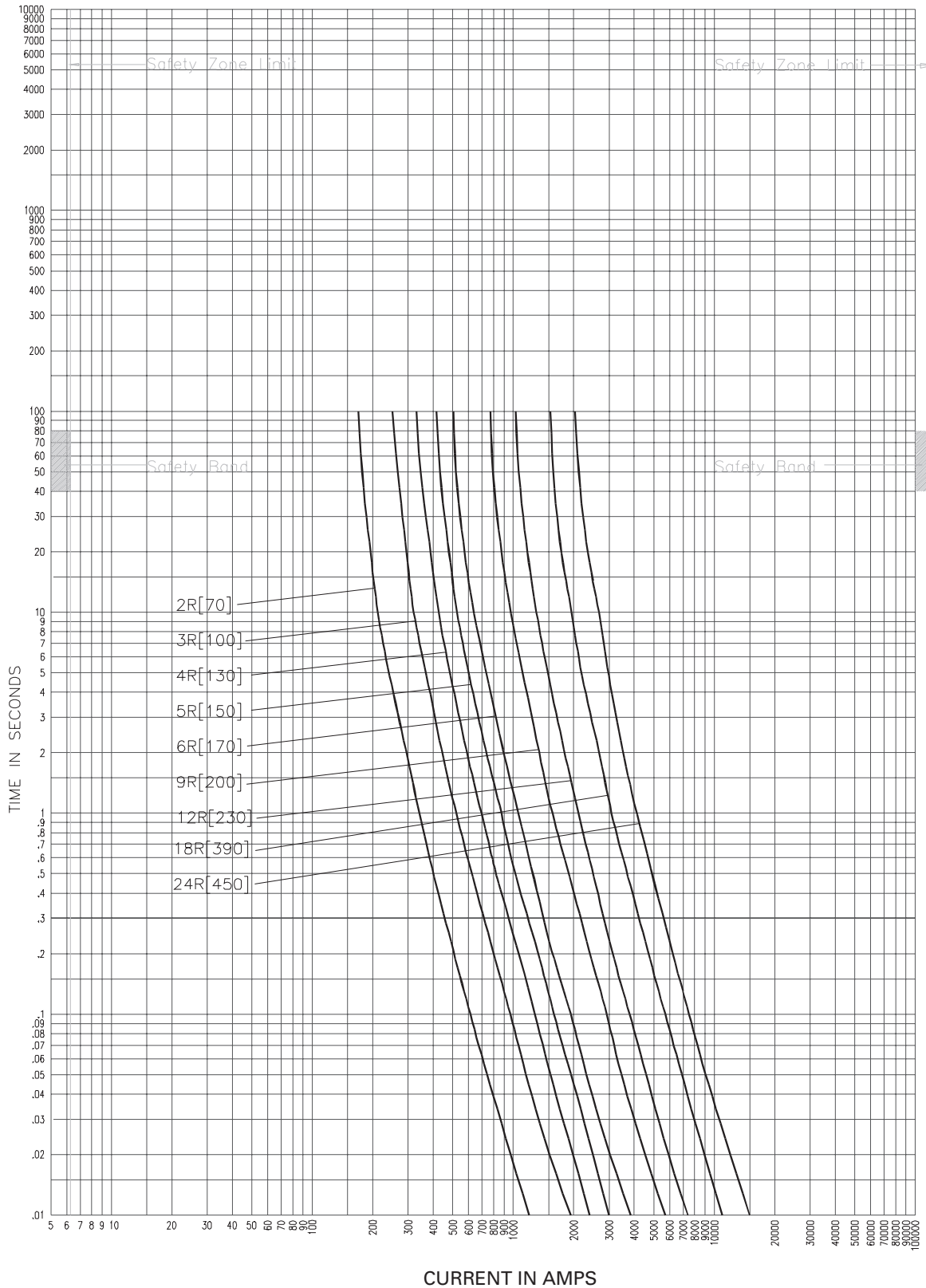

CURVE 51285302  
 January 2001  
 Reference # 512853,  
 563863.

5LCLS\_R

4.8kV Time-current curves — total clearing for 5LCLS-<sub>R</sub> (2R-24R @ 25°C)

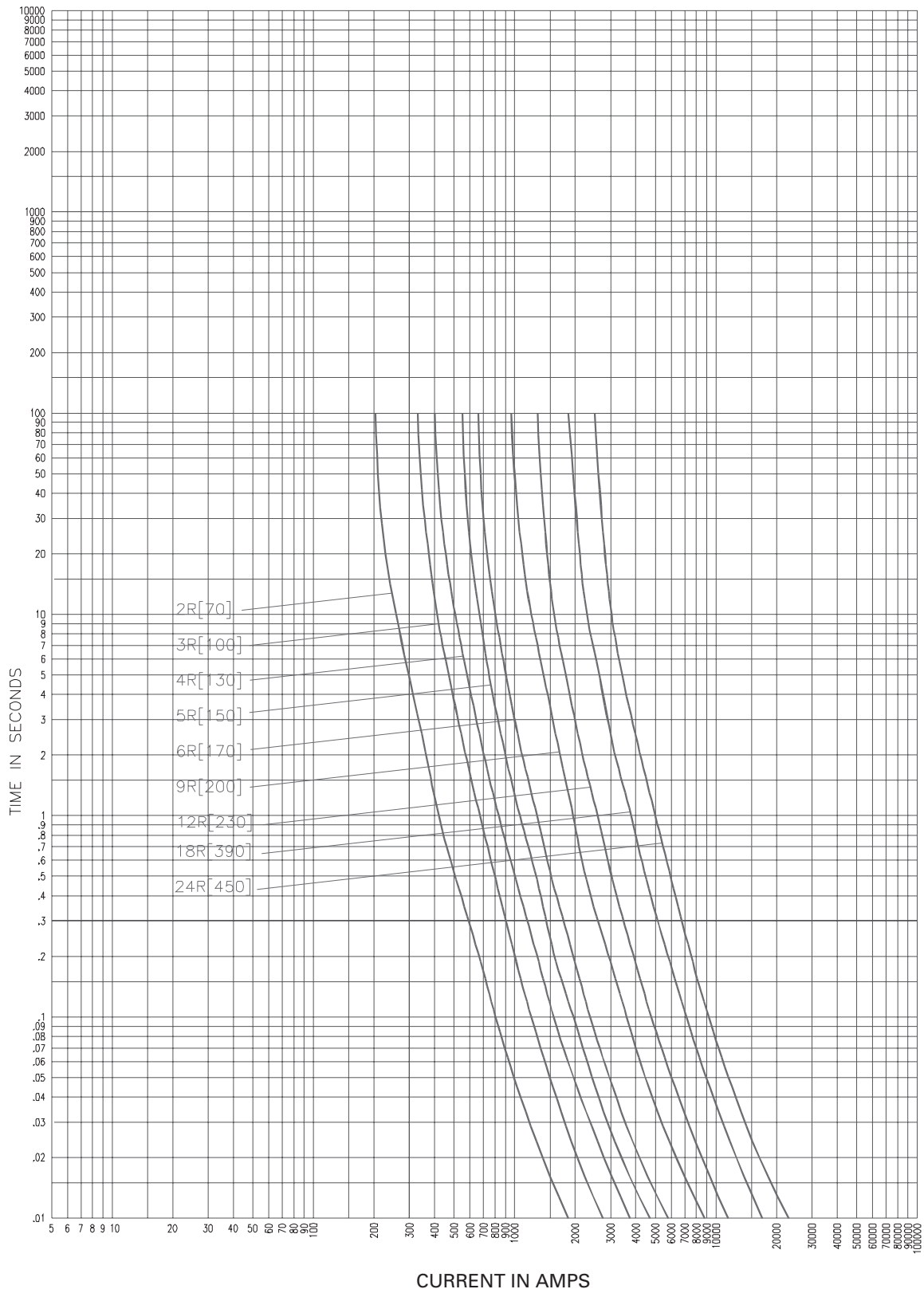

5LCLS-<sub>R</sub>

CURVE 51285402  
January 2001  
Reference # 512854,  
563864.

4.8kV Peak let-through curves for 5LCLS-<sub>R</sub> (2R-24R @ 25°C)

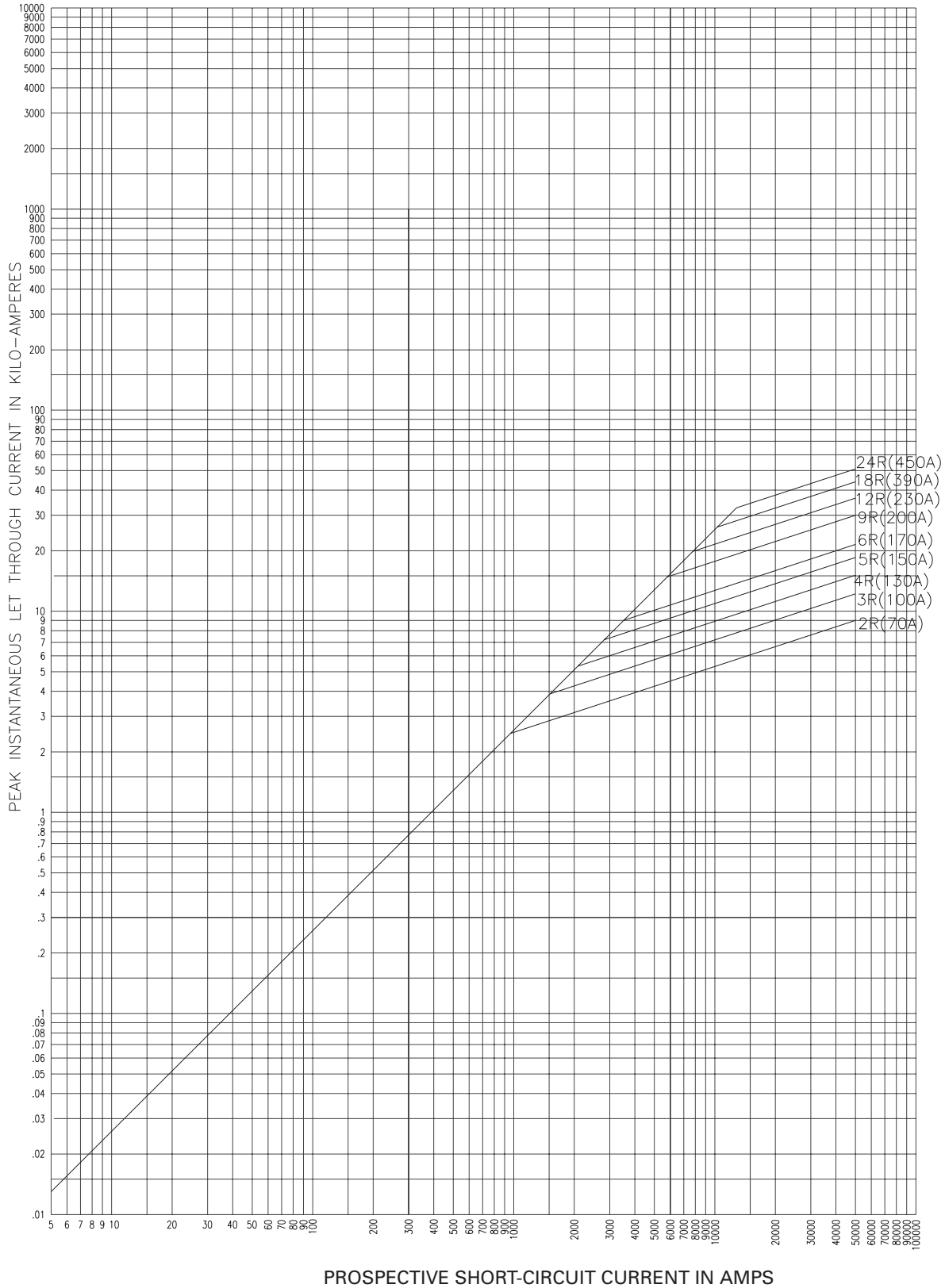

5LCLS-<sub>R</sub>

CURVE 66700204  
 January 2001  
 Reference # 639315

**7.2kV R-Rated fuses**

**Catalog symbols:**

| Code-(amps)R | Construction                |
|--------------|-----------------------------|
| 8CLS_R       | Standard (2R - 6R)          |
| 7CLS_R       | Standard (9R - 24R)         |
| 8ACLS_R      | AMPGARD Hookeye* (2R - 6R)  |
| 7ACLS_R      | AMPGARD Hookeye* (9R - 24R) |
| 7BCLS_R      | Bolt-on (2R - 44R)          |

\* For use in 400 amp AMPGARD motor starters.

**Ratings:**

- Volts
  - 7.2kV (nominal)
  - 8.3kV (max design 70-170A standard and AMPGARD Hookeye)
  - 7.2kV (max design 200-450A standard and AMPGARD Hookeye)
  - 7.2kV (max design 70-800 bolt-on)
- Amps 25-450A
- Interrupting ratings
  - 50kA Sym
  - 80kA Asym

**Recommended fuse holders for standard constructions:**

| Amp range                             | Description                            | BIL (kV)                     | Cat. No.   |
|---------------------------------------|--|------------------------------|------------|
| <b>Fuseclips</b>                      |  |                              |            |
| 70-230A                               | 3" Enclosed fuseclip*                  | —                            | A3354730   |
| 70-450A                               | 3" Open fuseclip                       | —                            | 1A0065     |
|                                       | 3" Spring loaded open fuseclip         | —                            | 9078A67G04 |
| <b>Fuse holders for 7CLS and 8CLS</b> |  |                              |            |
|                                       | Non-disconnect holder, porcelain       | 75                           | 8HLE-PNM-D |
| 70-230A                               | Non-disconnect holder, glass polyester | 75                           | 8HLE-GNM-D |
| Single barrel                         | Disconnect holder, porcelain           | 75                           | 8HLE-PDM-D |
|                                       | Disconnect holder, glass polyester     | 75                           | 8HLE-GDM-D |
|                                       | Non-disconnect holder, porcelain       | 75                           | 8HLE-PNM-E |
| 390-450A                              | Non-disconnect holder, glass polyester | 75                           | 8HLE-GNM-E |
|                                       | Double barrel                          | Disconnect holder, porcelain | 75         |
|                                       | Disconnect holder, glass polyester     | 75                           | 8HLE-GDM-E |

\* Single barrel only, not sold in pairs.

**Dimensions - in [mm]**

| Construction    | Amp range | Dimension  |            |         |          |
|-----------------|-----------|------------|------------|---------|----------|
|                 |           | A          | B          | C       | D        |
| Standard        | 70-230A   | 15.8 (401) | 3 (76)     | 3 (76)  | —        |
|                 | 390-450A  | 15.8 (401) | 3 (76)     | 3 (76)  | 3.3 (84) |
| AMPGARD Hookeye | 70-230A   | 15.8 (401) | 3 (76)     | 3 (76)  | —        |
|                 | 390-450A  | 15.8 (401) | 3 (76)     | 3 (76)  | 3.3 (84) |
| Bolt-on         | 70-230A   | 19.2 (488) | 17.9 (455) | 3 (76)  | —        |
|                 | 390-650A  | 19.2 (488) | 17.9 (455) | 3 (76)  | 3.3 (84) |
|                 | 800A      | 19.2 (488) | 17.9 (455) | 4 (102) | 3.3 (84) |

**Standard and AMPGARD Hookeye**

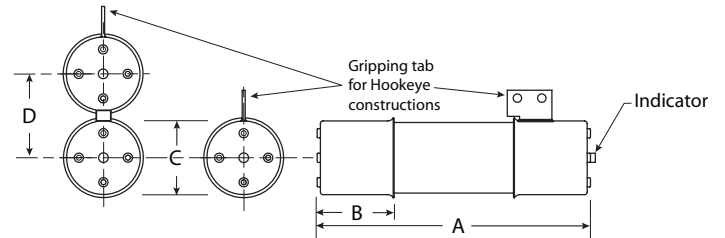

**Bolt-on**

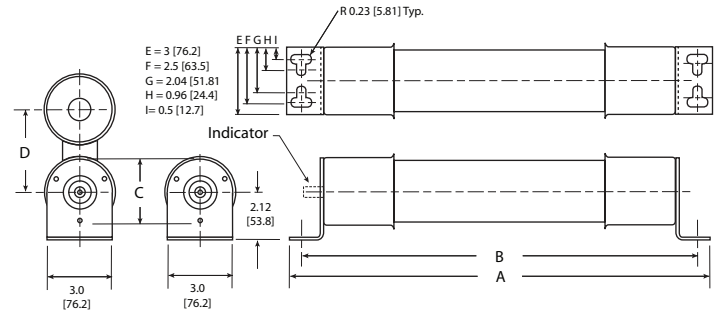

72kV R-Rated fuse catalog numbers

| Amp rating | "R" Designation | Mounting style (minimum interrupting rating in amps) |                  |                  | Number of barrels |
|------------|-----------------|--|------------------|------------------|-------------------|
|            |                 | Standard   | AMPGARD Hookeye  | Bolt-on          |                   |
| 70         | 2R              | 8CLS-2R (160)  | 8ACLS-2R (160)   | 7BCLS-2R (160)   | 1                 |
| 100        | 3R              | 8CLS-3R (250)  | 8ACLS-3R (250)   | 7BCLS-3R (250)   | 1                 |
| 130        | 4R              | 8CLS-4R (325)  | 8ACLS-4R (325)   | 7BCLS-4R (325)   | 1                 |
| 150        | 5R              | 8CLS-5R (390)  | 8ACLS-5R (390)   | 7BCLS-5R (390)   | 1                 |
| 170        | 6R              | 8CLS-6R (500)  | 8ACLS-6R (500)   | 7BCLS-6R (500)   | 1                 |
| 200        | 9R              | 7CLS-9R (750)  | 7ACLS-9R (750)   | 7BCLS-9R (750)   | 1                 |
| 230        | 12R             | 7CLS-12R (1000)                                      | 7ACLS-12R (1000) | 7BCLS-12R (1000) | 1                 |
| 390        | 18R             | 7CLS-18R (1450)                                      | 7ACLS-18R (1450) | 7BCLS-18R (1450) | 2                 |
| 450        | 24R             | 7CLS-24R (2500)                                      | 7ACLS-24R (2500) | 7BCLS-24R (2500) | 2                 |
| 650        | 36R             | —  | —                | 7BCLS-36R (3000) | 2                 |
| 800        | 44R             | —  | —                | 7BCLS-44R (3250) | 2                 |

8CLS, 8ACLS, 7CLS, 7ACLS Type mountings - in (mm)

| Catalog number                      | Hole centers  |           | Overall length<br>C | Hole inset<br>D | Hole centers<br>E | Contact height<br>F | Overall height<br>G | BIL rating (kV) |
|-------------------------------------|---------------|-----------|---------------------|-----------------|-------------------|---------------------|---------------------|-----------------|
|                                     | A             | B         |                     |                 |                   |                     |                     |                 |
| <b>Disconnect single barrel†</b>    |               |           |                     |                 |                   |                     |                     |                 |
| 8HLE-GDM-D                          | 16.25 (412.8) | 6 (152.4) | 23 (584.2)          | 0.62 (15.7)     | 1.75 (44.4)       | 7 (177.8)           | 11.72 (297.7)       | 75              |
| 8HLE-PDM-D                          | 16.25 (412.8) | 6 (152.4) | 23 (584.2)          | 0.62 (15.7)     | 1.75 (44.4)       | 7 (177.8)           | 11.72 (297.7)       | 75              |
| <b>Disconnect double barrel†</b>    |               |           |                     |                 |                   |                     |                     |                 |
| 8HLE-GDM-E                          | 16.25 (412.8) | 6 (152.4) | 23 (584.2)          | 0.62 (15.7)     | 1.75 (44.4)       | 7 (177.8)           | 17.78 (451.6)       | 75              |
| 8HLE-PDM-E                          | 16.25 (412.8) | 6 (152.4) | 23 (584.2)          | 0.62 (15.7)     | 1.75 (44.4)       | 7 (177.8)           | 17.78 (451.6)       | 75              |
| <b>Non-disconnect single barrel</b> |               |           |                     |                 |                   |                     |                     |                 |
| 8HLE-GNM-D                          | 16.25 (412.7) | 6 (152.4) | 23 (584.2)          | 0.62 (15.7)     | 1.75 (44.4)       | 7 (177.8)           | 11.29 (286.7)       | 75              |
| 8HLE-PNM-D                          | 16.25 (412.7) | 6 (152.4) | 23 (584.2)          | 0.62 (15.7)     | 1.75 (44.4)       | 7 (177.8)           | 11.29 (286.7)       | 75              |
| <b>Non-disconnect double barrel</b> |               |           |                     |                 |                   |                     |                     |                 |
| 8HLE-GNM-E                          | 16.25 (412.7) | 6 (152.4) | 23 (584.2)          | 0.62 (15.7)     | 1.75 (44.4)       | 7 (177.8)           | 14.98 (380.5)       | 75              |
| 8HLE-PNM-E                          | 16.25 (412.7) | 6 (152.4) | 23 (584.2)          | 0.62 (15.7)     | 1.75 (44.4)       | 7 (177.8)           | 14.98 (380.5)       | 75              |

72kV disconnect mounting†

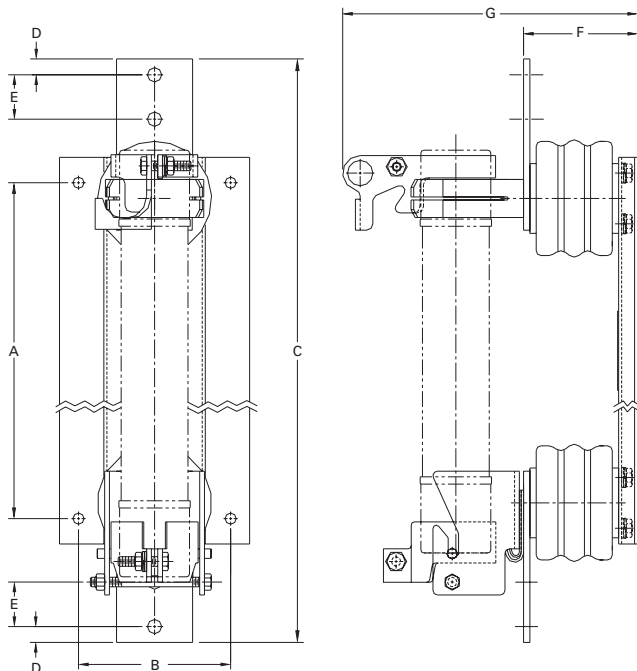

72kV non-disconnect mounting

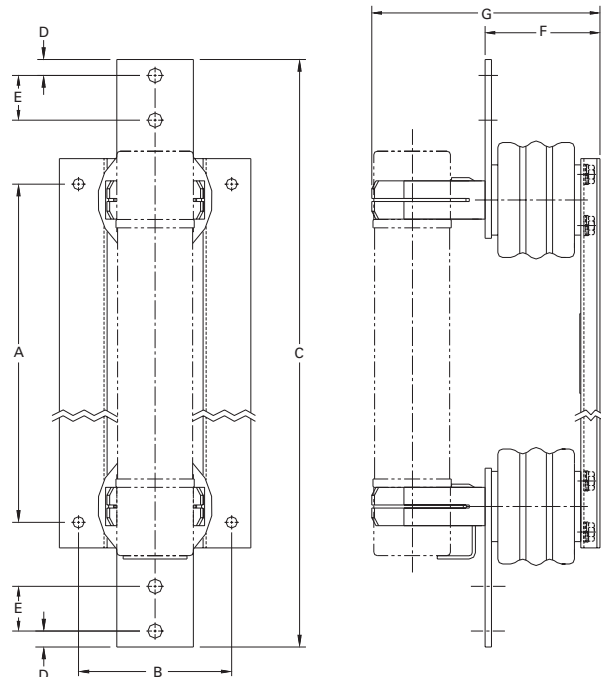

† Disconnect mountings provide a means for fuse extraction only. Do not use a disconnect mounting for load switching or fuse removal while energized.

7.2kV Time-current curves — minimum melting for 8CLS- R, 7CLS- R, 8ACLS- R, 7ACLS- R and 7BCLS- R (2R-44R @ 25C)

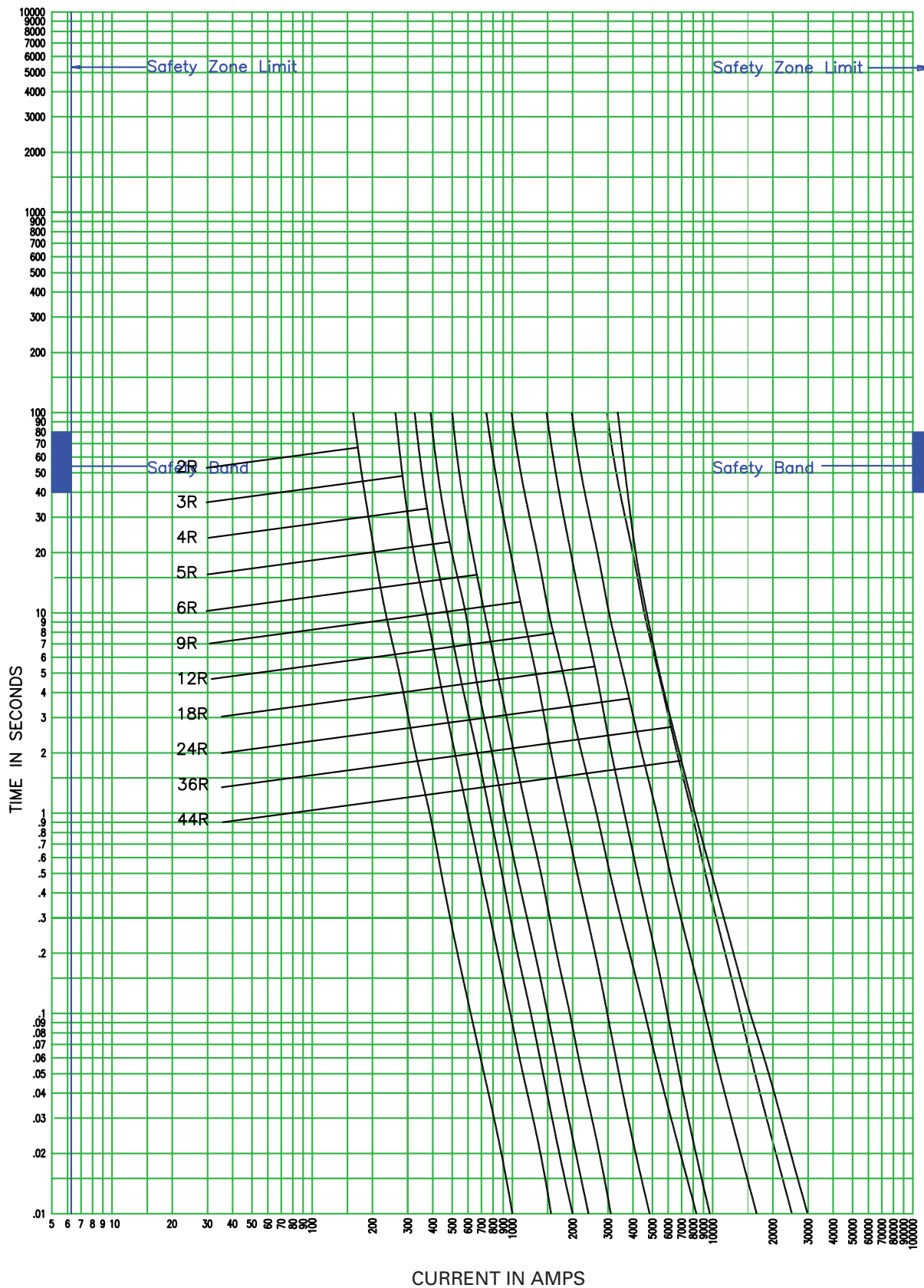

8CLS- R, 7CLS- R, 8ACLS- R, 7ACLS- R and 7BCLS- R

CURVE TC66700602  
December 2008

7.2kV Time-current curves — total clearing for 8CLS-<sub>R</sub>, 7CLS-<sub>R</sub>, 8ACLS-<sub>R</sub>, 7ACLS-<sub>R</sub> and 7BCLS-<sub>R</sub> (2R-44R @ 25C)

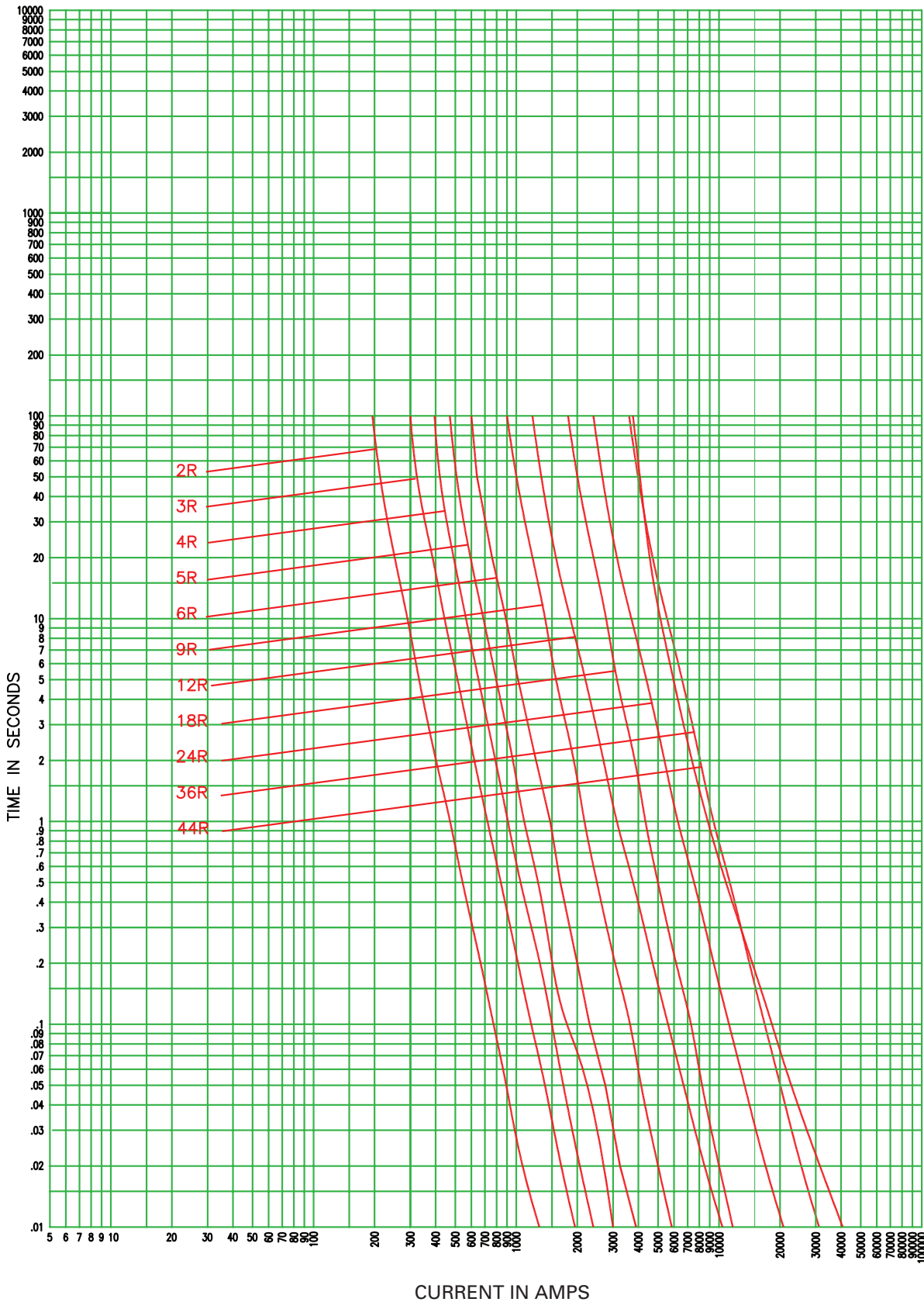

8CLS-<sub>R</sub>, 7CLS-<sub>R</sub>, 8ACLS-<sub>R</sub>, 7ACLS-<sub>R</sub> and 7BCLS-<sub>R</sub>

CURVE TC66700702  
December 2008

72kV Peak let-through curves for 8CLS-<sub>R</sub>, 7CLS-<sub>R</sub>, 8ACLS-<sub>R</sub>, 7ACLS-<sub>R</sub> and 7BCLS-<sub>R</sub> (2R-44R @ 25C)

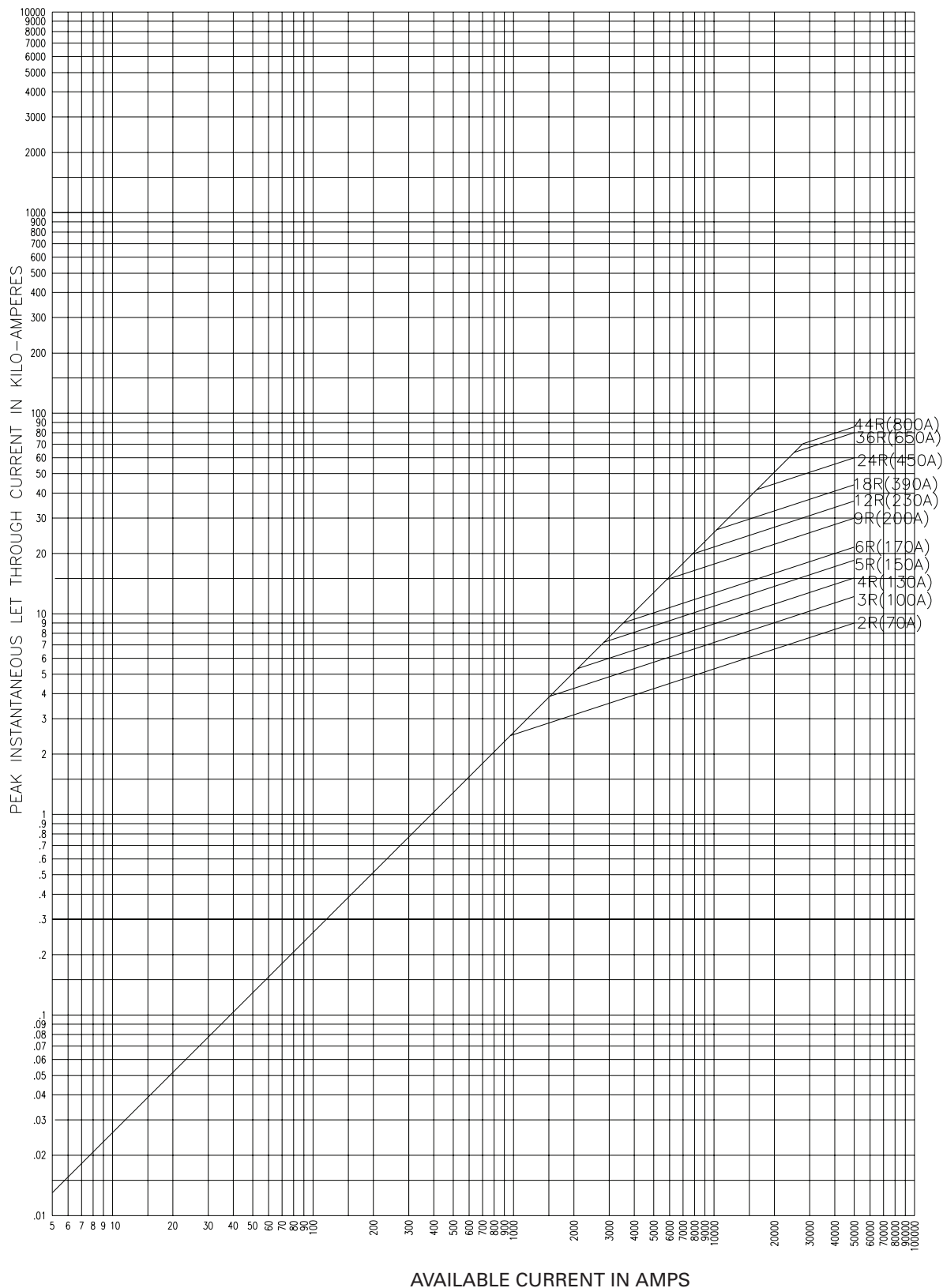

8CLS-<sub>R</sub>, 7CLS-<sub>R</sub>, 8ACLS-<sub>R</sub>, 7ACLS-<sub>R</sub> and 7BCLS-<sub>R</sub>

CURVE 66700205  
January 2001  
Reference # 639315  
667002, 667008

The only controlled copy of this Data Sheet is the electronic read-only version located on the Bussmann Network Drive. All other copies of this document are by definition uncontrolled. This bulletin is intended to clearly present comprehensive product data and provide technical information that will help the end user with design applications. Bussmann reserves the right, without notice, to change design or construction of any products and to discontinue or limit distribution of any products. Bussmann also reserves the right to change or update, without notice, any technical information contained in this bulletin. Once a product has been selected, it should be tested by the user in all possible applications.

**Eaton's Bussmann Business**

114 Old State Road  
Ellisville, MO 63021  
United States  
[www.bussmann.com](http://www.bussmann.com)

© 2015 Eaton  
All Rights Reserved  
Publication No. 6001 - BU-SB15148  
April 2015

Eaton is a registered trademark.

All other trademarks are property  
of their respective owners.