

REV	REVISIONS	DRN	APP	DATE
A	NEW RELEASE	JGL	NO	8/06/2020
B	REVISED NOTE 5 & 8 TO INCLUDE 598-8F10-302F & ITS QUANTITY	LD	NO	7-29-21

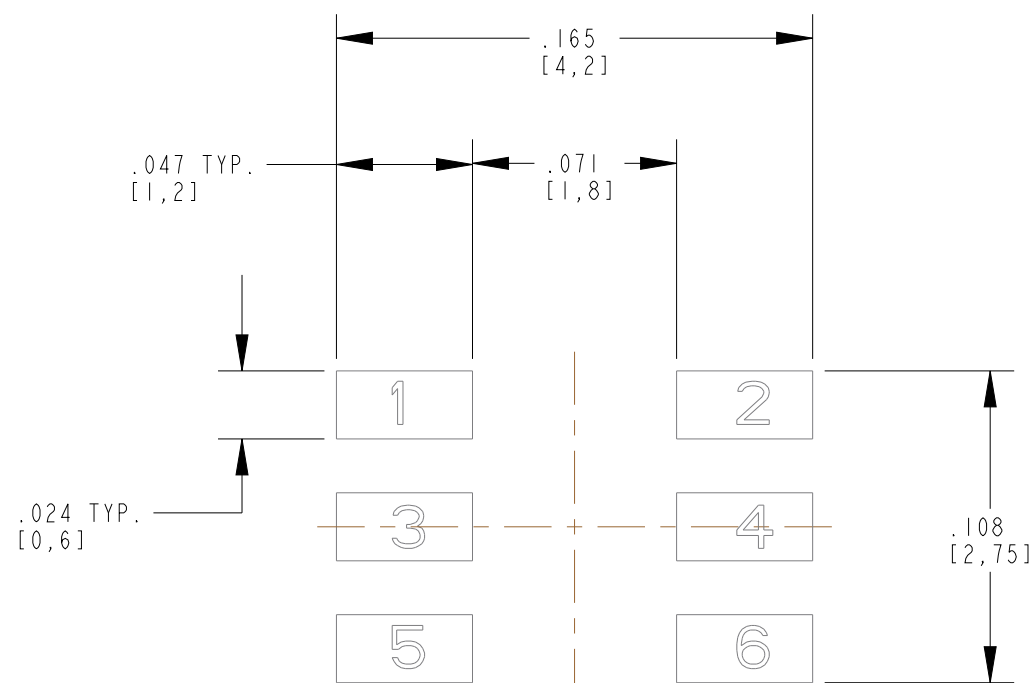

SOLDER PAD LAYOUT

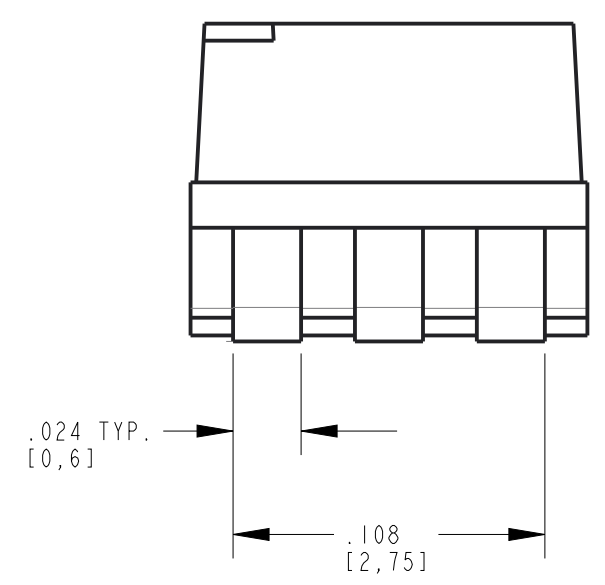
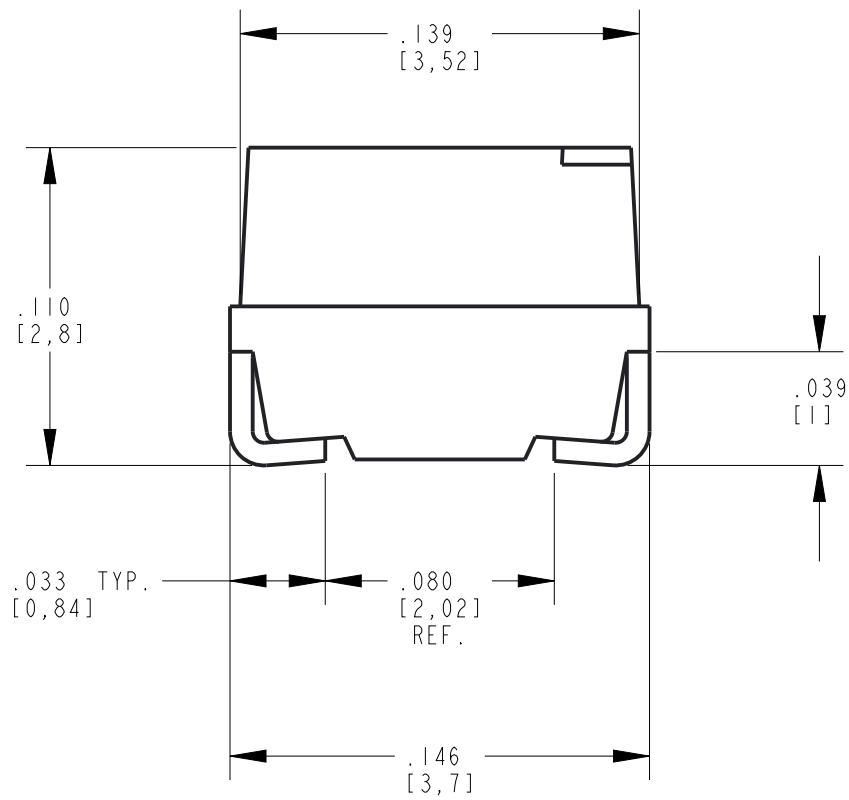
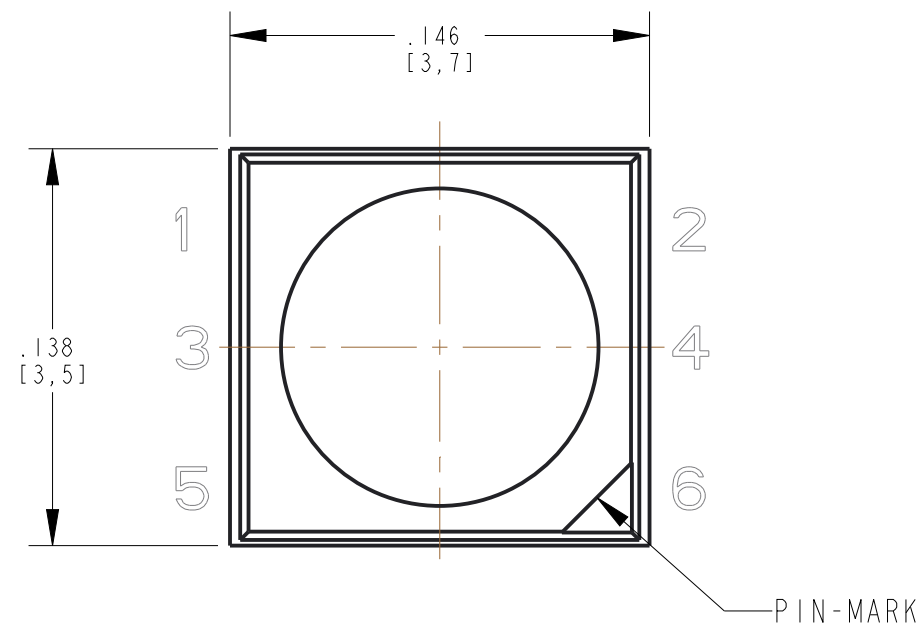
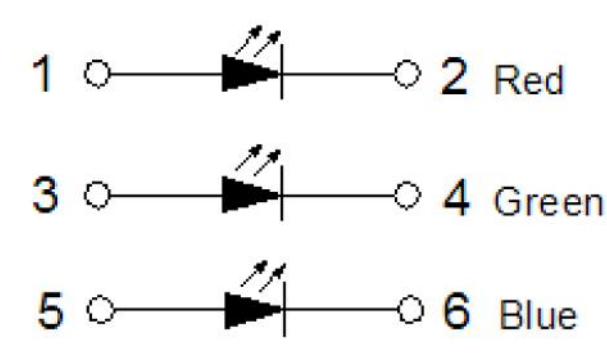

LED SCHEMATIC

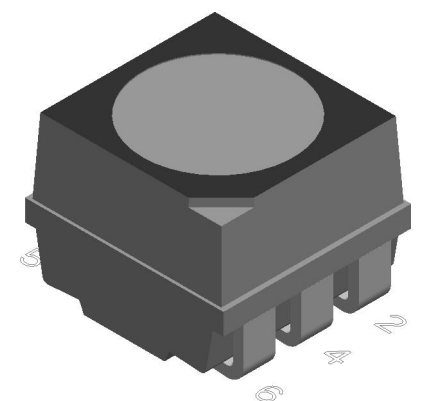

SCALE 10.000

- NOTES:
- PIN NUMBERS ARE FOR REFERENCE ONLY, DESIGNATION NON EXISTENT ON PART.
 - LABELING FOR REEL AND OUTSIDE OF ALUMINUM BAG, DIALIGHT P/N QUANTITY PER REEL, DATE CODE, INTENSITY BIN CODE, LOT NUMBER AND COUNTRY OF ORIGIN.
 - STORAGE CONDITIONS FOR TAPED PRODUCTS: RE-TAPING MAY BE NECESSARY FOR PRODUCTS STORED MORE THAN 12 MONTHS.
 - DRY PACK PACKAGING CONSIST OF A DESICCANT, HUMIDITY INDICATOR CARD IN A VACUUM SEALED MOISTER BARRIERBAG, MOISTER SENSITIVITY LABEL LEVEL 5A ON OUTSIDE BAG.
 - QUANTITY: 3000 PIECES PER REEL/BAG. 20 PIECES PER STRIP
 - HBM CLASS 1B
 - OBSERVE PRECAUTIONS FOR HANDLING ELECTROSTATIC SENSITIVE DEVICES.
 - PART No: 598-8F10-313F (REEL)
598-8F10-302F (STRIP)

ELECTRICAL & OPTICAL CHARACTERISTICS (Ts=25°C)						
ITEM	SYMBOL	CONDITION	R	G	B	UNITS
REVERSE CURRENT	I_R	$V_R=5V$	6	6	6	μA
FORWARD VOLTAGE	$V_{F(min)}$	$I_F=20mA$				V
	$V_{F(avg)}$		2.1	3.0	3.0	V
	$V_{F(max)}$		2.4	3.6	3.6	V
DOMINANT WAVELENGTH	λ_D	$I_F=20mA$	618~628	518~528	464~474	nm
SPECTRUM RADIATION BANDWIDTH	$\Delta \lambda$	$I_F=20mA$	24	38	30	nm
LUMINOUS INTENSITY	$I_V(min)$	$I_F=20mA$	550	1600	300	mc d
	$I_V(avg)$		760	1900	450	mc d
VIEWING ANGLE	201/2	$I_F=20mA$	120			deg

MAXIMUM RATINGS (Ts=25°C)					
ITEM	SYMBOL	ABSOLUTE MAXIMUM RATING			UNITS
		R	G	B	
FORWARD CURRENT	I_F	25	25	25	mA
PULSE FORWARD CURRENT	I_{FP}	100	100	100	mA
REVERSE VOLTAGE	V_R	5	5	5	V
OPERATING TEMPERATURE	T_{OPR}	-30~+85			°C
STORAGE TEMPERATURE	T_{STG}	-40~+100			°C
POWER DISSIPATION	P_D	60	90	90	mW
ELECTROSTATIC DISCHARGE (HBM)	ESD	1000V			



ATTENTION:
OBSERVE PRECAUTIONS FOR
HANDLING ELECTROSTATIC
SENSITIVE DEVICES

THIS DRAWING AND THE CONTENTS HEREIN ARE CONFIDENTIAL AND THE SOLE PROPERTY OF DIALIGHT CORP. REPRODUCTION OF THIS DRAWING OR CONSTRUCTION OF ANY PARTS WITHIN THIS DRAWING ARE FORBIDDEN WITHOUT THE WRITTEN CONSENT OF DIALIGHT CORP.		
DIALIGHT CORP INTERNAL REFERENCE ONLY - 3D MODEL : 4500521857223-A.2		
SCALE: 15.000	DRAWING NUMBER	REV
ALL DIM'S IN: INCHES (MM)	C-18480	B
TOLERANCES: UNLESS OTHERWISE SPECIFIED	TITLE	
FRACTIONS: ±1/64	SM 3735 RGB W/6 LEADS	
DECIMALS (.XX): ±.01	MATERIAL	
DECIMALS (.XXX): ±.005		
DECIMALS (.XXXX): ±.0005		
ANGLES: ±1°		
FINISH		
FSCM 83330	1501 ROUTE 34 SOUTH FARMINGDALE, NJ 07727 (732) 919-3119 www.dialight.com	
SHEET 1 OF 2	FAMILY TABLE:	

SMT REFLOW SOLDERING INSTRUCTIONS

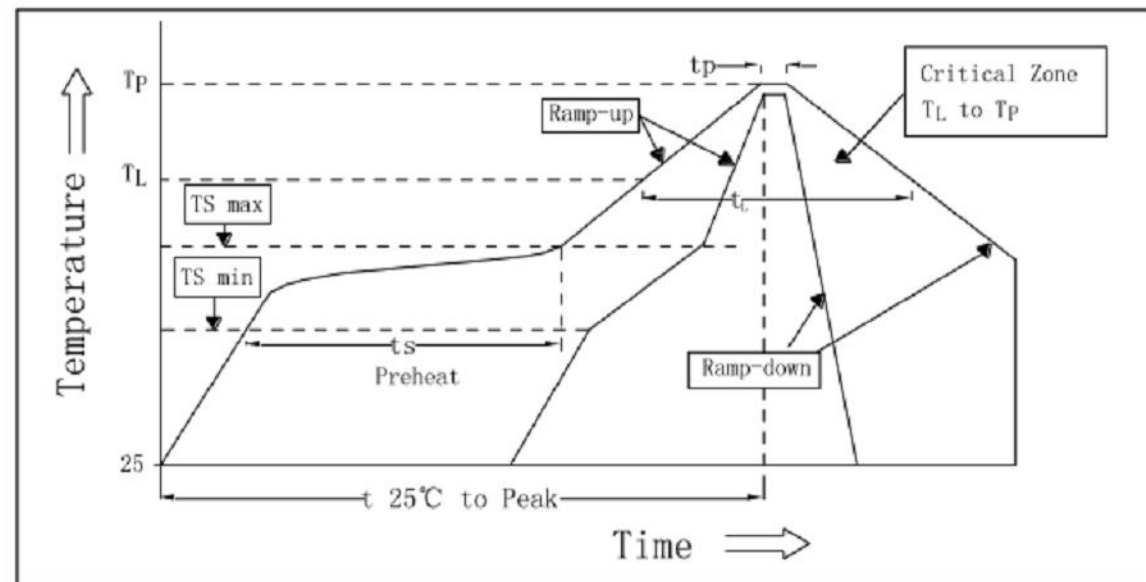

AVERAGE TEMPERATURE RISE SPEED ($T_{S\ max}$ to T_p)	MAX 4°C/s
PREHEATING: MINIMUM TEMPERATURE ($T_{S\ min}$)	150°C
PREHEATING: MAX. TEMPERATURE ($T_{S\ max}$)	200°C
PREHEATING: TIME ($T_{S\ min}$ to $T_{S\ max}$)	60s-120s
TIME LIMITED TO MAINTAIN HIGH TEMPERATURE: THE TEMPERATURE	217°C
TIME LIMITED TO MAINTAIN HIGH TEMPERATURE: THE TIME	MAX 60s
PEAK/CLASSIFICATION OF TEMPERATURE: (T_p)	250°C
SOLDERING TIME:	MAX 10s
RAMP-DOWN RATE:	6°C/s max

SOLDERING NOTES:

1. REFLOW SOLDERING SHOULD NOT BE DONE MORE THAN ONE TIMES.
2. IT IS RECOMMENDED THE USE OF MIDDLE TEMPERATURE SOLDER PASTE.
3. STRESS ON THE LEDS SHOULD BE AVOIDED DURING HEATING IN SOLDERING PROCESS.
4. AFTER SOLDERING, DO NOT DEAL WITH THE PRODUCT BEFORE TEMPERATURE IS DOWN TO ROOM TEMPERATURE.

13 INCH DIA. REEL SPECIFICATIONS

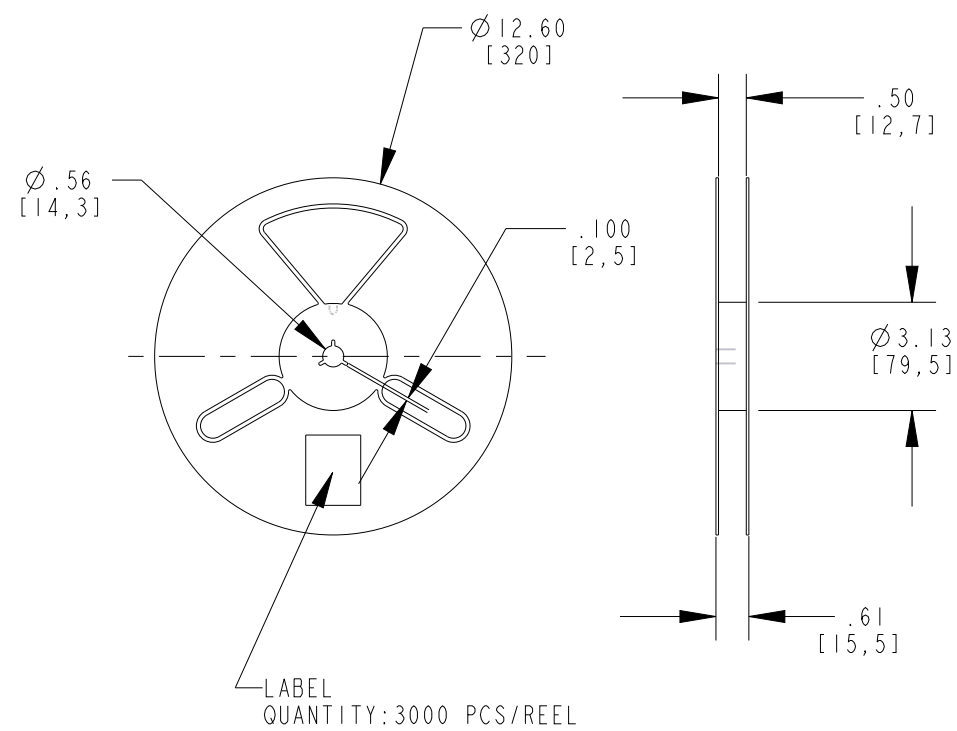

CARRIER TAPE - FEEDING DIRECTION

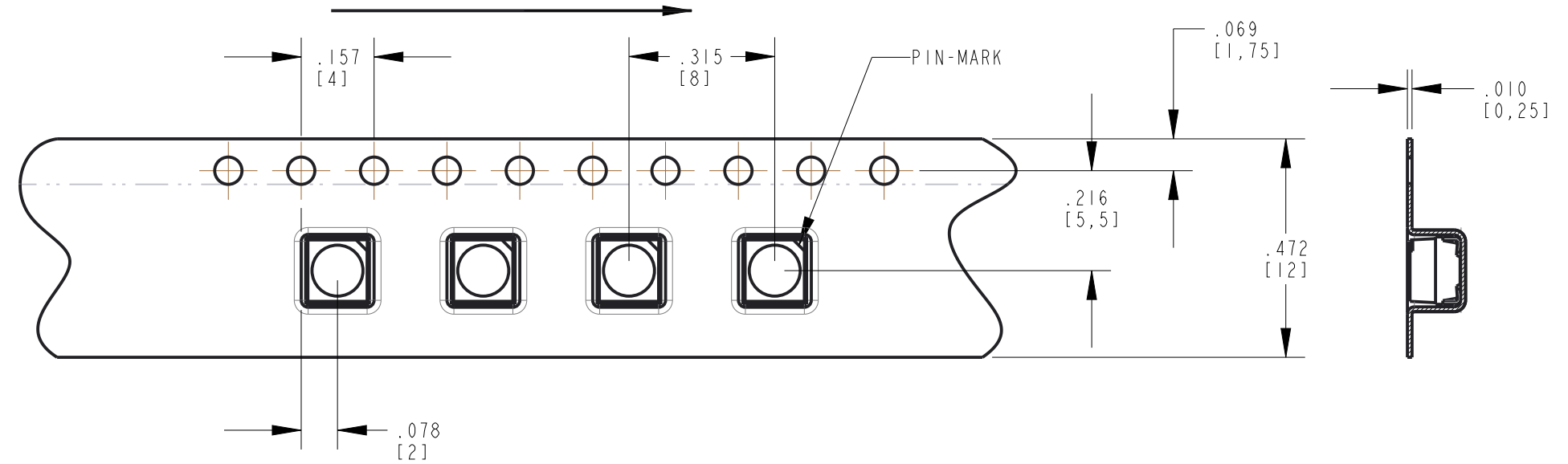

ATTENTION:
OBSERVE PRECAUTIONS FOR
HANDLING ELECTROSTATIC
SENSITIVE DEVICES

THIS DRAWING AND THE CONTENTS HEREIN ARE CONFIDENTIAL AND THE SOLE PROPERTY OF DIALIGHT CORP. REPRODUCTION OF THIS DRAWING OR CONSTRUCTION OF ANY PARTS WITHIN THIS DRAWING ARE FORBIDDEN WITHOUT THE WRITTEN CONSENT OF DIALIGHT CORP.		
DIALIGHT CORP. INTERNAL REFERENCE ONLY - 3D MODEL : 4500521857223-SOLDER-PAD-A-2		
SCALE: 15.000	DRAWING NUMBER	REV
ALL DIM'S IN: INCHES (MM)	C-18480	B
TOLERANCES: UNLESS OTHERWISE SPECIFIED	TITLE	
FRACTIONS: $\pm 1/64$	SM 3735 RGB W/6 LEADS	
DECIMALS (.XX): $\pm .01$	MATERIAL	
DECIMALS (.XXX): $\pm .005$		
DECIMALS (.XXXX): $\pm .0005$		
ANGLES: $\pm 1^\circ$		
FINISH		
FSCM 83330	1501 ROUTE 34 SOUTH FARMINGDALE, NJ 07727 (732) 919-3119 www.dialight.com	
SHEET 2 OF 2	FAMILY TABLE:	