

Operating Instructions and Parts Manual Model No: 54-101-150-2 & 54-101-300-1

Please read through this owners manual carefully before using your new tool. Use your tool properly and only for its intended use.

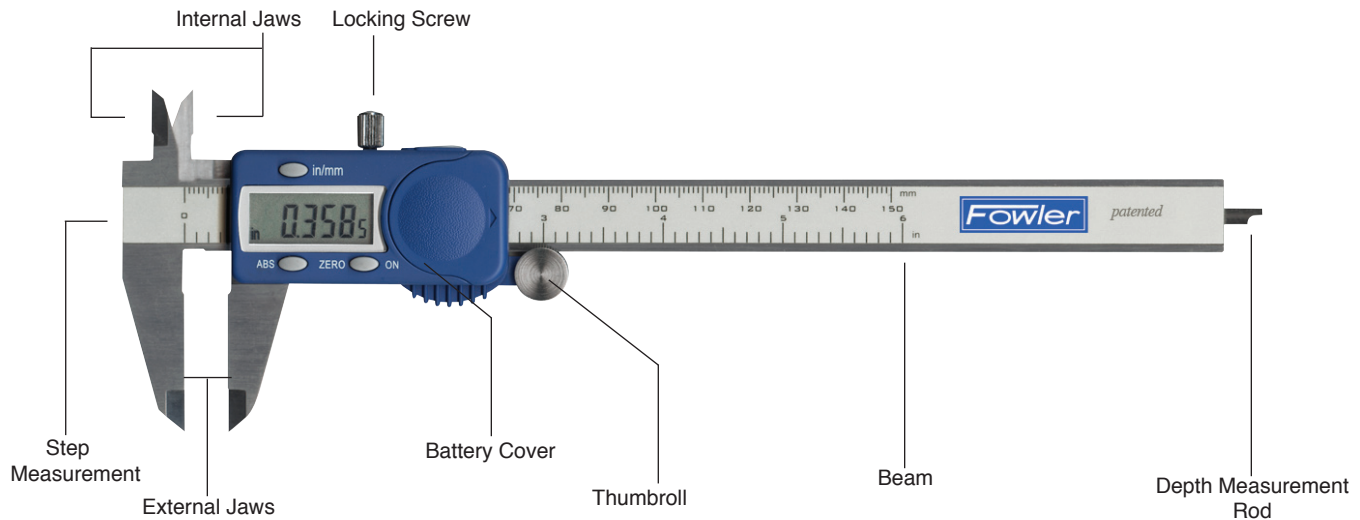

Electronic Caliper



Functions

On/Zero: Press <on> function button. Press button an additional time to zero. Caliper features auto-off function.

Zero Setting: Press <zero> function button.

Change Measuring Standard: Press <inch/mm> function button.

Absolute/Incremental: Press <abs> button, to return to zero function press button again.

RS232 data output: By connection cable (not included).The 54-100-004-1 does not have RS232 capabilities.

Battery Replacement

- Slide off the battery cover, then remove the battery by gently tapping the instrument in your hand. (Never try to force or pry the battery out). Insert the new battery with the positive pole "+" facing upwards and replace the cover.

- Please dispose of used batteries at a proper collection center.

Cleaning

Clean the caliper with a soft cloth and a few drops of clock oil. DO NOT use any type of solvent. DO NOT immerse the caliper in liquid.

Troubleshooting Chart

Symptom

- Digits do not change or count correctly
- No Display

Corrective Action

- Remove the battery for 30 seconds then reinstall.
- Check battery contacts or replace battery.

RESET: In order to RESET the instrument, remove the battery, wait 30 seconds, replace the battery and turn the instrument on.

Precautions: Although a top quality product, certain precautions are required for any electronic instrument:

- Avoid exposure to all liquids and excessive humidity.
- Avoid exposure to electromagnetic fields.
- Do not expose the instrument to direct sunlight.
- Do not attempt to disassemble the caliper for extended periods of time.

Technical Data

Measuring Range:	0-6"/150mm or 0-12"/300mm
Resolution:	.0005"/.01mm
Accuracy:	6"/150mm: ±.001"/.02mm; 12"/300mm: ±.0016"/.04mm
• Repeatability:	.0005"/.01mm
• Measuring system:	Capacitive
• Display:	LCD (7.0 mm high)
• Maximum Measuring Speed:	120° per second
• Battery:	3V, type CR2032 Lithium (Part #: 5U085)
• Battery life:	Approx. 1 year
• Operational Temperature Range:	0°C to +40°C
• Maximum Relative Humidity:	80%

DISTRIBUTED BY:

All-Spec Industries
Wilmington, NC
www.all-spec.com

1-800-537-0351 (phone)
1-800-379-9903 (fax)
sales@all-spec.com

