

## 超低抖动晶体振荡器 (XO)

### 特性

- 在 100 MHz 至 312.5 MHz 之间的选定频率下可用
- 第 3 代 DSPLL®, 具有卓越的抖动性能和和大功率电源噪声抑制
- 频率稳定性是基于 SAW 的振荡器的 3 倍
- 在 LVPECL 和 LVDS 输出下可用
- 3.3 和 2.5 V 电源选项
- 符合行业标准的 5 x 7 mm 封装和引脚分配
- 无铅 / 符合 RoHS

### 应用

- 10/40/100G 数据中心
- 10G 以太网交换机 / 路由器
- 光纤信道 / SAS / 存储
- 企业级服务器
- 网络
- 电信

### 说明

Si535/536 XO 采用 Skyworks Solutions 先进的 DSPLL® 电路, 可在高速差分频率下 提供超低抖动时钟。不同于传统的 XO 对于各个输出频率都需要使用不同的 晶体, Si535/536 使用一个固定晶体即可提供宽范围的输出频率。借助这个基于 IC 的方法, 晶体谐振器的频率稳定性和可靠性达到一流水平。另外, DSPLL 时钟合成提供了出色的电源噪声抑制, 简化了在嘈杂环境中生成低抖动时钟的任务 (常见于通信系统中)。基于 Si535/536 IC 的 XO 在发货时由工厂编程, 从而消除了与定制振荡器相关的长交付周期。

### 功能方框图

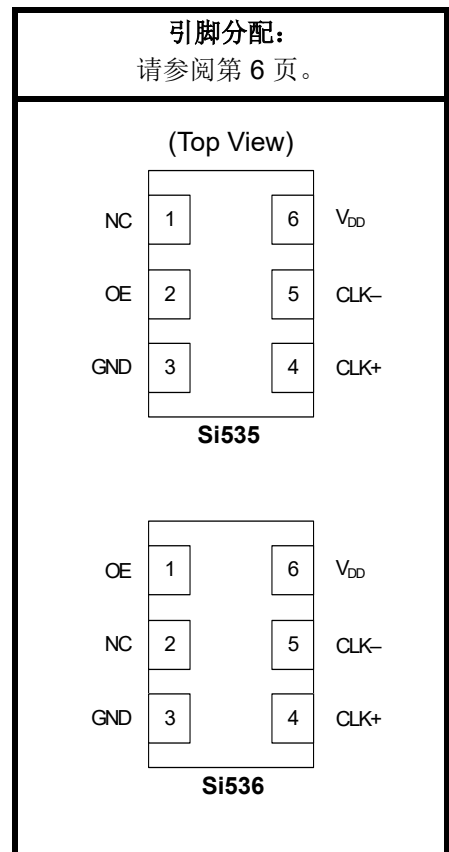
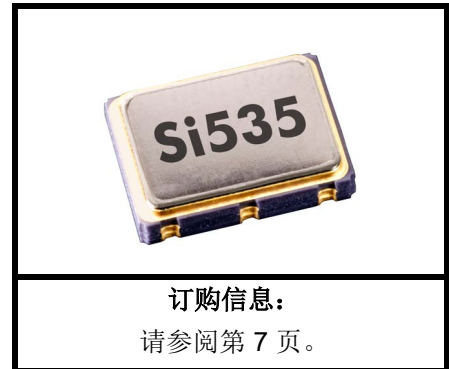
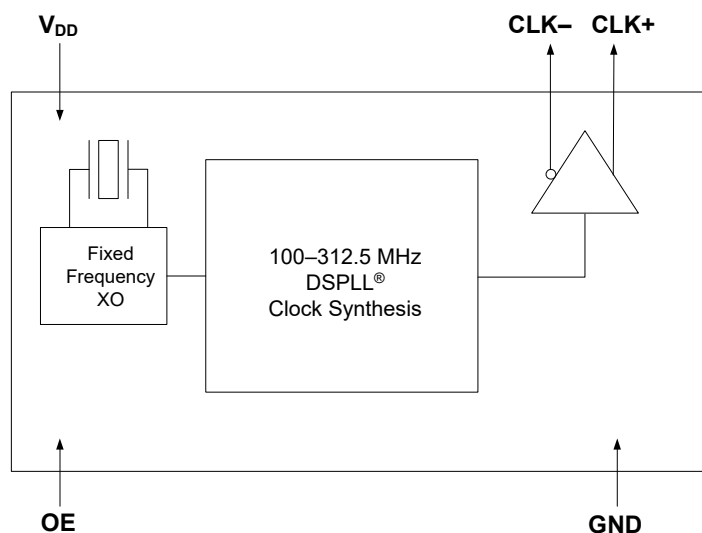

## 1. Electrical Specifications

**Table 1. Recommended Operating Conditions**

Parameter	Symbol	Test Condition	Min	Typ	Max	Unit
Supply Voltage <sup>1</sup>	V <sub>DD</sub>	3.3 V option	2.97	3.3	3.63	V
		2.5 V option	2.25	2.5	2.75	V
Supply Current	I <sub>DD</sub>	Output enabled LVPECL	—	111	121	mA
		LVDS	—	90	98	
		Tristate mode	—	60	75	mA
Output Enable (OE) <sup>2</sup>		V <sub>IH</sub>	0.75 x V <sub>DD</sub>	—	—	V
		V <sub>IL</sub>	—	—	0.5	V
Operating Temperature Range	T <sub>A</sub>		–40	—	85	°C

**Notes:**

- Selectable parameter specified by part number. See Section 3. "Ordering Information" on page 7 for further details.
- OE pin includes a 17 kΩ pullup resistor to V<sub>DD</sub>.

**Table 2. CLK± Output Frequency Characteristics**

Parameter	Symbol	Test Condition	Min	Typ	Max	Unit
Nominal Frequency <sup>1</sup>	f <sub>O</sub>	LVPECL/LVDS	100	—	312.5	MHz
Initial Accuracy	f <sub>i</sub>	Measured at +25 °C at time of shipping	—	±1.5	—	ppm
Temperature Stability <sup>1,2</sup>			–7 –20	— —	+7 +20	ppm
Aging	f <sub>a</sub>	Frequency drift over first year	—	—	±3	ppm
		Frequency drift over 20 year life	—	—	±10	ppm
Total Stability <sup>2</sup>		Temp stability = ±20 ppm	—	—	±31.5	ppm
		Temp stability = ±7 ppm	—	—	20	
Powerup Time <sup>3</sup>	t <sub>OSC</sub>	T <sub>A</sub> = –40°C — +85°C	—	—	10	ms

**Notes:**

- See Section 3. "Ordering Information" on page 7 for the list of available frequencies.
- Selectable parameter specified by part number.
- Time from powerup or tristate mode to f<sub>O</sub>.

Table 3. CLK± Output Levels and Symmetry

Parameter	Symbol	Test Condition	Min	Typ	Max	Unit
LVPECL Output Option <sup>1</sup>	V <sub>O</sub>	Mid-level	V <sub>DD</sub> - 1.42	—	V <sub>DD</sub> - 1.25	V
	V <sub>OD</sub>	Swing (diff)	1.1	—	1.9	V <sub>PP</sub>
	V <sub>SE</sub>	Swing (Single-ended)	0.55	—	0.95	V <sub>PP</sub>
LVDS Output Option <sup>2</sup>	V <sub>O</sub>	Mid-level	1.125	1.20	1.275	V
	V <sub>OD</sub>	Swing (diff)	0.5	0.7	0.9	V <sub>PP</sub>
Rise/Fall time (20/80%)	t <sub>R</sub> , t <sub>F</sub>		—	—	350	ps
Symmetry (duty cycle)	SYM	Differential	45	—	55	%
<b>Notes:</b>						
1. 50 Ω to V <sub>DD</sub> - 2.0 V.						
2. R <sub>term</sub> = 100 Ω (differential).						

# Si535/536

**Table 4. CLK± Output Phase Jitter**

Parameter	Symbol	Test Condition	Min	Typ	Max	Unit
LVPECL/LVDS Phase Jitter* (RMS)	$\phi_J$	10 kHz to 1 MHz (data center)	—	0.19	0.35	ps
		12 kHz to 20 MHz brickwall	—	0.25	0.40	ps

**\*Note:** Applies to output frequencies: 156.25 MHz.

**Table 5. CLK± Output Period Jitter**

Parameter	Symbol	Test Condition	Min	Typ	Max	Unit
LVPECL/LVDS Period Jitter*	$J_{PER}$	RMS	—	2	—	ps
		Peak-to-Peak	—	14	—	ps

**\*Note:** N = 1000 cycles.



**Figure 1. Si535/536 Typical Phase Noise at 156.25 MHz**

**Table 6. Environmental Compliance**

The Si535/536 meets the following qualification test requirements.

Parameter	Conditions/Test Method
Mechanical Shock	MIL-STD-883, Method 2002
Mechanical Vibration	MIL-STD-883, Method 2007
Solderability	MIL-STD-883, Method 2003
Gross & Fine Leak	MIL-STD-883, Method 1014
Resistance to Solder Heat	MIL-STD-883, Method 2036
Moisture Sensitivity Level	J-STD-020, MSL1
Contact Pads	Gold over Nickel

**Table 7. Thermal Characteristics**

(Typical values  $T_A = 25\text{ }^\circ\text{C}$ ,  $V_{DD} = 3.3\text{ V}$ )

Parameter	Symbol	Test Condition	Min	Typ	Max	Unit
Thermal Resistance Junction to Ambient	$\theta_{JA}$	Still Air	—	84.6	—	$^\circ\text{C/W}$
Thermal Resistance Junction to Case	$\theta_{JC}$	Still Air	—	38.8	—	$^\circ\text{C/W}$
Ambient Temperature	$T_A$		-40	—	85	$^\circ\text{C}$
Junction Temperature	$T_J$		—	—	125	$^\circ\text{C}$

**Table 8. Absolute Maximum Ratings<sup>1</sup>**

Parameter	Symbol	Rating	Unit
Maximum Operating Temperature	$T_{AMAX}$	85	$^\circ\text{C}$
Supply Voltage, 2.5/3.3 V Option	$V_{DD}$	-0.5 to +3.8	V
Input Voltage (any input pin)	$V_I$	-0.5 to $V_{DD} + 0.3$	V
Storage Temperature	$T_S$	-55 to +125	$^\circ\text{C}$
ESD Sensitivity (HBM, per JESD22-A114)	ESD	2500	V
Soldering Temperature (Pb-free profile) <sup>2</sup>	$T_{PEAK}$	260	$^\circ\text{C}$
Soldering Temperature Time @ $T_{PEAK}$ (Pb-free profile) <sup>2</sup>	$t_P$	20–40	seconds

**Notes:**

- Stresses beyond those listed in Absolute Maximum Ratings may cause permanent damage to the device. Functional operation or specification compliance is not implied at these conditions. Exposure to maximum rating conditions for extended periods may affect device reliability.
- The device is compliant with JEDEC J-STD-020C. Refer to Si5xx Packaging FAQ available for download at [https://www.skyworksinc.com/Product\\_Certificate.aspx](https://www.skyworksinc.com/Product_Certificate.aspx) for further information, including soldering profiles.

# Si535/536

## 2. Pin Descriptions

(Top View)

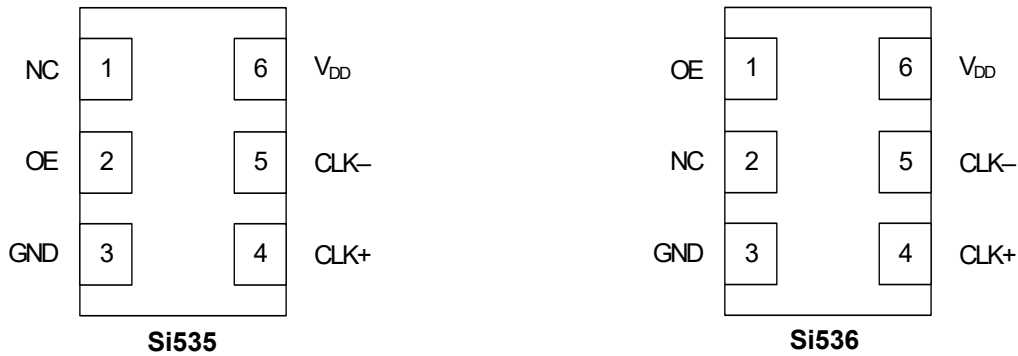

**Table 9. Pinout for Si535 Series**

Pin	Symbol	Function
1	NC	No connection
2	OE	Output enable 0 = clock output disabled (outputs tristated) 1 = clock output enabled
3	GND	Electrical and Case Ground
4	CLK+	Oscillator Output
5	CLK-	Complementary Output
6	V <sub>DD</sub>	Power Supply Voltage

**\*Note:** OE includes a 17 kΩ pullup resistor to V<sub>DD</sub>.

**Table 10. Pinout for Si536 Series**

Pin	Symbol	Function
1	OE	Output enable 0 = clock output disabled (outputs tristated) 1 = clock output enabled
2	No connection	No connection
3	GND	Electrical and Case Ground
4	CLK+	Oscillator Output
5	CLK-	Complementary output
6	V <sub>DD</sub>	Power Supply Voltage

**\*Note:** OE includes a 17 kΩ pullup resistor to V<sub>DD</sub>.

### 3. Ordering Information

The Si535/536 XO supports a variety of options including frequency, temperature stability, output format, and  $V_{DD}$ . The Si535 and Si536 XO series are supplied in an industry-standard, RoHS compliant, 6-pad, 5 x 7 mm package. The Si536 Series supports an alternate OE pinout (pin #1) for the LVPECL and LVDS output formats. See Tables 9 and 10 for the pinout differences between the Si535 and Si536 series.

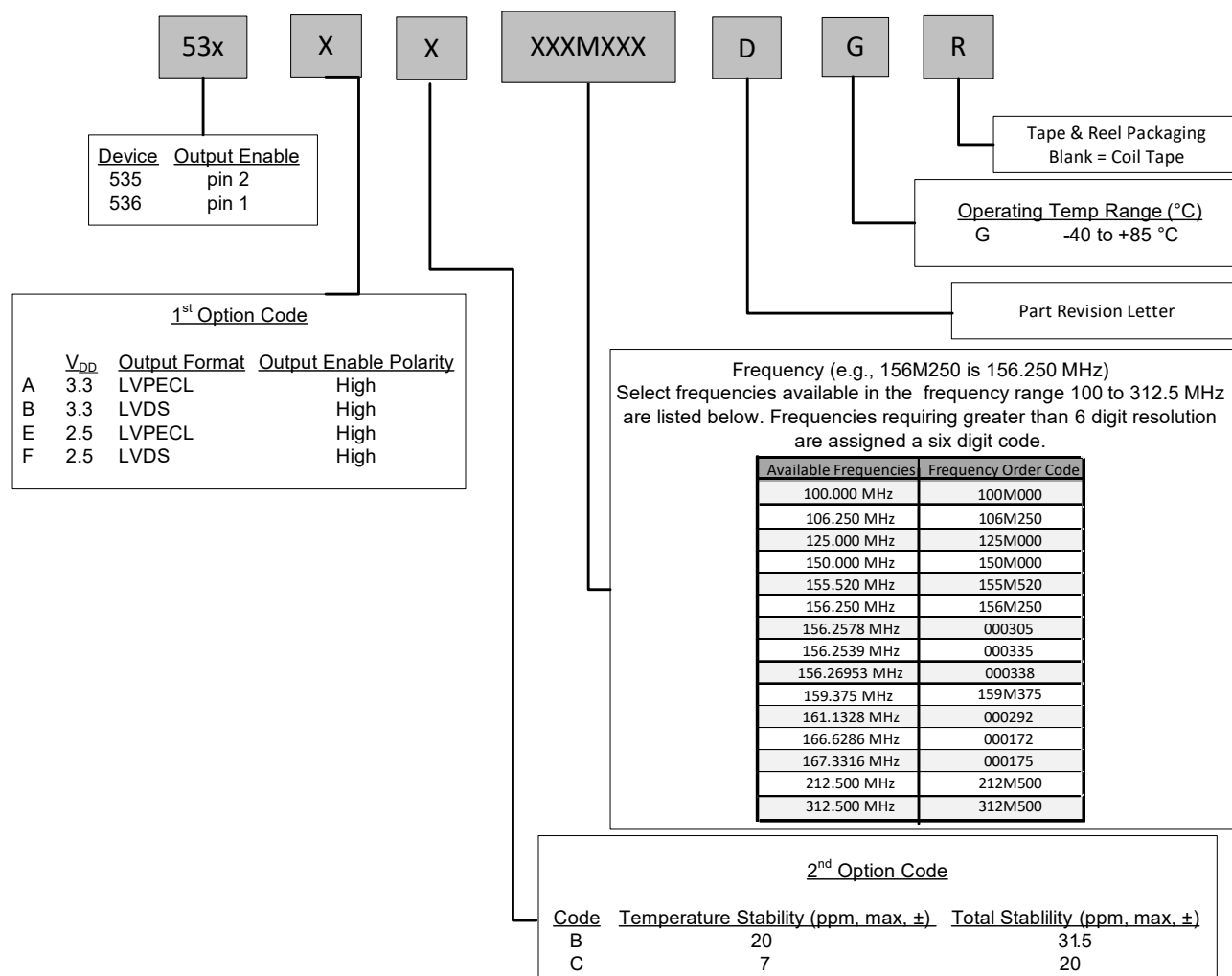

Example P/N: 535AB156M250DGR is a 5 x 7 XO in a 6 pad package. The frequency is 156.250 MHz, with a 3.3 V supply, LVPECL output, and Output Enable active high polarity. Temperature stability is specified as  $\pm 20$  ppm. The part is specified for  $-40$  to  $+85$  °C ambient temperature range operation and is shipped in tape and reel format.

**Figure 2. Part Number Convention**

## 4. Package Outline

Figure 3 illustrates the package details for the Si535/536. Table 11 lists the values for the dimensions shown in the illustration.

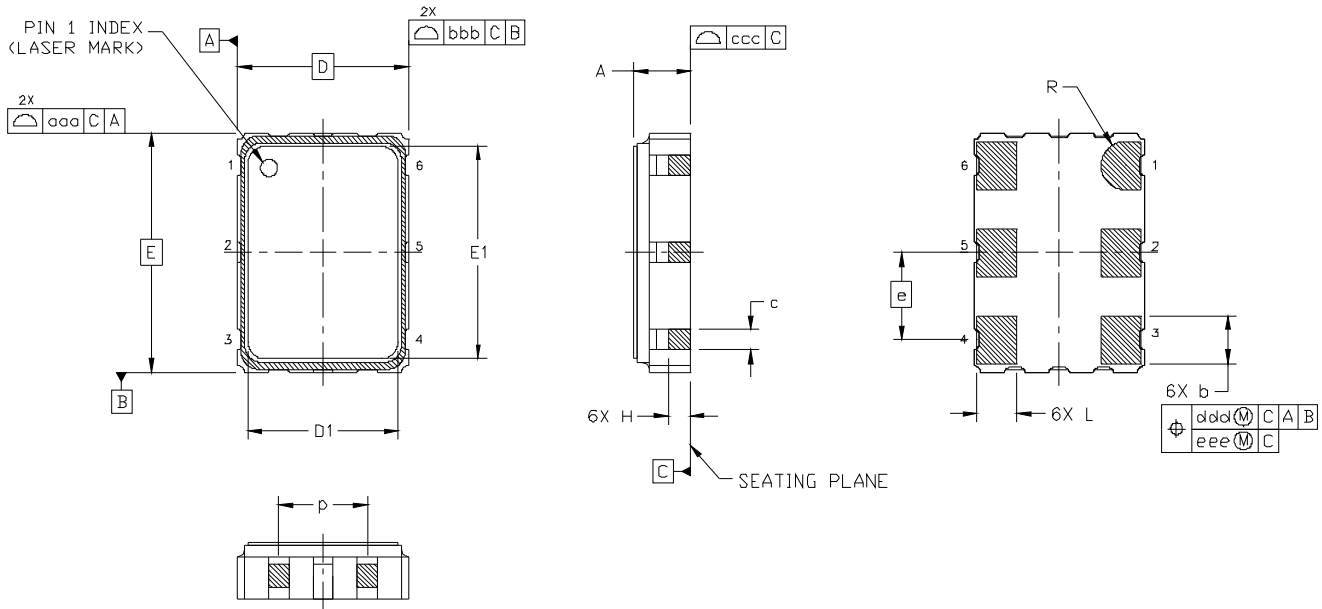

**Figure 3. Si535/536 Outline Diagram**

**Table 11. Package Diagram Dimensions (mm)**

Dimension	Min	Nom	Max
A	1.50	1.65	1.80
b	1.30	1.40	1.50
c	0.50	0.60	0.70
D	5.00 BSC		
D1	4.30	4.40	4.50
e	2.54 BSC		
E	7.00 BSC		
E1	6.10	6.20	6.30
H	0.55	0.65	0.75
L	1.17	1.27	1.37
p	1.80	—	2.60
R	0.70 REF		
aaa	0.15		
bbb	0.15		
ccc	0.10		
ddd	0.10		
eee	0.05		

## 5. 6-Pin PCB Land Pattern

Figure 4 illustrates the 6-pin PCB land pattern for the Si535/536. Table 12 lists the values for the dimensions shown in the illustration.

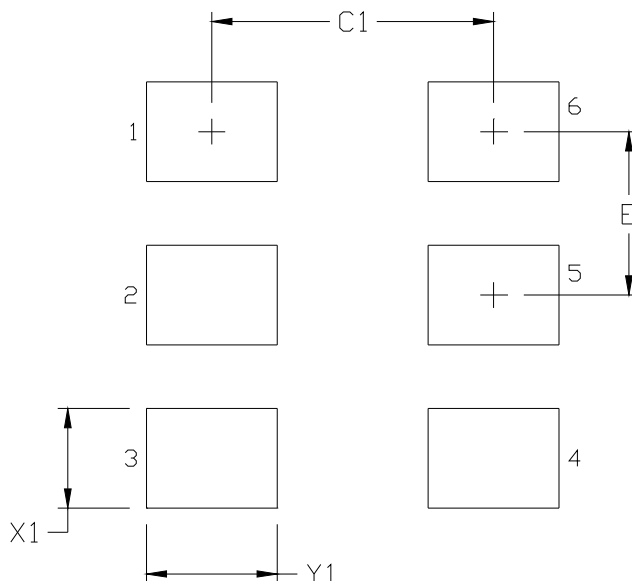

Figure 4. Si535/536 PCB Land Pattern

Table 12. PCB Land Pattern Dimensions (mm)

Dimension	Min
C1	4.20
E	2.54
X1	1.55
Y1	1.95

### Notes:

#### General

1. All dimensions shown are in millimeters (mm) unless otherwise noted.
2. Dimensioning and Tolerancing is per the ANSI Y14.5M-1994 specification.
3. This Land Pattern Design is based on the IPC-7351 guidelines.
4. All dimensions shown are at Maximum Material Condition (MMC). Least Material Condition (LMC) is calculated based on a Fabrication Allowance of 0.05 mm.

#### Solder Mask Design

1. All metal pads are to be non-solder mask defined (NSMD). Clearance between the solder mask and the metal pad is to be 60  $\mu\text{m}$  minimum, all the way around the pad.

#### Stencil Design

1. A stainless steel, laser-cut and electro-polished stencil with trapezoidal walls should be used to assure good solder paste release.
2. The stencil thickness should be 0.125 mm (5 mils).
3. The ratio of stencil aperture to land pad size should be 1:1.

#### Card Assembly

1. A No-Clean, Type-3 solder paste is recommended.
2. The recommended card reflow profile is per the JEDEC/IPC J-STD-020 specification for Small Body Components.

# Si535/536

## 6. Si535/Si536 Mark Specification

Figure 5 illustrates the mark specification for the Si535/Si536. Table 13 lists the line information.

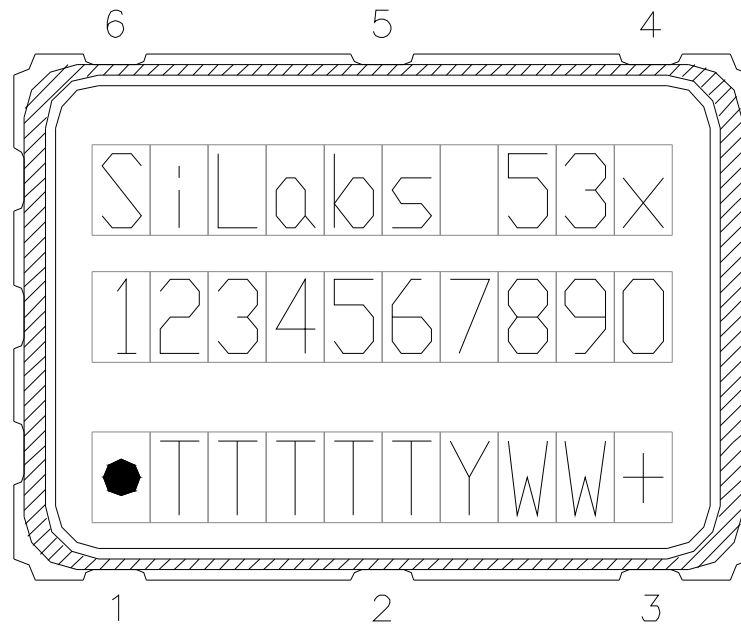

**Figure 5. Mark Specification**

**Table 13. Si53x Top Mark Description**

Line	Position	Description
1	1–10	“SiLabs”+ Part Family Number, 53x (First 3 characters in part number where x = 5 indicates a 535 device and x = 6 indicates a 536 device).
2	1–10	Si535, Si536: Option1 + Option2 + Freq(7) + Temp Si535/Si536 w/ 8-digit resolution: Option1 + Option2 + ConfigNum(6) + Temp
3	<b>Trace Code</b>	
	Position 1	Pin 1 orientation mark (dot)
	Position 2	Product Revision (D)
	Position 3–6	Tiny Trace Code (4 alphanumeric characters per assembly release instructions)
	Position 7	Year (least significant year digit), to be assigned by assembly site (ex: 2013 = 3)
	Position 8–9	Calendar Work Week number (1–53), to be assigned by assembly site
	Position 10	“+” to indicate Pb-Free and RoHS-compliant

## DOCUMENT CHANGE LIST

### Revision 0.2 to Revision 0.3

- Updated Table 7 on page 5.

### Revision 0.3 to Revision 0.5

- Updated Note 1 in Table 2 on page 2.
- Updated Symmetry Test Condition in Table 3 on page 3.
- Updated Table 4 on page 4.
- Updated Table 5 on page 4.
- Updated XXXMXXX text in Figure 2 on page 7.
- Updated 4. "Package Outline" on page 8.

### Revision 0.5 to Revision 0.6

- Updated Figure 2 on page 7.
- Updated Land Pattern information on page 10.

### Revision 0.6 to Revision 0.7

- Updated Powerup Time's test condition in Table 2 on page 2.
- Added new frequency option to Figure 2 on page 7.

### Revision 0.7 to Revision 1.0

- Updated Table 4 Phase Jitter's test condition and maximum values.

### Revision 1.0 to Revision 1.1

- Added 100 MHz ordering option.

### Revision 1.1 to Revision 1.2

May 13, 2016

- Updated Figure 2 for frequencies: 161.1328 MHz, 166.6286 MHz, 167.3316 MHz.

### Revision 1.2 to Revision 1.3

June, 2018

- Changed "Trays" to "Coil Tape" in section 3. "Ordering Information".



# SKYWORKS®

## ClockBuilder Pro

Customize Skyworks clock generators, jitter attenuators and network synchronizers with a single tool. With CBPro you can control evaluation boards, access documentation, request a custom part number, export for in-system programming and more!

[www.skyworksinc.com/CBPro](http://www.skyworksinc.com/CBPro)



**Portfolio**

[www.skyworksinc.com/ia/timing](http://www.skyworksinc.com/ia/timing)



**SW/HW**

[www.skyworksinc.com/CBPro](http://www.skyworksinc.com/CBPro)

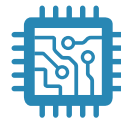

**Quality**

[www.skyworksinc.com/quality](http://www.skyworksinc.com/quality)



**Support & Resources**

[www.skyworksinc.com/support](http://www.skyworksinc.com/support)

### Copyright © 2021 Skyworks Solutions, Inc. All Rights Reserved.

Information in this document is provided in connection with Skyworks Solutions, Inc. ("Skyworks") products or services. These materials, including the information contained herein, are provided by Skyworks as a service to its customers and may be used for informational purposes only by the customer. Skyworks assumes no responsibility for errors or omissions in these materials or the information contained herein. Skyworks may change its documentation, products, services, specifications or product descriptions at any time, without notice. Skyworks makes no commitment to update the materials or information and shall have no responsibility whatsoever for conflicts, incompatibilities, or other difficulties arising from any future changes.

No license, whether express, implied, by estoppel or otherwise, is granted to any intellectual property rights by this document. Skyworks assumes no liability for any materials, products or information provided hereunder, including the sale, distribution, reproduction or use of Skyworks products, information or materials, except as may be provided in Skyworks' Terms and Conditions of Sale.

THE MATERIALS, PRODUCTS AND INFORMATION ARE PROVIDED "AS IS" WITHOUT WARRANTY OF ANY KIND, WHETHER EXPRESS, IMPLIED, STATUTORY, OR OTHERWISE, INCLUDING FITNESS FOR A PARTICULAR PURPOSE OR USE, MERCHANTABILITY, PERFORMANCE, QUALITY OR NON-INFRINGEMENT OF ANY INTELLECTUAL PROPERTY RIGHT; ALL SUCH WARRANTIES ARE HEREBY EXPRESSLY DISCLAIMED. SKYWORKS DOES NOT WARRANT THE ACCURACY OR COMPLETENESS OF THE INFORMATION, TEXT, GRAPHICS OR OTHER ITEMS CONTAINED WITHIN THESE MATERIALS. SKYWORKS SHALL NOT BE LIABLE FOR ANY DAMAGES, INCLUDING BUT NOT LIMITED TO ANY SPECIAL, INDIRECT, INCIDENTAL, STATUTORY, OR CONSEQUENTIAL DAMAGES, INCLUDING WITHOUT LIMITATION, LOST REVENUES OR LOST PROFITS THAT MAY RESULT FROM THE USE OF THE MATERIALS OR INFORMATION, WHETHER OR NOT THE RECIPIENT OF MATERIALS HAS BEEN ADVISED OF THE POSSIBILITY OF SUCH DAMAGE.

Skyworks products are not intended for use in medical, lifesaving or life-sustaining applications, or other equipment in which the failure of the Skyworks products could lead to personal injury, death, physical or environmental damage. Skyworks customers using or selling Skyworks products for use in such applications do so at their own risk and agree to fully indemnify Skyworks for any damages resulting from such improper use or sale.

Customers are responsible for their products and applications using Skyworks products, which may deviate from published specifications as a result of design defects, errors, or operation of products outside of published parameters or design specifications. Customers should include design and operating safeguards to minimize these and other risks. Skyworks assumes no liability for applications assistance, customer product design, or damage to any equipment resulting from the use of Skyworks products outside of Skyworks' published specifications or parameters.

Skyworks, the Skyworks symbol, Sky5®, SkyOne®, SkyBlue™, Skyworks Green™, Clockbuilder®, DSPLL®, ISOModem®, ProSLIC®, and SiPHY® are trademarks or registered trademarks of Skyworks Solutions, Inc. or its subsidiaries in the United States and other countries. Third-party brands and names are for identification purposes only and are the property of their respective owners. Additional information, including relevant terms and conditions, posted at [www.skyworksinc.com](http://www.skyworksinc.com), are incorporated by reference.