



**Power Blade Products**

TE Internal #: 521986-2

TE Internal Description: POWER BLADE HSG 10P NYLON NATURAL

[View on TE.com >](#)

Terminals & Splices > Terminal Housings, Insulation Sleeves & Blocks > Crimp Terminal Housings

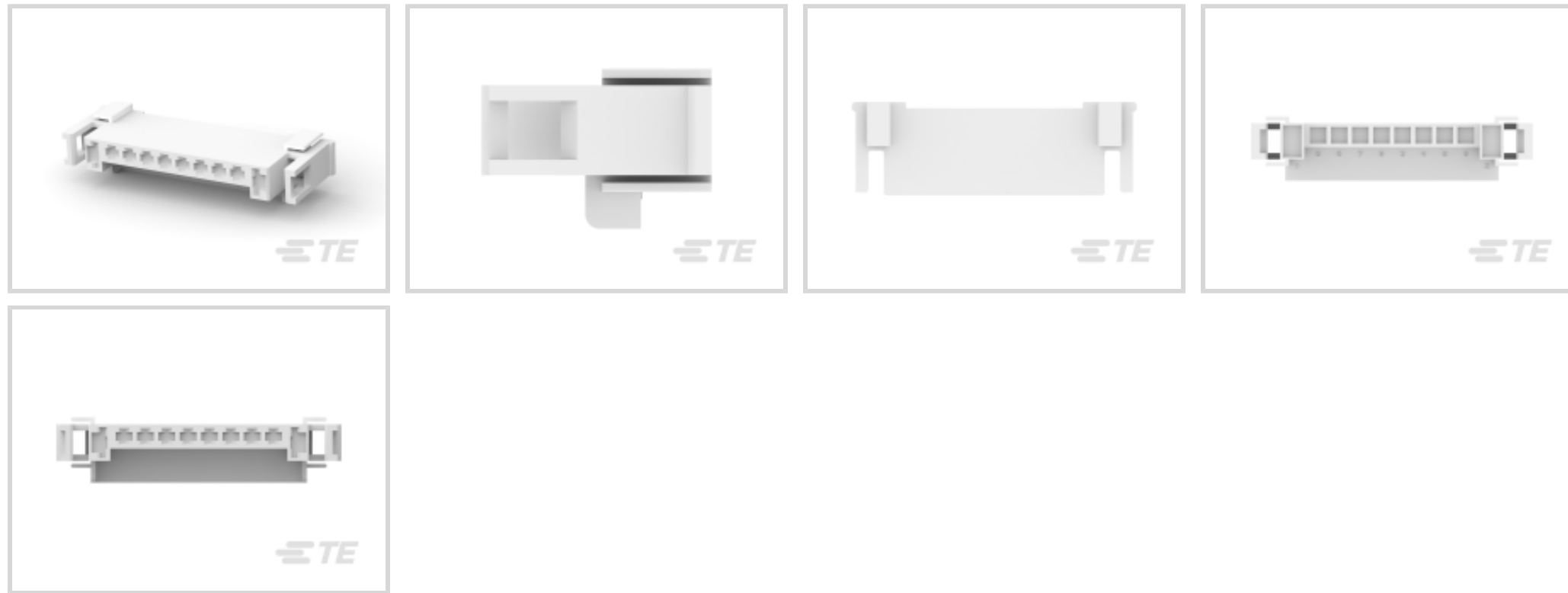

Terminal Type: **Receptacle**

Connector & Housing Type: **Receptacle**

Number of Positions: **10**

Terminal Orientation: **Straight**

UL Flammability Rating: **UL 94V-2**

**Features**

**Product Type Features**

Sealable	No
Connector System	Wire-to-Wire
Connector & Housing Type	Receptacle

**Configuration Features**

Number of Positions	10
---------------------	----

**Body Features**

Primary Product Color	Natural
-----------------------	---------

**Contact Features**

Terminal Type	Receptacle
Terminal Orientation	Straight
Contact Mating Retention	With

**Mechanical Attachment**

Mating Alignment Type	Polarization
Mating Retention Type	Latch

Mating Alignment	With
Connector Mounting Type	Cable Mount (Free-Hanging)

### Housing Features

Housing Material	Nylon 66
Centerline (Pitch)	5.59 mm[.22 in]

### Dimensions

Product Width	12.94 mm
Product Length	63.85 mm[2.513 in]

### Usage Conditions

Operating Temperature Range	-55 – 105 °C[-67 – 221 °F]
-----------------------------	----------------------------

### Industry Standards

UL Flammability Rating	UL 94V-2
------------------------	----------

### Packaging Features

Packaging Quantity	1
Packaging Method	Package

## Product Compliance

[For compliance documentation, visit the product page on TE.com>](#)

EU RoHS Directive 2011/65/EU	Compliant
EU ELV Directive 2000/53/EC	Not Yet Reviewed
China RoHS 2 Directive MIIT Order No 32, 2016	No Restricted Materials Above Threshold
EU REACH Regulation (EC) No. 1907/2006	Current ECHA Candidate List: JUNE 2023 (235) Candidate List Declared Against: JUL 2017 (174) SVHC > Threshold: Not Yet Reviewed
Halogen Content	Not Low Halogen - contains Br or Cl > 900 ppm.
Solder Process Capability	Not applicable for solder process capability

#### Product Compliance Disclaimer

This information is provided based on reasonable inquiry of our suppliers and represents our current actual knowledge based on the information they provided. This information is subject to change. The part numbers that TE has identified as EU RoHS compliant have a maximum concentration of 0.1% by weight in homogenous materials for lead, hexavalent chromium, mercury, PBB, PBDE, DBP, BBP, DEHP, DIBP, and 0.01% for cadmium, or qualify for an exemption to these limits as defined in the Annexes of Directive 2011/65/EU (RoHS2). Finished electrical and electronic equipment products will be CE marked as required by Directive 2011/65/EU. Components may not be CE marked. Additionally, the part

numbers that TE has identified as EU ELV compliant have a maximum concentration of 0.1% by weight in homogenous materials for lead, hexavalent chromium, and mercury, and 0.01% for cadmium, or qualify for an exemption to these limits as defined in the Annexes of Directive 2000/53/EC (ELV). Regarding the REACH Regulations, TE's information on SVHC in articles for this part number is still based on the European Chemical Agency (ECHA) 'Guidance on requirements for substances in articles' (Version: 2, April 2011), applying the 0.1% weight on weight concentration threshold at the finished product level. TE is aware of the European Court of Justice ruling of September 10th, 2015 also known as O5A (Once An Article Always An Article) stating that, in case of 'complex object', the threshold for a SVHC must be applied to both the product as a whole and simultaneously to each of the articles forming part of its composition. TE has evaluated this ruling based on the new ECHA "Guidance on requirements for substances in articles" (June 2017, version 4.0) and will be updating its statements accordingly.

## Also in the Series | Power Blade Products

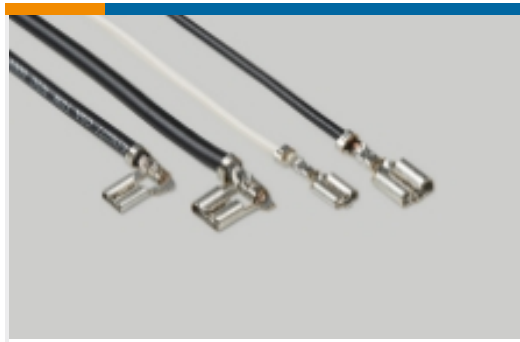

Quick Disconnects(1)

## Customers Also Bought

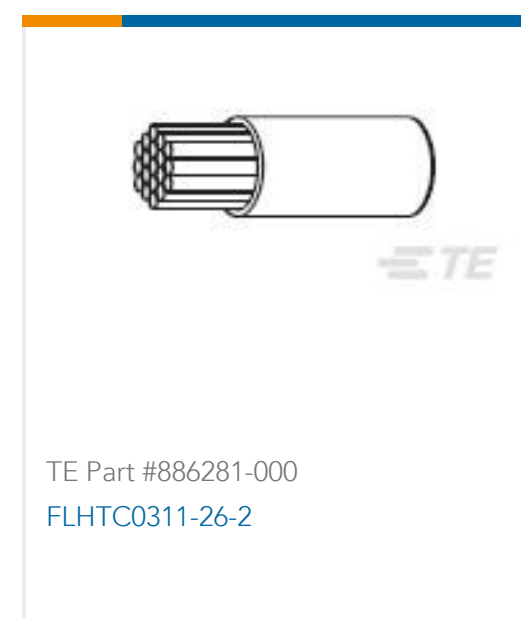



## Documents

### Product Drawings

[POWER BLADE HSG 10P NYLON NATURAL](#)

English

---

### CAD Files

[3D PDF](#)

3D

Customer View Model

[ENG\\_CVM\\_CVM\\_521986-2\\_D\\_c-521986-2-d.2d\\_dxf.zip](#)

English

Customer View Model

[ENG\\_CVM\\_CVM\\_521986-2\\_D\\_c-521986-2-d.3d\\_igs.zip](#)

English

Customer View Model

[ENG\\_CVM\\_CVM\\_521986-2\\_D\\_c-521986-2-d.3d\\_stp.zip](#)

English

By downloading the CAD file I accept and agree to the [Terms and Conditions](#) of use.

---

### Product Specifications

[Application Specification](#)

English

---

### Agency Approvals

[UL Report](#)

English