

Actuator

51-
252.0268

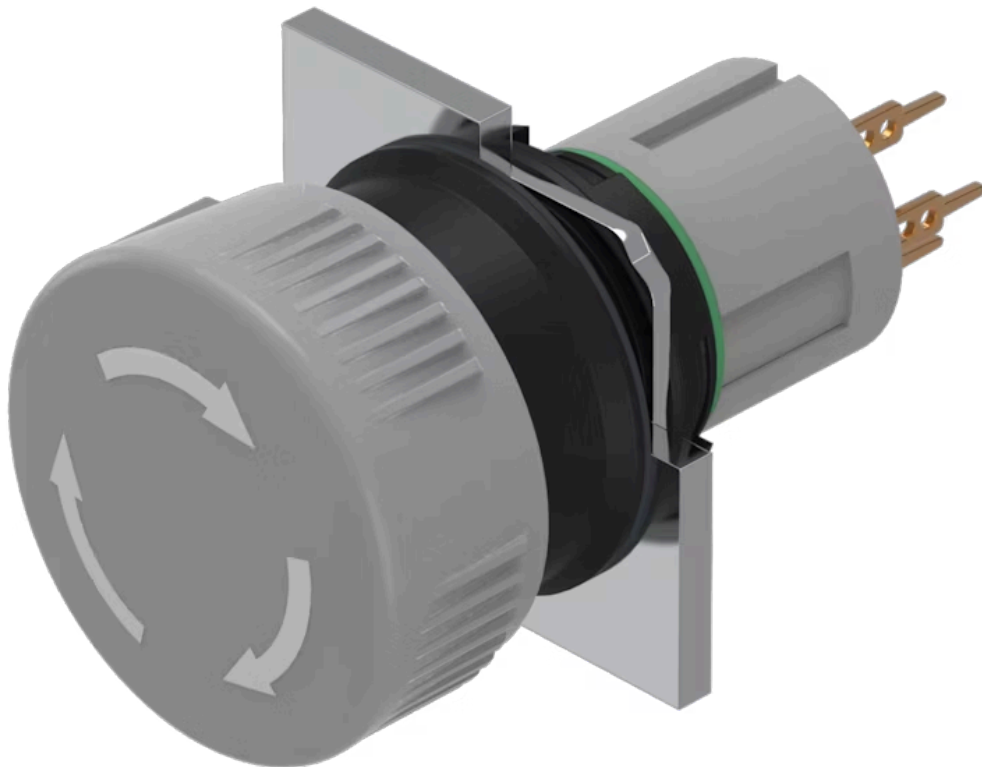

<https://eao.com/p/51-252.0268>

Your product:



51-252.0268 Actuator

FRONT

Front dimension: Ø 24,5 mm

MOUNTING

Design: raised

OPERATING-/INDICATION PART

Lens illumination: non illuminative

Lens shape: mushroom-head

Lens colour: Grey

Lens material: Plastic

Lens optics: opaque

ELECTRICAL CHARACTERISTICS

Contacts: 2 NC

Switching voltage and switching current: 100 mA at 42 VAC/VDC

MECHANICAL CHARACTERISTIC

Switching system: This low-level switching element was designed for switching low powers in electronic circuits. The mechanism assures reliable switching of loads ranging from a few $\mu\text{A}/\mu\text{V}$ up to 100 mA/ 42 VAC/DC. Single-break momentary contact, as normally open or normally closed with 4 independent points of contact. 2 momentary contacts per switching element; combination of normally open and normally closed is possible. Special features are the long life, extremely short rebound time and stable contact resistance.

Tightening torque: Fixing nut max. 0.5 Nm

Operating Travel:	3 mm
Operating force:	1,8 ... 3,5 N
Mechanical lifetime:	1 Mio. cycles of operation
Switching action:	Maintained
Terminal:	Universal terminal, 2 x 0.5 mm
Contact material:	Gold
Weight:	0.011 kg
Switching system:	Low-level element

AMBIENT CONDITION

Operating temperature:	- 25 °C ... + 55 °C
Storage temperature:	- 40 °C ... + 85 °C
IP front protection:	IP65, according to DIN EN 60529

OTHER

Short Description: Actuator, Ø 24,5 mm, mushroom-head, non illuminative, Grey, Plastic, opaque, 2 NC, Maintained, Universal terminal, 2 x 0.5 mm, IP65, according to DIN EN 60529

Hints: Marking arrows

Housing colour: Black

Mounting cut-outs:

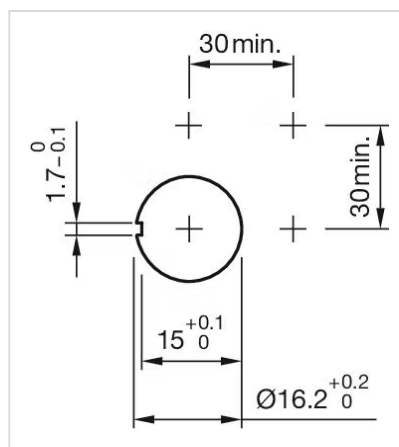

Wiring diagrams:

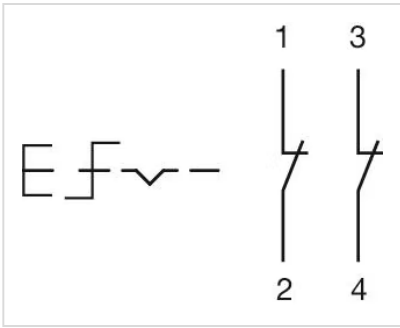

Dimension drawings:

