

Rubycon **HYBRID POLYMER CAPACITORS** **PFV**

PFV SERIES

UPGRADE



- Surface Mount Type
- Load life : 4000 hours at 125°C
- AEC-Q200 , 85°C/85% RH , RoHS Compliant

◆SPECIFICATIONS

Item	Characteristics														
Temperature Range	-55~+125°C														
Rated Voltage Range	25~80Vdc														
Capacitance Tolerance	±20% (20°C, 120Hz)														
Leakage Current (MAX)	I=0.01CV or 3μA After 2 minutes (whichever is greater.) I=(μ A) Leakage Current C=(μ F) Capacitance V=(Vdc) Rated Voltage														
Dissipation Factor (MAX)	<table border="1"> <thead> <tr> <th>(Vdc) Rated Voltage</th> <th>25</th> <th>35</th> <th>50</th> <th>63</th> <th>80</th> <th>(20°C, 120Hz)</th> </tr> </thead> <tbody> <tr> <td>tan δ</td> <td>0.14</td> <td>0.12</td> <td>0.10</td> <td>0.08</td> <td>0.08</td> <td></td> </tr> </tbody> </table>	(Vdc) Rated Voltage	25	35	50	63	80	(20°C, 120Hz)	tan δ	0.14	0.12	0.10	0.08	0.08	
(Vdc) Rated Voltage	25	35	50	63	80	(20°C, 120Hz)									
tan δ	0.14	0.12	0.10	0.08	0.08										
Endurance (Life)	After applying rated voltage with rated ripple current for 4000 hours at 125°C, the capacitors shall meet the following Criteria.														
Biased Humidity/Temperature 85°C/85%RH	After applying rated voltage for 2000 hours at 85°C and humidity of 85%, the capacitors shall meet the following Criteria .														
Criteria	<table border="1"> <tbody> <tr> <td>Capacitance Change</td> <td>Within ±30% of the initial value.</td> </tr> <tr> <td>Dissipation Factor</td> <td>Not more than 200% of the specified value.</td> </tr> <tr> <td>ESR</td> <td>Not more than 200% of the specified value.</td> </tr> <tr> <td>Leakage Current</td> <td>Not more than the specified value.</td> </tr> </tbody> </table>	Capacitance Change	Within ±30% of the initial value.	Dissipation Factor	Not more than 200% of the specified value.	ESR	Not more than 200% of the specified value.	Leakage Current	Not more than the specified value.						
Capacitance Change	Within ±30% of the initial value.														
Dissipation Factor	Not more than 200% of the specified value.														
ESR	Not more than 200% of the specified value.														
Leakage Current	Not more than the specified value.														
Low Temperature Stability Impedance Ratio (MAX)	Z(-55°C)/Z(+20°C) ≤ 2.0 (100kHz) Z(-25°C)/Z(+20°C) ≤ 1.5														

◆PART NUMBER CONSTRUCTION

□□□	PFV	□□□	M	□□□	φDxL
Rated Voltage	Series	Capacitance	Capacitance Tolerance	Option	Case Size

*Specifications subject to change without notice.

Rubycon **HYBRID POLYMER CAPACITORS** **PFV**

◆ DIMENTIONS

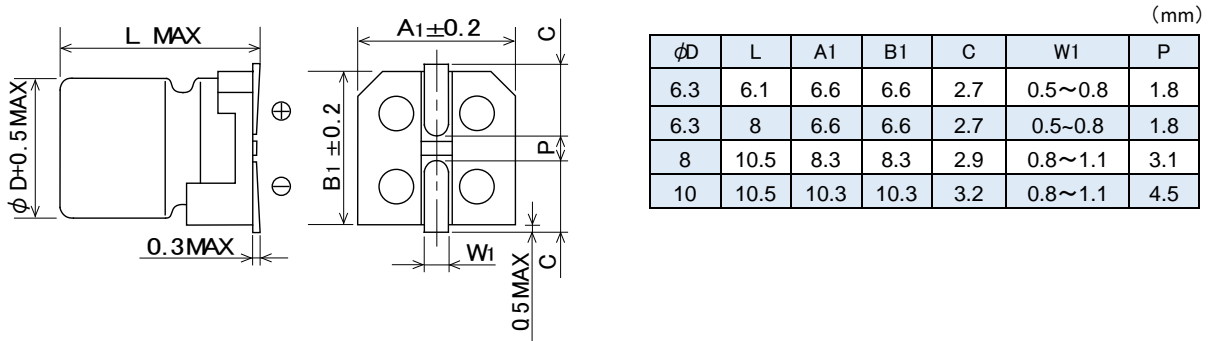

◆ Standard size

Rated Voltage (V)	Capacitance (μ F)	Size φ D × L (mm)	Dissipation Factor(MAX) 120Hz,20°C	Leakage Current (μ A/2min)	E.S.R (mΩ MAX)		Rated Ripple Current (mArms/125°C,100kHz)
					20°C,100kHz	-40°C,10kHz	
25	56	6.3×6.1	0.14	14.0	50	75	900
	100	6.3×8	0.14	25.0	30	45	1400
	220	8×10.5	0.14	55.0	27	41	1600
	330	10×10.5	0.14	82.5	20	30	2000
35	47	6.3×6.1	0.12	16.4	60	90	900
	68	6.3×8	0.12	23.8	35	53	1400
	150	8×10.5	0.12	52.5	27	41	1600
	270	10×10.5	0.12	94.5	20	30	2000
50	22	6.3×6.1	0.10	11.0	80	120	750
	33	6.3×8	0.10	16.5	40	60	1100
	68	8×10.5	0.10	34.0	30	45	1250
	100	10×10.5	0.10	50.0	28	42	1600
63	10	6.3×6.1	0.08	6.3	120	180	700
	22	6.3×8	0.08	13.8	80	120	900
	33	8×10.5	0.08	20.8	40	60	1100
	56	10×10.5	0.08	35.3	30	45	1400
NEW 80	22	8×10.5	0.08	17.6	45	68	1100
	39	10×10.5	0.08	31.2	35	53	1200

◆ FREQUENCY CORRECTION COEFFICIENT FOR RIPPLE CURRENT

f (Hz) Frequency	120	1k	10k	100k≤
Coefficient	0.05	0.30	0.70	1.00

*Specifications subject to change without notice.