Power Distribution Tap

1. SCOPE

1.1. Content

This specification covers performance, tests and quality requirements for TE Connectivity (TE) power distribution taps. These taps are available in .100 X .300 and .125 X .250 inch centerlines. The .125 X .250 taps are available in 6 and 10 position while the .100 X .300 tap is available in 10 position only.

1.2. Definitions

For the purpose of this specification, the following definitions shall apply.

- Power Distribution Tap: A printed circuit board mounted device intended as an interface between printed circuit board and power leads.
- ACTION PIN* Contacts: Pins used on power distribution tap for distributing current to printed circuit board.

1.3. Qualification

When tests are performed on the subject product line, procedures specified in Figure 1 shall be used. All inspections shall be performed using applicable inspection plan and product drawing.

1.4. Qualification Test Results

Successful qualification testing on the subject product line was completed in Jan93. The Qualification Test Report number for this testing is 501-215. This documentation is on file at and available from Engineering Practices and Standards (EPS).

2. APPLICABLE DOCUMENTS

The following documents constitute a part of this specification to the extent specified herein. Unless otherwise specified, the latest edition of the document applies. In the event of conflict between the requirements of this specification and the product drawing, the product drawing shall take precedence. In the event of conflict between the requirements of this specification and the referenced documents, this specification shall take precedence.

2.1. TE Documents

- 109 Series: Test Specifications as indicated in Figure 1
- 114-11000: Application Specification (Power Distribution Taps)
- 501-215: Qualification Test Report (Power Distribution Tap)

3. REQUIREMENTS

3.1. Design and Construction

Product shall be of the design, construction and physical dimensions specified on the applicable product drawing.

3.2. Materials

- Contact: Copper alloy 725
- Housing: Thermoplastic, UL94V0

3.3. Ratings

- Current: See Figure 2 for applicable current carrying capability
- Temperature: -55 to 85°C

3.4. Performance and Test Description

Product is designed to meet the electrical, mechanical and environmental performance requirements specified in Figure 1. Unless otherwise specified, all tests shall be performed at ambient environmental conditions per Test Specification 109-1.

3.5. Test Requirements and Procedures Summary

Test Description	Requirement	Procedure									
Examination of product.	Meets requirements of product drawing and Application Specification 114-11000.	Visual, dimensional and functional per applicable quality inspection plan.									
ELECTRICAL											
Termination resistance, specified current.	<table border="1"> <thead> <tr> <th>Position</th> <th>Test Current (amperes)</th> <th>Resistance (milliohms) maximum</th> </tr> </thead> <tbody> <tr> <td>6</td> <td>15</td> <td>.5</td> </tr> <tr> <td>10</td> <td>25</td> <td>.4</td> </tr> </tbody> </table>	Position	Test Current (amperes)	Resistance (milliohms) maximum	6	15	.5	10	25	.4	TE Spec 109-25. Measure potential drop of mated contacts assembled in housing. Calculate resistance. See Figure 7.
Position	Test Current (amperes)	Resistance (milliohms) maximum									
6	15	.5									
10	25	.4									
Termination resistance, dry circuit.	<table border="1"> <thead> <tr> <th>Position</th> <th>Resistance (milliohms maximum)</th> </tr> </thead> <tbody> <tr> <td>6</td> <td>.5</td> </tr> <tr> <td>10</td> <td>.4</td> </tr> </tbody> </table>	Position	Resistance (milliohms maximum)	6	.5	10	.4	TE Spec 109-3. Subject connectors to 1 ampere test current and millivolt test method.			
Position	Resistance (milliohms maximum)										
6	.5										
10	.4										
Current cycling.	See Note.	TE Spec 109-51. Subject mated contacts to 250 cycles at 31.25 amperes for 15 minutes ON and 15 minutes OFF.									
Temperature rise vs current.	30°C maximum temperature rise at specified current.	TE Spec 109-45-1. Measure temperature rise vs current. See Figures 2 and 5.									
MECHANICAL											
Random vibration.	No discontinuities greater than 10 microseconds. See Note.	TE Spec 109-21-5. Subject mated connectors to 16.91 G's rms for 20 minutes in each of 3 mutually perpendicular planes. See Figure 6.									
Board insertion force.	400 pounds maximum for 10 position. 240 pounds maximum for 6 position.	Measure force necessary to mount tap onto test board using proper mounting fixture per applicable Instruction Sheet. See Figures 4A and 4B.									

Figure 1 (continued)

Test Description	Requirement	Procedure
Board extraction force.	70 pounds minimum for 10 position. 42 pounds minimum for 6 position.	Measure force necessary to remove tap from test board.
Torque.	See Note.	Apply 9 inch pounds torque to tap screw terminal, hold 15 seconds and release.
ENVIRONMENTAL		
Thermal shock.	See Note.	TE Spec 109-22. Subject taps with wire in place to 500 cycles between -55 and 85°C.
Humidity-temperature cycling.	See Note.	TE Spec 109-23-4, Condition B. Subject taps with wire in place to 10 humidity-temperature cycles between 25 and 65°C at 95% RH.
Temperature life.	See Note.	TE Spec 109-43. Subject taps with wire in place to 85°C for 168 hours.

NOTE Shall meet visual requirements, show no physical damage and shall meet requirements of additional tests specified in Test Sequence in Figure 3.

Figure 1 (end)

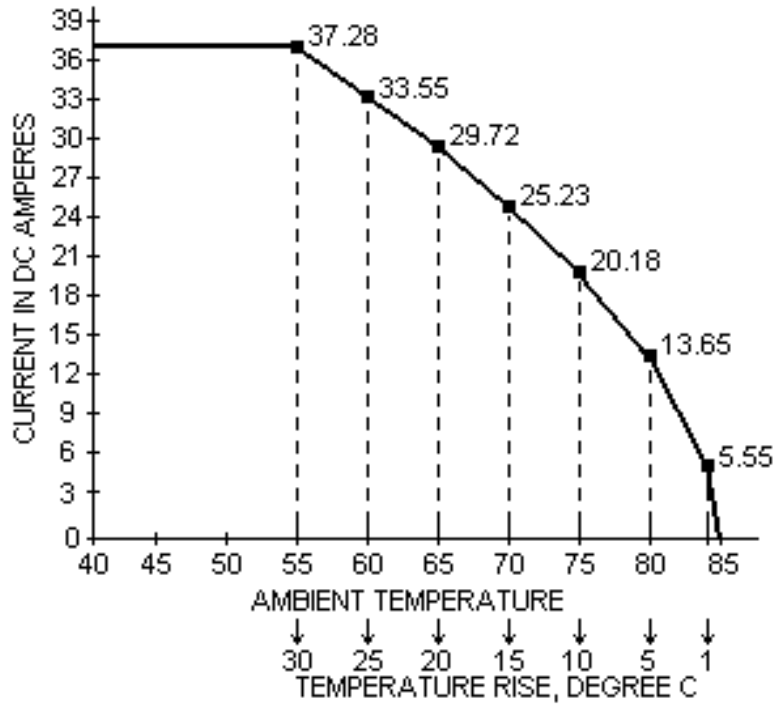

Figure 2A
Current Carrying Capability

Connector Size	Wire Size (AWG)	
	10	12
6 position	.91	.75
10 position	1.00	.82

NOTE

To determine acceptable current carrying capacity for connector size and wire gage indicated, use the Multiplication Factor (F) from the above chart and multiply times the Base Rated Current for single circuit at the maximum operating temperature shown in Figure 2A.

Figure 2B
Current Rating

3.6. Product Qualification And Requalification Test Sequence

Test or Examination	Test Group (a)			
	1	2	3	4
	Test Sequence (b)			
Examination of product	1	1	1	1
Termination resistance, specified current (c)	4,7,9,11	3,5,7,9		
Termination resistance, dry circuit				3,8
Current cycling		6		
Temperature rise vs current	5	10	2	4,9
Vibration	8			
Board insertion force	2			
Board extraction force	12			
Torque	3,10	2,8		2
Thermal shock		4		
Humidity-temperature cycling	6			5
Temperature life				6

- NOTE**
- (a) See paragraph 4.1.A.
 - (b) Numbers indicate sequence in which tests are performed.
 - (c) 25 amperes for 10 pin, 15 amperes for 6 pin.

Figure 3

4. QUALITY ASSURANCE PROVISIONS

4.1. Qualification Testing

A. Sample Selection

Taps shall be prepared in accordance with applicable Instruction Sheets and shall be selected at random from current production. Test groups 1 and 2 shall consist of 30 samples of 10 position, high profile, insulated power tap mounted to double sided printed circuit board. Test group 3 shall consist of 3 each of both 6 (.100 X .300) and 10 position (.125 X .250) taps (uninsulated, insulated low profile and insulated high profile) with and without anti-rotation embossments mounted to both single and double sided printed circuit boards. Test group 4 shall consist of 30 each of 10 position high profile and 6 position uninsulated taps mounted to double sided printed circuit boards. Test groups 1, 2 and 3 shall be wired with 12 AWG wire, test group 4 with 10 AWG wire. Wires shall be attached to taps using appropriate size PIDG terminals. Wire lengths shall meet minimum requirements of Test Specification 109-45. Printed circuit test boards shall be both single and double clad with .5 X .100 traces of 2 ounce copper.

B. Test sequence

Qualification inspection shall be verified by testing samples as specified in Figure 3.

4.2. Requalification Testing

If changes significantly affecting form, fit or function are made to the product or manufacturing process, product assurance shall coordinate requalification testing consisting of all or part of the original testing sequence as determined by development/product, quality and reliability engineering.

4.3. Acceptance

Acceptance is based upon verification that product meets the requirements of Figure 1. Failures attributed to equipment, test setup or operator deficiencies shall not disqualify the product. When product failure occurs, corrective action shall be taken and samples resubmitted for qualification. Testing to confirm corrective action is required prior to resubmittal.

4.4. Quality Conformance Inspection

The applicable quality inspection plan will specify acceptable quality sampling level to be used. Dimensional and functional requirements shall be in accordance with the applicable product drawing and this specification.

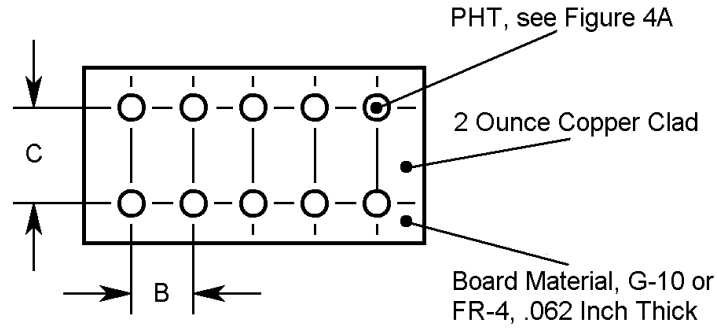

Tap Size	"B" Dimension	"C" Dimension
.125 X .250	.125	.250
.100 X .300	.100	.300

Hole Type	Drill Size	Drilled Hole Diameter $\pm .001$	Plating Thickness		Hole Diameter		Copper Hardness (Knoop)
			Copper	Tin-lead	After Plating	After Reflow	
A	1.15 mm	.0453	.001 to .003	.0003 min	.037 to .043	.036 to .043	150 max

Figure 4A
Printed Circuit Test Board

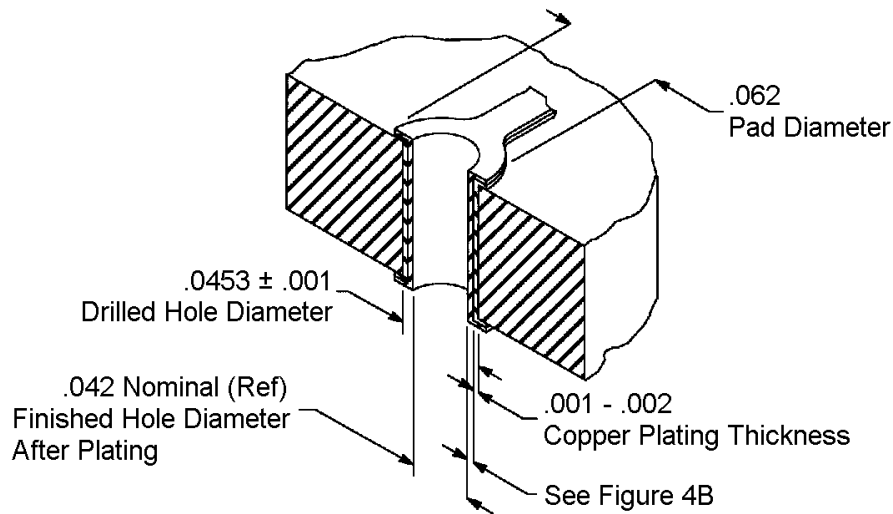

Surface Finish	
Thickness	Plating
.0002 - .0006	Hot Air Solder Leveling, Tin-Lead
.00002 Minimum	Immersion, Tin
.000008 - .00002	Organic Solderability Preservative
.000004 Minimum	Immersion, Silver

Figure 4B
Hole Dimensions

Thermocouple Placement
(Thermocouple attached using Loctite
Output conductive adhesive)

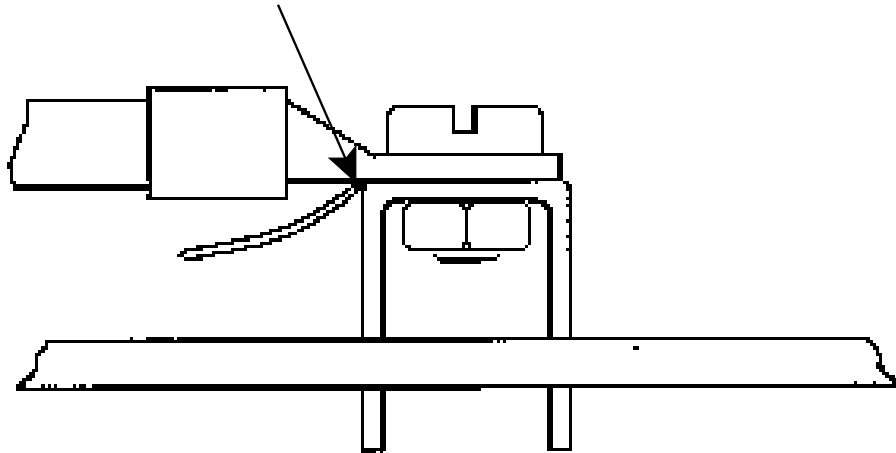

Figure 5
Thermocouple Mounting

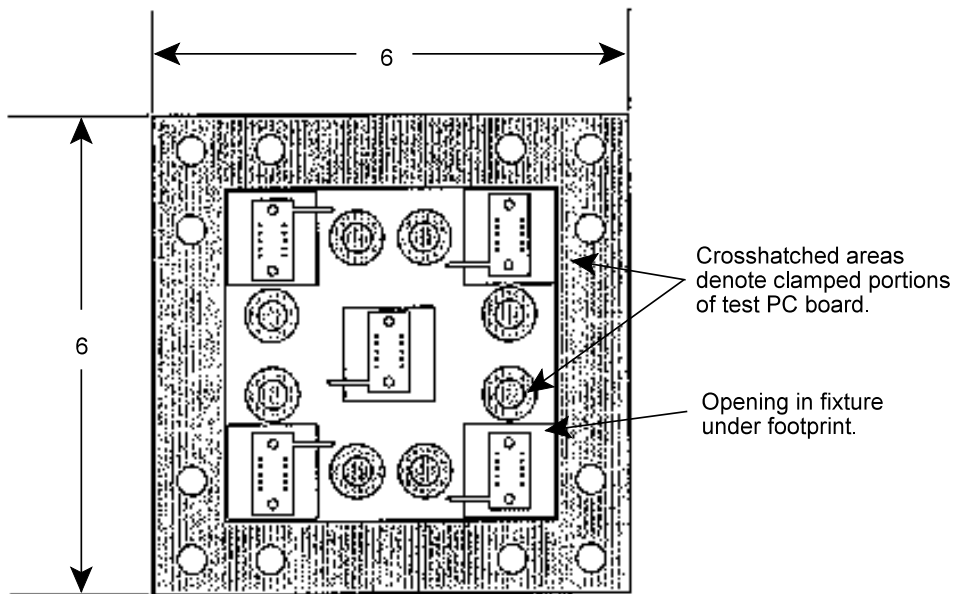

Figure 6
Vibration

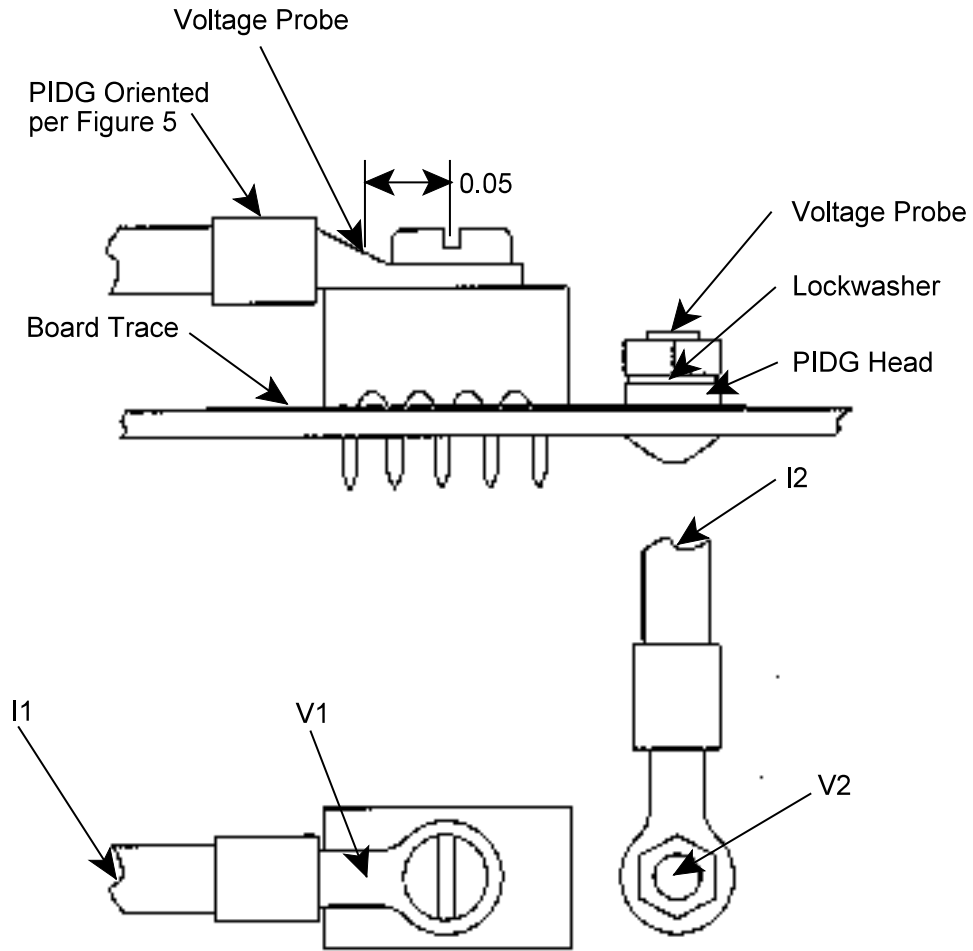

Figure 7
Termination Resistance Probe Locations