

【1. 適用範囲 SCOPE】

本仕様書は、_____ 殿 に納入する

Pico-Clasp 1.0 電線対基板 コネクタ (1列品 インナーロック 錫めっき品) について規定する。

This product specification covers the performance requirements for Pico-Clasp 1.0 WIRE TO BOARD CONNECTOR (SINGLE-ROW INNER LOCK TIN PLATING TYPE) series for _____ .

【2. 製品名称及び型番 PRODUCT NAME AND PART NUMBER】

製品名称 Product Name	製品型番 Part Number	図面番号 Drawing Number
リセ ターミナル (#28~32) Receptacle Terminal	501334 0*00	5013340000-SD PSD 000
リセ ハウジング Receptacle Housing	501330 ****	5013300000-SD PSD 000
ウエハーアセンブリ(バーティカル) エンボス梱包品(※) Embossed Tape Packaging of Wafer Assembly (Vertical)	501331 ***7	5013310000-SD PSD 000
ウエハーアセンブリ(ライトアングル) エンボス梱包品(※) Embossed Tape Packaging of Wafer Assembly (Right Angle) (※)	501568 ***7	5015680000-SD PSD 000

※：2~5極は乾燥剤入り、ハイバリア梱包となります。

(Besides 2~5circuits high barrier package including Desiccant)

*：図面参照 Refer to the drawing

取扱についてはコネクタ取扱説明書”5013300000-AS PS 000 を参照願います。

Instruction manual: Refer to 5013300000-AS PS 000

THIS DOCUMENT CONTAINS INFORMATION THAT IS PROPRIETARY TO MOLEX ELECTRONIC TECHNOLOGIES, LLC AND SHOULD NOT BE USED WITHOUT WRITTEN PERMISSION

REVISION DESCRIPTION	REVISED	PICO-CLASP1.0 WIRE TO BOARD CONNECTOR SINGLE ROW INNER LOCK TIN PLATING 製品仕様書					
CHANGE NO.	639978						
REVISED BY	MIKEDA01	DATE	2020/06/23	DOC TYPE	DOC TYPE DESCRIPTION	DOC PART	SERIES
REV APPR BY	KOMURAKAMI	DATE	2020/06/26	PS	ENGINEERING SPECIFICATION WORD	001	501330
INITIAL RELEASE				CUSTOMER	DOCUMENT NUMBER	REVISION	SHEET
INITIAL DRWN	AISHIKAWA	DATE	2019/03/27	GENERAL	5013300000-PS	B	1 OF 19
INITIAL APPR	SAKIYAMA	DATE	2019/09/17				

【 3. 定格及び適用電線 RATINGS AND APPLICABLE WIRES 】

項目 Item	規格 Standard	
最大許容電圧 Rated Voltage (MAX.)	100 V	
最大許容電流 Rated Current (MAX.)	AWG#28	1.0A
	AWG#30	1.0A
	AWG#32	0.8A
使用温度範囲*1*2*3 Ambient Temperature Range (Operating and Non-operating)	-40°C ~ +105°C 低温において氷結しないこと Not freeze to low temperature	
防湿梱包開梱後の保管条件*4 (2~5 極に適用) Storage condition after opening The Humidity Prevention package. (Applicable to 2~5 CIRCUIT)	温度 Temperature	-5°C~+35°C
	湿度 Humidity	70%R.H.以下(但し結露無きこと) 70%R.H.MAX.(No condensation)
	期間 Term	開梱後 48 時間 For 48 hours after opening the package

*1 : 基板実装後の無通電状態は、使用温度範囲が適用されます。

Non-operating connectors after reflow must follow the operating temperature range condition.

*2 : 通電による温度上昇分を含む。

This includes the terminal temperature rise generated by conducting electricity.

*3 : 適合電線、ケーブル等も本使用温度範囲を満足すること。

Applicable wires and cables must also meet the specified temperature range.

*4 : 開梱後の取り扱いについては、本書の注記事項を参照ください。

Please refer to 【8. NOTES】 after opening humidity prevention package.

参考許容電流 CURRENT DERATING REFERENCE INFORMATION

AWG	2-circuits	5-circuits	10-circuits	15-circuits
	Amps (A)	Amps (A)	Amps (A)	Amps (A)
28	2.0	1.5	1.0	1.0
30	1.5	1.0	1.0	1.0
32	1.5	1.0	0.8	0.8

1) 各電流値は参考となります。

Values are for REFERENCE ONLY

2) 閾値は温度上昇30°C以下としています。

Current deratings are based on not exceeding 30°C Temperature Rise.

3) 温度上昇の測定は圧着端子のバレル部にて実施しています。

Temperature Rise is measured in barrel area of crimp terminal.

4) 基板デザインにより温度上昇の結果が異なります。

PCB trace design can greatly affect temperature rise results.

5) 全極に通電し測定しています。

Data is for all circuits powered.

THIS DOCUMENT CONTAINS INFORMATION THAT IS PROPRIETARY TO MOLEX ELECTRONIC TECHNOLOGIES, LLC AND SHOULD NOT BE USED WITHOUT WRITTEN PERMISSION

REVISION DESCRIPTION	REVISED	PICO-CLASP1.0 WIRE TO BOARD CONNECTOR SINGLE ROW INNER LOCK TIN PLATING 製品仕様書					
CHANGE NO.	639978						
REVISED BY	MIKEDA01	DATE	2020/06/23	DOC TYPE	DOC TYPE DESCRIPTION	DOC PART	SERIES
REV APPR BY	KOMURAKAMI	DATE	2020/06/26	PS	ENGINEERING SPECIFICATION WORD	001	501330
INITIAL RELEASE				CUSTOMER	DOCUMENT NUMBER	REVISION	SHEET
INITIAL DRWN	AISHIKAWA	DATE	2019/03/27	GENERAL	5013300000-PS	B	2 OF 19
INITIAL APPR	SAKIYAMA	DATE	2019/09/17				

【4. 性能 PERFORMANCE】

4-1. 電気的性能 Electrical performance

項目 Item		条件 Test Condition	規格 Requirement
4-1-1	接触抵抗 Contact Resistance	コネクタを嵌合させ、開放電圧 20mV 以下、短絡電流 10mA 以下にて測定する。(JIS C5402-2-1) Mate connectors and measured by dry circuit, 20mV MAX., 10mA.MAX. (JIS C5402-2-1)	20 milliohms MAX.
4-1-2	絶縁抵抗 Insulation Resistance	コネクタを嵌合させ、隣接するターミナル間及びターミナル、アース間に、DC 500V を印加し測定する。(JIS C5402-3-1/MIL-STD-202 試験法 302) Mate connectors and apply 500V DC between adjacent terminal or ground. (JIS C5402-3-1/MIL-STD-202 Method 302)	100 Megohms MIN.
4-1-3	耐電圧 Dielectric Strength	コネクタを嵌合させ、隣接するターミナル間及びターミナル、アース間に、AC 300V (実効値) を 1 分間 印加する。 (JIS C5402-4-1/MIL-STD-202 試験法 301) Mate connectors and apply 300V AC(rms) for 1 minute between adjacent terminal or ground. (JIS C5402-4-1/MIL-STD-202 Method 301)	製品機能を損なう 異常なきこと No Damage on function
4-1-4	圧着部接触抵抗 Contact Resistance on Crimped Portion	ターミナルに適合電線を圧着し、開放電圧 20mV 以下、短絡電流 10mA 以下にて測定する。 Crimp the applicable wire to the terminal, measured by dry circuit, 20mV MAX., 10mA.MAX.	5.0 milliohms MAX.

THIS DOCUMENT CONTAINS INFORMATION THAT IS PROPRIETARY TO MOLEX ELECTRONIC TECHNOLOGIES, LLC AND SHOULD NOT BE USED WITHOUT WRITTEN PERMISSION

REVISION DESCRIPTION	REVISED	PICO-CLASP1.0 WIRE TO BOARD CONNECTOR SINGLE ROW INNER LOCK TIN PLATING 製品仕様書					
CHANGE NO.	639978						
REVISED BY	MIKEDA01	DATE	2020/06/23	DOC TYPE	DOC TYPE DESCRIPTION	DOC PART	SERIES
REV APPR BY	KOMURAKAMI	DATE	2020/06/26	PS	ENGINEERING SPECIFICATION WORD	001	501330
INITIAL RELEASE				CUSTOMER	DOCUMENT NUMBER	REVISION	SHEET
INITIAL DRWN	AISHIKAWA	DATE	2019/03/27	GENERAL	5013300000-PS	B	3 OF 19
INITIAL APPR	SAKIYAMA	DATE	2019/09/17				

4-2. 機械的性能 Mechanical Performance

項目 Item		条件 Test Condition		規格 Requirement
4-2-1	挿入力及び抜去力 Insertion and Withdrawal Force	毎分 25±3mm の速さで挿入、抜去を行う。なお、ロック機構は除去した状態で測定する。 Insert and withdraw connectors at the speed rate of 25±3 mm/minute. The measurement condition is that samples which removed the housing lock are used.		第 6 項参照 Refer to paragraph 6
4-2-2	圧着部引張強度 Crimping Pull out Force	圧着されたターミナルを治具に固定し、電線を軸方向に毎分 25±3mm の速さで引張る。 (JIS C5402-16-4) Fix the crimped terminal to the jig, apply axial pull out force on the wire at the speed rate of 25±3mm/minute. (JIS C5402-16-4)	AWG#28	9.8N{1.0kgf}MIN.
			AWG#30	4.9N{0.5kgf}MIN.
			AWG#32	3.0N{0.3kgf}MIN.
4-2-3	圧着端子挿入力 Crimp Terminal Insertion Force	圧着されたターミナルをハウジングに挿入する。 Insert the crimped terminal into the housing.		4.9N {0.5 kgf} MAX.
4-2-4	圧着端子保持力 Crimp Terminal Retention Force	ハウジングに装着した圧着されたターミナルを毎分 25±3mm の速さで軸方向に引張る。 Apply axial pull out force at the speed rate of 25±3 mm/minute on the crimped terminal assembled in the housing.		4.9N {0.5 kgf} MIN.
4-2-5	HDR 端子保持力 Header Terminal Retention Force	ウエハーに装着されたターミナルを毎分 25±3mm の速さで軸方向に引張る。 Apply axial pull out force at the speed rate of 25±3mm/minute on the terminal assembled in the wafer.		2.94N {0.3 kgf} MIN.
4-2-6	ハウジングロック強度 (ポジティブロック) Housing Lock Strength (Positive Lock)	コネクタを嵌合させ、軸方向に毎分 25±3mm の速さで引張る。 Mate connectors and apply axial pull out force at the speed rate of 25±3mm/minute.		19.6N{2 kgf} MIN.

THIS DOCUMENT CONTAINS INFORMATION THAT IS PROPRIETARY TO MOLEX ELECTRONIC TECHNOLOGIES, LLC AND SHOULD NOT BE USED WITHOUT WRITTEN PERMISSION

REVISION DESCRIPTION	REVISED	PICO-CLASP1.0 WIRE TO BOARD CONNECTOR SINGLE ROW INNER LOCK TIN PLATING 製品仕様書					
CHANGE NO.	639978						
REVISED BY	MIKEDA01	DATE	2020/06/23	DOC TYPE	DOC TYPE DESCRIPTION	DOC PART	SERIES
REV APPR BY	KOMURAKAMI	DATE	2020/06/26	PS	ENGINEERING SPECIFICATION WORD	001	501330
INITIAL RELEASE				CUSTOMER	DOCUMENT NUMBER	REVISION	SHEET
INITIAL DRWN	AISHIKAWA	DATE	2019/03/27	GENERAL	5013300000-PS	B	4 OF 19
INITIAL APPR	SAKIYAMA	DATE	2019/09/17				

4-3. 環境性能、その他 Environmental Performance and Others

項目 Item		条件 Test Condition	規格 Requirement	
4-3-1	繰り返し挿抜 Repeated Insertion / Withdrawal	1 分間 10 回以下の速さで、挿入、抜去を 30 回 繰り返す。 Insert and withdraw connectors 30 cycles repeatedly by rate of less than 10 cycles per minute.	接触抵抗 Contact Resistance	40 milliohms MAX.
4-3-2	温度上昇 Temperature Rise	コネクタを嵌合させ、全ての圧着端子を直 列に接続し最大許容電流で熱平衡に達した 時の温度上昇を測定する。(UL498) Mate connectors and all crimp terminals shall be connected in a direct series. The temperature rise shall be measured when the terminal reaches terminal equilibrium allowable current. (UL498)	温度上昇 Temperature Rise	30 °C MAX.
4-3-3	耐振動性 Vibration	コネクタを嵌合させ、DC 1mA 通電状態に て、嵌合軸を含む互いに垂直な 3 方向に 掃 引割合 10~55~10 Hz/分、全振幅 1.52mm の振動を各 2 時間 加える。(ケーブルは固 定すること) (JIS C 60068-2-6/MIL-STD-202 試験法 201) Mate connectors and subject to the following vibration conditions, for a period of 2 hours in each of 3 mutually perpendicular axes, passing DC 1mA during the test. (Fix the cable at test.) Amplitude : 1.52mm P-P Frequency : 10~55~10 Hz in 1 minute. Duration : 2 hours in each X.Y.Z.axes. (JIS C 60068-2-6/MIL-STD-202 Method 201)	外 観 Appearance	製品機能を損なう 異常なきこと No Damage on function
			接触抵抗 Contact Resistance	40 milliohms MAX.
			瞬 断 Discontinuity	1.0 microsecond MAX.

THIS DOCUMENT CONTAINS INFORMATION THAT IS PROPRIETARY TO MOLEX ELECTRONIC TECHNOLOGIES, LLC AND SHOULD NOT BE USED WITHOUT WRITTEN PERMISSION

REVISION DESCRIPTION	REVISED	PICO-CLASP1.0 WIRE TO BOARD CONNECTOR SINGLE ROW INNER LOCK TIN PLATING 製品仕様書					
CHANGE NO.	639978						
REVISED BY	MIKEDA01	DATE	2020/06/23	DOC TYPE	DOC TYPE DESCRIPTION	DOC PART	SERIES
REV APPR BY	KOMURAKAMI	DATE	2020/06/26	PS	ENGINEERING SPECIFICATION WORD	001	501330
INITIAL RELEASE				CUSTOMER	DOCUMENT NUMBER	REVISION	SHEET
INITIAL DRWN	AISHIKAWA	DATE	2019/03/27	GENERAL	5013300000-PS	B	5 OF 19
INITIAL APPR	SAKIYAMA	DATE	2019/09/17				

項目 Item		条件 Test Condition	規格 Requirement	
4-3-4	耐衝撃性 Mechanical Shock	コネクタを嵌合させ、DC 1mA 通電状態にて、テストパルス半周期、嵌合軸を含む互いに垂直な 6 方向 (±x 軸, ±y 軸, ±z 軸) に 490m/s ² { 50G }、作用時間 11ms の衝撃を各 3 回、合計 18 回加える。 (JIS C60068-2-27/MIL-STD-202 試験法 213) Mate connectors and subject to the following shock conditions. 3 shocks shall be applied 6 directions along 3 mutually perpendicular axes (±x, ±y, ±z, each), passing DC 1 mA current during the test. (Total of 18 shocks) Test pulse : Half Sine Peak value : 490 m/s ² (50 G) Duration : 11 ms (JIS C60068-2-27/MIL-STD-202 Method 213)	外観 Appearance	製品機能を損なう異常なきこと No Damage on function
			接触抵抗 Contact Resistance	40 milliohms MAX.
			瞬断 Discontinuity	1.0 microsecond MAX.
4-3-5	耐熱性 Heat Resistance	コネクタを嵌合させ、105±2°C の雰囲気中に 96 時間放置後取り出し、1~2 時間室温に放置する。 (JIS C60068-2-2/MIL-STD-202 試験法 108) Mate connectors and expose to 105±2°C for 96 hours. Upon completion of the exposure period, the test specimens shall be conditioned at ambient room conditions for 1 to 2 hours, after which the specified measurements shall be performed. (JIS C60068-2-2/MIL-STD-202 Method 108)	外観 Appearance	製品機能を損なう異常なきこと No Damage on function
			接触抵抗 Contact Resistance	40 milliohms MAX
4-3-6	耐寒性 Cold Resistance	コネクタを嵌合させ、-40±3°C の雰囲気中に 96 時間 放置後取り出し、1~2 時間 室温に放置する。(JIS C60068-2-1) Mate connectors and expose to -40±3°C for 96 hours. Upon completion of the exposure period, the test specimens shall be conditioned at ambient room conditions for 1 to 2 hours, after which the specified measurements shall be performed. (JIS C60068-2-1)	外観 Appearance	製品機能を損なう異常なきこと No Damage on function
			接触抵抗 Contact Resistance	40 milliohms MAX.

THIS DOCUMENT CONTAINS INFORMATION THAT IS PROPRIETARY TO MOLEX ELECTRONIC TECHNOLOGIES, LLC AND SHOULD NOT BE USED WITHOUT WRITTEN PERMISSION

REVISION DESCRIPTION	REVISED	PICO-CLASP1.0 WIRE TO BOARD CONNECTOR SINGLE ROW INNER LOCK TIN PLATING 製品仕様書					
CHANGE NO.	639978						
REVISED BY	MIKEDA01	DATE	2020/06/23	DOC TYPE	DOC TYPE DESCRIPTION	DOC PART	SERIES
REV APPR BY	KOMURAKAMI	DATE	2020/06/26	PS	ENGINEERING SPECIFICATION WORD	001	501330
INITIAL RELEASE				CUSTOMER	DOCUMENT NUMBER	REVISION	SHEET
INITIAL DRWN	AISHIKAWA	DATE	2019/03/27	GENERAL	5013300000-PS	B	6 OF 19
INITIAL APPR	SAKIYAMA	DATE	2019/09/17				

項目 Item		条件 Test Condition	規格 Requirement	
4-3-7	耐湿性 Humidity	コネクタを嵌合させ、60±2°C、相対湿度90~95%の雰囲気中に96時間放置後取り出し、1~2時間室温に放置する。 (JIS C60068-2-78/MIL-STD-202 試験法 103) Mate connectors and expose to 60±2°C, relative humidity 90 to 95% for 96 hours. Upon completion of the exposure period, the test specimens shall be conditioned at ambient room conditions for 1 to 2 hours, after which the specified measurements shall be performed. (JIS C60068-2-78/MIL-STD-202 Method 103)	外観 Appearance	製品機能を損なう異常なきこと No Damage on function
			接触抵抗 Contact Resistance	40 milliohms MAX.
			耐電圧 Dielectric Strength	4-1-3 項満足のこと Must meet 4-1-3
			絶縁抵抗 Insulation Resistance	10 Megohms MIN
4-3-8	温度サイクル Temperature Cycling	コネクタを嵌合させ、-55±3°Cに30分、+105±2°Cに30分。これを1サイクルとし、5サイクル繰返す。 但し、温度移行時間は5分以内とする。 試験後1~2時間室温に放置する。 (JIS C60068-2-14) Mate connectors and subject to the following conditions for 5 cycles. Upon completion of the exposure period, the test specimens shall be conditioned at ambient room conditions for 1 to 2 hours, after which the specified measurements shall be performed. 5 cycles of : a) - 55±3°C 30 minutes b) + 105±2°C 30 minutes Shift time : Within 5 minutes (JIS C60068-2-14)	外観 Appearance	製品機能を損なう異常なきこと No Damage on function
			接触抵抗 Contact Resistance	40 milliohms MAX.

THIS DOCUMENT CONTAINS INFORMATION THAT IS PROPRIETARY TO MOLEX ELECTRONIC TECHNOLOGIES, LLC AND SHOULD NOT BE USED WITHOUT WRITTEN PERMISSION

REVISION DESCRIPTION	REVISED	PICO-CLASP1.0 WIRE TO BOARD CONNECTOR SINGLE ROW INNER LOCK TIN PLATING 製品仕様書					
CHANGE NO.	639978						
REVISED BY	MIKEDA01	DATE	2020/06/23	DOC TYPE	DOC TYPE DESCRIPTION	DOC PART	SERIES
REV APPR BY	KOMURAKAMI	DATE	2020/06/26	PS	ENGINEERING SPECIFICATION WORD	001	501330
INITIAL RELEASE				CUSTOMER	DOCUMENT NUMBER	REVISION	SHEET
INITIAL DRWN	AISHIKAWA	DATE	2019/03/27	GENERAL	5013300000-PS	B	7 OF 19
INITIAL APPR	SAKIYAMA	DATE	2019/09/17				

項目 Item		条件 Test Condition	規格 Requirement	
4-3-9	塩水噴霧 Salt Spray	コネクタを嵌合させ、35±2°Cにて5±1%重量比の塩水を48±4時間噴霧し、試験後常温で水洗いした後、室温で乾燥させる。 (JIS C60068-2-11/MIL-STD-202 試験法 101) Mated connectors and expose to the following salt mist conditions. Upon completion of the exposure period, salt deposits shall be removed by a gentle wash or dip in running water, after which the specified measurements shall be performed. NaCl solution Concentration : 5±1 % Spray time : 48±4 hours Ambient temperature : 35±2 °C (JIS 60068-2-11/MIL-STD-202 Method 101)	外観 Appearance	製品機能を損なう異常なきこと No Damage on function
			接触抵抗 Contact Resistance	40 milliohms MAX.
4-3-10	耐亜硫酸ガス SO ₂ Gas	コネクタを嵌合させ、40±2°Cにて50±5ppmの亜硫酸ガス中に24時間放置する。 Mated connectors and expose to the conditions of 50±5ppm SO ₂ gas ambient temperature 40±2°C for 24 hours.	外観 Appearance	製品機能を損なう異常なきこと No Damage on function
			接触抵抗 Contact Resistance	40 milliohms MAX.
4-3-11	耐アンモニア性 NH ₃ Gas	コネクタを嵌合させ、濃度28%のアンモニア水を入れた容器中に40分間放置する。 (1Lに対して25mLの割合) Mated connectors and expose to the conditions of NH ₃ gas evaporating from 28% NH ₃ solution for 40 minutes. (Rate is 25ml per 1L)	外観 Appearance	製品機能を損なう異常なきこと No Damage on function
			接触抵抗 Contact Resistance	40 milliohms MAX.

THIS DOCUMENT CONTAINS INFORMATION THAT IS PROPRIETARY TO MOLEX ELECTRONIC TECHNOLOGIES, LLC AND SHOULD NOT BE USED WITHOUT WRITTEN PERMISSION

REVISION DESCRIPTION	REVISED	PICO-CLASP1.0 WIRE TO BOARD CONNECTOR SINGLE ROW INNER LOCK TIN PLATING 製品仕様書					
CHANGE NO.	639978						
REVISED BY	MIKEDA01	DATE	2020/06/23	DOC TYPE	DOC TYPE DESCRIPTION	DOC PART	SERIES
REV APPR BY	KOMURAKAMI	DATE	2020/06/26	PS	ENGINEERING SPECIFICATION WORD	001	501330
INITIAL RELEASE				CUSTOMER	DOCUMENT NUMBER	REVISION	SHEET
INITIAL DRWN	AISHIKAWA	DATE	2019/03/27	GENERAL	5013300000-PS	B	8 OF 19
INITIAL APPR	SAKIYAMA	DATE	2019/09/17				

項目 Item		条件 Test Condition	規格 Requirement	
4-3-12	はんだ付け性 Solder ability	ターミナルまたはピンをフラックスに浸し、端子先端より 0.5mm 迄、 245±3°C のはんだに 3±0.5 秒浸す。 Dip terminal or pin into flux, and immerse the area up to 0.5mm from the tip of terminal into solder molten at 245±3°C for 3±0.5 sec.	濡れ性 Solder Wetting	ピンホールや隙間なく浸漬面積の 95%以上 95% of immersed area must show no voids, pin holes.
4-3-13	はんだ耐熱性 Resistance to Soldering Heat	赤外線リフロー時 (Reflow by IR Reflow Machine) 第 7 項の推奨温度プロファイル条件にてリフローを行う。 Using the reflow profile condition below paragraph 7, the product was reflowed.	外観 Appearance	端子ガタ、割れ等異常なきこと No Damage
		手はんだ時 (Reflow by Manual Soldering iron) 端子先端、金具先端より 0.2mm の位置まで、370~400°C のはんだゴテにて 3±1 秒加熱する。但し、異常な加圧のないこと。 Using a soldering iron (370~400°C for 3±1 seconds) heat up the area 0.2mm from the tip of the solder tails and fitting nails. However, do not apply excessive pressure to either the terminals or fitting nails.		

() : 参考規格 Reference Standard
{ } : 参考単位 Reference Unit

* 各項目の評価サンプルは、製品図面に記載されている推奨基板レイアウト、推奨メタルマスクにて実装しています。リフロー条件は第 7 項の推奨温度プロファイルにて実装しております。はんだペーストは、無鉛はんだ (Sn-3Ag-0.5Cu) を使用しています。

The evaluation samples of each specification test are reflowed according to the recommended Print Circuit Board layout and the recommended stencil thickness specified in the sales drawing. The reflow conditions followed are specified in the reflow profile in paragraph 7. Lead free solder (Sn-3Ag-0.5Cu) was used as the soldering paste.

THIS DOCUMENT CONTAINS INFORMATION THAT IS PROPRIETARY TO MOLEX ELECTRONIC TECHNOLOGIES, LLC AND SHOULD NOT BE USED WITHOUT WRITTEN PERMISSION

REVISION DESCRIPTION	REVISED	PICO-CLASP1.0 WIRE TO BOARD CONNECTOR SINGLE ROW INNER LOCK TIN PLATING 製品仕様書					
CHANGE NO.	639978						
REVISED BY	MIKEDA01	DATE	2020/06/23	DOC TYPE	DOC TYPE DESCRIPTION	DOC PART	SERIES
REV APPR BY	KOMURAKAMI	DATE	2020/06/26	PS	ENGINEERING SPECIFICATION WORD	001	501330
INITIAL RELEASE				CUSTOMER	DOCUMENT NUMBER	REVISION	SHEET
INITIAL DRWN	AISHIKAWA	DATE	2019/03/27	GENERAL	5013300000-PS	B	9 OF 19
INITIAL APPR	SAKIYAMA	DATE	2019/09/17				

【5. 外観形状、寸法及び材質 PRODUCT SHAPE, DIMENSIONS AND MATERIALS】

5-1. 製品寸法及び材質 Dimensions and materials of product.

図面参照 Refer to the drawing.

【6. 挿入力及び抜去力 INSERTION / WITHDRAWAL FORCE】

ロック形状 Lock Shape	極数 No. of CKT	単位 UNIT	挿入力 (最大値) Insertion (MAX.)			抜去力 (最小値) Withdrawal (MIN.)		
			初回 1st	6回目 6th	30回目 30th	初回 1st	6回目 6th	30回目 30th
フリクション ロック Friction Lock	2	N {kgf}	15.7 {1.6}	15.7 {1.6}	15.7 {1.6}	2.8 {0.29}	1.9 {0.19}	1.9 {0.19}
	3	N {kgf}	18.6 {1.9}	18.6 {1.9}	18.6 {1.9}	3.0 {0.31}	2.1 {0.21}	2.1 {0.21}
	4	N {kgf}	21.6 {2.2}	21.6 {2.2}	21.6 {2.2}	3.2 {0.33}	2.3 {0.23}	2.3 {0.23}
	5	N {kgf}	24.5 {2.5}	24.5 {2.5}	24.5 {2.5}	3.4 {0.35}	2.5 {0.25}	2.5 {0.25}
ポジティブ ロック Positive Lock	6	N {kgf}	17.6 {1.8}	17.6 {1.8}	17.6 {1.8}	1.2 {0.12}	1.2 {0.12}	1.2 {0.12}
	7	N {kgf}	20.6 {2.1}	20.6 {2.1}	20.6 {2.1}	1.4 {0.14}	1.4 {0.14}	1.4 {0.14}
	8	N {kgf}	23.5 {2.4}	23.5 {2.4}	23.5 {2.4}	1.6 {0.16}	1.6 {0.16}	1.6 {0.16}
	9	N {kgf}	26.5 {2.7}	26.5 {2.7}	26.5 {2.7}	1.7 {0.18}	1.7 {0.18}	1.7 {0.18}
	10	N {kgf}	29.4 {3.0}	29.4 {3.0}	29.4 {3.0}	2.0 {0.20}	2.0 {0.20}	2.0 {0.20}
	11	N {kgf}	32.3 {3.3}	32.3 {3.3}	32.3 {3.3}	2.2 {0.22}	2.2 {0.22}	2.2 {0.22}
	12	N {kgf}	35.3 {3.6}	35.3 {3.6}	35.3 {3.6}	2.4 {0.24}	2.4 {0.24}	2.4 {0.24}
	13	N {kgf}	38.2 {3.9}	38.2 {4.5}	38.2 {4.5}	2.5 {0.26}	2.5 {0.26}	2.5 {0.26}
	14	N {kgf}	41.2 {4.2}	41.2 {4.2}	41.2 {4.2}	2.7 {0.28}	2.7 {0.28}	2.7 {0.28}
	15	N {kgf}	44.1 {4.5}	44.1 {4.5}	44.1 {4.5}	2.9 {0.30}	2.9 {0.30}	2.9 {0.30}

※ ポジティブロックはロックを解除して測定 Released positive lock, and measure.

{ } : 参考単位 Reference Unit

THIS DOCUMENT CONTAINS INFORMATION THAT IS PROPRIETARY TO MOLEX ELECTRONIC TECHNOLOGIES, LLC AND SHOULD NOT BE USED WITHOUT WRITTEN PERMISSION

REVISION DESCRIPTION	REVISED	PICO-CLASP1.0 WIRE TO BOARD CONNECTOR SINGLE ROW INNER LOCK TIN PLATING 製品仕様書							
CHANGE NO.	639978								
REVISED BY	MIKEDA01	DATE	2020/06/23	DOC TYPE	DOC TYPE DESCRIPTION		DOC PART	SERIES	
REV APPR BY	KOMURAKAMI	DATE	2020/06/26	PS	ENGINEERING SPECIFICATION WORD		001	501330	
INITIAL RELEASE				CUSTOMER		DOCUMENT NUMBER		REVISION	SHEET
INITIAL DRWN	AISHIKAWA	DATE	2019/03/27	GENERAL		5013300000-PS		B	10 OF 19
INITIAL APPR	SAKIYAMA	DATE	2019/09/17						
TEMPLATE: 2090580003-PPS-A4 Rev A2 2020/04/05									

【 7. 赤外線リフロー条件 INFRARED REFLOW CONDITION 】

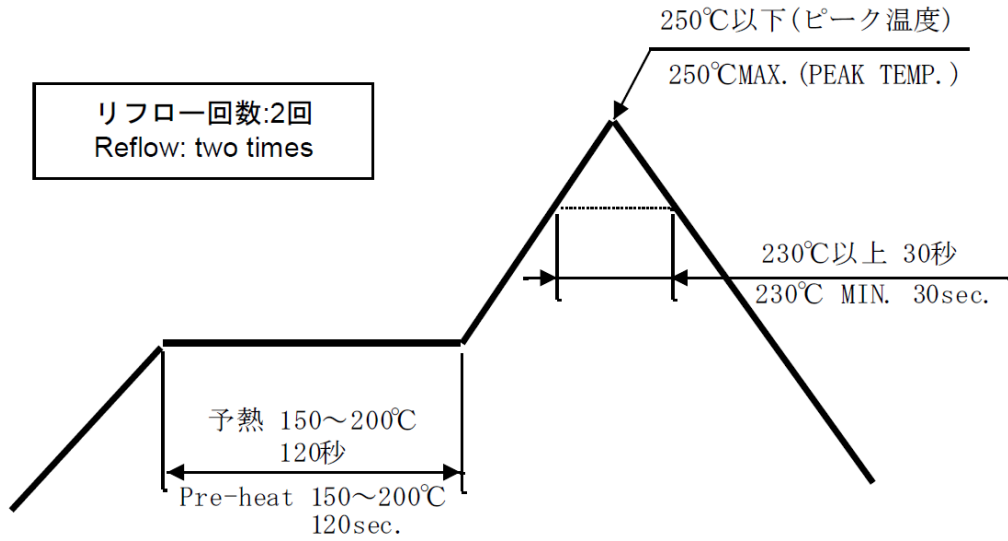

温度条件グラフ
TEMPERATURE CONDITION GRAPH
(はんだ接合部の基板表面にて測定)

(Temperature is measured at the soldering area on the surface of PCB)

注記：本リフロー条件に関しては、リフロー装置及び基板などにより条件が異なりますので事前に実装評価(リフロー評価)の御確認を御願致します。
端子テール部、ネイル部が変色する場合がございますが、はんだ付け性には問題ありません。

NOTE : Please check the mount condition (reflow soldering condition) by your own devices beforehand, because the condition changes by the soldering devices, printed circuit boards (PCB), and so on. Although tail of terminal and nail may discolors, a solderability does not have a problem.

THIS DOCUMENT CONTAINS INFORMATION THAT IS PROPRIETARY TO MOLEX ELECTRONIC TECHNOLOGIES, LLC AND SHOULD NOT BE USED WITHOUT WRITTEN PERMISSION

REVISION DESCRIPTION	REVISED	PICO-CLASP1.0 WIRE TO BOARD CONNECTOR SINGLE ROW INNER LOCK TIN PLATING 製品仕様書					
CHANGE NO.	639978						
REVISED BY	MIKEDA01	DATE	2020/06/23	DOC TYPE	DOC TYPE DESCRIPTION	DOC PART	SERIES
REV APPR BY	KOMURAKAMI	DATE	2020/06/26	PS	ENGINEERING SPECIFICATION WORD	001	501330
INITIAL RELEASE				CUSTOMER	DOCUMENT NUMBER	REVISION	SHEET
INITIAL DRWN	AISHIKAWA	DATE	2019/03/27	GENERAL	5013300000-PS	B	11 OF 19
INITIAL APPR	SAKIYAMA	DATE	2019/09/17				

【 8. 注記 NOTES.】

- 外観について Externals -

1. 本製品のプラスチック部に黒点、気泡等が確認される場合や色合いが異なる場合（経年変化によるハウジングの変色を含む）が御座いますが、製品性能に影響は御座いません。
There is no influence in the product performance though the black spot or bubble etc. might be confirmed to the plastic part of this product and the shade might be different (discoloration by secular distortion etc.).
2. 本製品のハウジング及びめっき表面に多少の傷が確認される場合がありますが、製品性能に問題御座いません。
A few scratches may be confirmed to the surface of the housing and the plating of this product, however, There is no problem in the product performance.
3. 本製品はネイルに錫めっきを使用している為、外観に摺動痕がつく場合が御座いますが、製品性能に影響は御座いません。
The wound of friction might adhere to externals because the tin plating is used for nail. But there is no influence in the product performance.
4. 本製品のプラスチック部が紫外線により変色する場合がありますが、製品性能には問題御座いません。
Discoloration of the plastic part of this product can result from exposure to ultraviolet light. There is no problem in the product performance.

- 実装について Mounting -

5. 条件に関しては、実装条件（大気/N₂リフロー、温度プロファイル、はんだペースト、メタルマスク板厚・開口率、基板パターンレイアウト、実装基板種別などの種々の要素）により条件が異なりますので、必ずご使用前に、顧客様のご使用環境で事前に実装評価（リフロー評価）を実施願います。実装条件によっては、接点部へのはんだ上がりやフラックス上りが発生するなど製品性能に影響を及ぼす場合があります。
Please make sure to do test run under the mounting condition (reflow soldering condition) on your own devices before use because reflow condition may change due to the local condition (Air / N₂ reflow / temperature profile / solder paste, stencil thickness / aperture rate / pattern layout of PCB / types of PCB / and other factors). Depending on the mounting condition, product's performance might be influenced by occurrence of solder-wicking or flux wicking at contact area.
6. 本品の一般性能確認はガラスエポキシ基板にて実施していますので、フレキシブル基板等の特殊な基板へ実装してご使用の際は、別途ご相談願います。
It is necessary to consult separately when mount product on a special PCB or FPC.
7. 弊社の推奨基板パターン寸法を変更して設計を行なう際は、致命的な不良の原因にもなりますのであらかじめご相談ください。
In the case of changing our recommended board pattern size and designing, please consult in advance because it may cause a fatal defect.
8. はんだ実装部の未はんだは、ターミナル脱落、ピン間ショート、ターミナル座屈、またコネクタ基板からの外れが懸念されます。従って全てのターミナルテール部及び、ネイル部にはんだ付けを行ってください。
If you leave any soldering area on this product open, there may be the possibility of a missing terminal short circuiting between pins, terminal buckling or the potential for the connectors to come off of the PCB. Therefore, please solder all of the terminals and fitting nails on the PCB.

THIS DOCUMENT CONTAINS INFORMATION THAT IS PROPRIETARY TO MOLEX ELECTRONIC TECHNOLOGIES, LLC AND SHOULD NOT BE USED WITHOUT WRITTEN PERMISSION

REVISION DESCRIPTION	REVISED	PICO-CLASP1.0 WIRE TO BOARD CONNECTOR SINGLE ROW INNER LOCK TIN PLATING 製品仕様書					
CHANGE NO.	639978						
REVISED BY	MIKEDA01	DATE	2020/06/23	DOC TYPE	DOC TYPE DESCRIPTION	DOC PART	SERIES
REV APPR BY	KOMURAKAMI	DATE	2020/06/26	PS	ENGINEERING SPECIFICATION WORD	001	501330
INITIAL RELEASE				CUSTOMER	DOCUMENT NUMBER	REVISION	SHEET
INITIAL DRWN	AISHIKAWA	DATE	2019/03/27	GENERAL	5013300000-PS	B	12 OF 19
INITIAL APPR	SAKIYAMA	DATE	2019/09/17				
TEMPLATE: 2090580003-PPS-A4 Rev A2 2020 / 04 / 05							

9. 実装機によってコネクタに負荷が加わると変形、破損する場合がありますので事前にご確認ください。
If there is accidental contact with the connectors while it is going through the reflow machine, there may be deformation or damage caused to the connectors. Please check to prevent this.
10. 基板実装前後に端子及びネイルに触らないでください。
Please do not touch the terminals and fitting nails before or after mounted the connectors onto the connectors onto the PCB.
11. 基板実装後に基板を直接積み重ねない様に注意してください。
Please do not stack the PCB directly after mounted the connectors on it.
12. 本製品は赤外線リフローでの実装を想定しています。N₂リフローで実装した場合、リフロー後、はんだ上がりを生じる恐れがあります。N₂リフローでの実装をお考えの場合、別途評価が必要になります。Please investigate the mounting condition (reflow soldering condition) on your own devices beforehand. The mounting conditions may change due to the soldering temperature, soldering paste, IR reflow machine, Nitrogen reflow machine, and the type of PCB. The different mounting conditions may have an influence on the product's performance.
13. 弊社評価では厚さ 0.12mm、開口率 100%のメタルマスクを使用しています。
Thickness 0.12mm, aperture ratio 100% stencil is used in this specification.
14. リフロー条件によっては端子めっき部にヨリ等が発生する場合がありますが、製品性能には影響ありません。
There is no influence in the product performance though the twist might be generated in the terminal plating part according to the reflow condition.
15. リフロー条件によっては樹脂部に変色が発生する場合がありますが、製品性能には影響ありません。
There is no influence in the product performance though discoloration might be generated in the resin according to the reflow condition.
16. リフロー後、はんだ付け部に変色が見られることがありますが、製品性能に影響はありません。
Although there might be some discoloration seen on the soldering tail after reflow, this will not influence the product's performance.
17. 本製品のハウジング材料は耐熱性ポリアミドを使用しており、ハウジングの吸水状態、或いは、はんだ付け条件によっては、リフローはんだ付け時にハウジング表面に「ふくれ」が発生する可能性があります。この「ふくれ」に関しましては、ポリアミド材の物性変化を伴うものではなく、製品機能を損なうものではありません。
The housing material of this product is made from a high heat resistant polyamide. The soldering condition and the water absorption properties of the housing material may cause blistering on the housing surface. Because this blister is not caused by property change, it does not damage the product's features.

THIS DOCUMENT CONTAINS INFORMATION THAT IS PROPRIETARY TO MOLEX ELECTRONIC TECHNOLOGIES, LLC AND SHOULD NOT BE USED WITHOUT WRITTEN PERMISSION

REVISION DESCRIPTION	REVISED	PICO-CLASP1.0 WIRE TO BOARD CONNECTOR SINGLE ROW INNER LOCK TIN PLATING 製品仕様書					
CHANGE NO.	639978						
REVISED BY	MIKEDA01	DATE	2020/06/23	DOC TYPE	DOC TYPE DESCRIPTION	DOC PART	SERIES
REV APPR BY	KOMURAKAMI	DATE	2020/06/26	PS	ENGINEERING SPECIFICATION WORD	001	501330
INITIAL RELEASE				CUSTOMER	DOCUMENT NUMBER	REVISION	SHEET
INITIAL DRWN	AISHIKAWA	DATE	2019/03/27	GENERAL	5013300000-PS	B	13 OF 19
INITIAL APPR	SAKIYAMA	DATE	2019/09/17				
TEMPLATE: 2090580003-PPS-A4 Rev A2 2020/04/05							

18. 実装性能（平坦度）は、実装基板の反りの影響を含まないものと致します。基板の反りはコネクタ両端部を基準とし、コネクタ中央部にて Max0.02mm としてください。
The mounting specification for coplanarity does not include the influence of warpage of the PCB. The warpage of the PCB should be a maximum of 0.02mm if measuring from one connector edge to the other.
19. 本製品の平坦度については、実装前での保証のみであり、実装中および実装後での平坦度については、保証の限りではありません。
Coplanarity is assured only before mounting.
There is no guarantee of coplanarity after mounting and in the reflow.
20. HS'G の樹脂の特性上、吸湿によりリフロー加熱時にブリストタが発生する可能性があります。防湿梱包開梱後の推奨保管条件を超えた場合、下記条件でのベーキングを推奨します。
ベーキング条件：恒温槽 50°C 10 時間放置
Because of property of HS'G resin, blister might be generated during reflow heating by hygroscopicity. When the storage condition after opening the humidity prevention package of product is over recommended storage condition, baking is recommended with below condition.
Baking condition : put in 50°C temperature chamber for 10 hours.

- 製品の仕様について Product Specification -

21. 本製品を結露・水濡れが発生する環境でのご使用の場合は、適切な防滴処置をお願い致します。結露・水濡れにより、回路間で絶縁不良を起こす可能性が御座います。
When this product is used at a place where exposure to water could be expected, please handle with appropriate care to avoid damage from water.
There is a possibility of causing insulated malfunction between the circuits.
22. コネクタの性能を損なう恐れがある為、コネクタの洗浄は、行わないでください。
Please do not conduct any washing process on the connectors because it may damage the product's function.
23. 本製品をご使用時に取り付けられた電線・プリント基板の共振や、機器の回転構造や可動部分の動作によりコネクタ嵌合部（接点部）が常に動いてしまう状態での御使用は避けてください。接触部の摺動磨耗等による接触不良の原因となります。従って、機器内で電線・プリント基板を固定し、共振を抑える等の処置をお願い致します。
Please do not use the connectors in a condition where the wire, PCB, or the contact area is experiencing a sympathetic vibration of wires and PCB, and constant movement of devices.
This may cause a defect in the contact due to the contact area being worn down. Therefore, please fix wires and PCB on the chassis, and reduces sympathetic vibration.
24. 本製品をご使用時には、1PIN 当りの定格以上の電流を複数の回路に分岐しての使用は避けてください。
When using this product, please ensure that the specification for rated current per circuit is followed. Do not allow the sum of the current used on several circuits to exceed the maximum allowable current.

THIS DOCUMENT CONTAINS INFORMATION THAT IS PROPRIETARY TO MOLEX ELECTRONIC TECHNOLOGIES, LLC AND SHOULD NOT BE USED WITHOUT WRITTEN PERMISSION

REVISION DESCRIPTION	REVISED	PICO-CLASP1.0 WIRE TO BOARD CONNECTOR SINGLE ROW INNER LOCK TIN PLATING 製品仕様書					
CHANGE NO.	639978						
REVISED BY	MIKEDA01	DATE	2020/06/23	DOC TYPE	DOC TYPE DESCRIPTION	DOC PART	SERIES
REV APPR BY	KOMURAKAMI	DATE	2020/06/26	PS	ENGINEERING SPECIFICATION WORD	001	501330
INITIAL RELEASE				CUSTOMER	DOCUMENT NUMBER	REVISION	SHEET
INITIAL DRWN	AISHIKAWA	DATE	2019/03/27	GENERAL	5013300000-PS	B	14 OF 19
INITIAL APPR	SAKIYAMA	DATE	2019/09/17				
TEMPLATE: 2090580003-PPS-A4 Rev A2 2020 / 04 / 05							

25. コネクタに外力が加わらないようにクリアランスをあげた筐体構造にしてください。
Please keep enough clearance between connectors and chassis of your application in order not to apply pressure on the connectors.
26. ハーネス加工品及びコネクタ嵌合後の電線の引き回しの際、引張りによる力が加わりますと、接点部、結線部（圧着部）やロック部（端子ロック部）が損傷を受け、接触不良の原因となります。
電線の引回し配線をされる場合、コネクタに無理な外力が加わらないように、電線に緩みを持たせ、余裕を持たせる処置をしてください。
The cable assembly should not have a constant stress or pulling force applied on it when it is in the mated condition. This phenomenon may damage the contact area or wiring area (crimping). Therefore, when designing the wire positioning, please ensure that there is enough length of wire to avoid stress on the connectors.
27. コネクタに適用できる電線は、原則として錫めっき付軟銅撚り線です。
その他の電線の使用については別途ご確認ください。
The applicable wire for this connector, in principle, is tin-plated copper stranded wire. Please consult us and evaluate it in advance when using other wires.
28. 梱包品の推奨保管条件を超えた場合は外観、はんだ付け性を確認の上ご使用ください。
Please use it after confirming externals and soldering when the storage condition of packing goods is over recommended storage condition.
29. 本製品のレセプタクルハウジング材料はポリアミドを使用しており、吸水状態によって挿抜力・挿入感が変わります。過度な吸水により、挿入時に嵌合相手と若干干渉する場合や、クリック感が弱くなる場合がありますが、製品性能、機能には問題ございません。
Because the receptacle housing material of this product is using polyamide, the water absorption status of the housing material might change insertion force, withdrawal force, or the feeling of insertion. Its excessive water absorption may cause to interfere with insertion a little bit or to weaken the click feeling of the lock when mating. However it does not damage the product's features and functions.
30. 本製品及び加工工程品（仕掛品）や加工品（ハーネス品）の梱包及び輸送・保管時において、コネクタ間での絡みや衝撃、積み重ね等による負荷が掛からないようにしてください。変形・破損等による性能不良の原因となります。
At packaging, transportation and storing, avoid applying loads to connectors by handling, interference of connectors or piling-up packages. It could cause functional defect such as connector deformation or breakage.

THIS DOCUMENT CONTAINS INFORMATION THAT IS PROPRIETARY TO MOLEX ELECTRONIC TECHNOLOGIES, LLC AND SHOULD NOT BE USED WITHOUT WRITTEN PERMISSION

REVISION DESCRIPTION	REVISED	PICO-CLASP1.0 WIRE TO BOARD CONNECTOR SINGLE ROW INNER LOCK TIN PLATING 製品仕様書					
CHANGE NO.	639978						
REVISED BY	MIKEDA01	DATE	2020/06/23	DOC TYPE	DOC TYPE DESCRIPTION	DOC PART	SERIES
REV APPR BY	KOMURAKAMI	DATE	2020/06/26	PS	ENGINEERING SPECIFICATION WORD	001	501330
INITIAL RELEASE				CUSTOMER	DOCUMENT NUMBER	REVISION	SHEET
INITIAL DRWN	AISHIKAWA	DATE	2019/03/27	GENERAL	5013300000-PS	B	15 OF 19
INITIAL APPR	SAKIYAMA	DATE	2019/09/17				
TEMPLATE: 2090580003-PPS-A4 Rev A2 2020 / 04 / 05							

- 製品操作について Operation -

- 31. コネクタの詳細な取り扱いにつきましては、別に定めるコネクタ取り扱い説明書：5013300000-AS PS 000 を参照してください。
Refer to the Application Specification (5013300000-AS PS 000) for details of connector handling instruction.
- 32. ポジティブロックの場合、コネクタの嵌合を取り外す際は、かならずロックを解除して行ってください。
When connectors are unmated, positive locks shall be released. (applicable Positive Lock type)
- 33. 嵌合嵌合時にリセハウジングの矢印で示す部位を押し嵌合してください。
電線やハウジングのロック部を押した場合、これらが破損する恐れがありますのでお避けください。
Please push the part directed by FIG.1 at the time of mate.
It may damage, when electric wires or lock part of the receptacle housing are pushed.



図1
FIG.1

- 34. 嵌合は極力嵌合軸に沿って平行に行ってください。その際、リセハウジングとプラグの外壁同士を合わせる様に位置決めした後に押し込み、コネクタ同士が突き当たる（完全嵌合位置）まで真っ直ぐ押し込んでください。斜めの嵌合になる場合は 10°以下の角度でリセハウジングとプラグの外壁同士を軽く当て、位置決めした後に嵌合してください。尚、コネクタ同士を過度に傾けた状態で嵌合を行いますと、ハウジングが破壊する恐れがありますのでこのような嵌合はお避けください。
Please do the mating as much as possible to along to mating axis. At this time, positioning each side of external faces of receptacle housing and plug and push to mating until both connectors strikes each other (complete mating position). In the case of diagonal mating, touch with external faces with receptacle housing and plug under the angle of 10° lightly, and push to mating in order to avoid the connector break.

THIS DOCUMENT CONTAINS INFORMATION THAT IS PROPRIETARY TO MOLEX ELECTRONIC TECHNOLOGIES, LLC AND SHOULD NOT BE USED WITHOUT WRITTEN PERMISSION

REVISION DESCRIPTION		REVISED		PICO-CLASP1.0 WIRE TO BOARD CONNECTOR SINGLE ROW INNER LOCK TIN PLATING 製品仕様書			
CHANGE NO.		639978					
REVISED BY	MIKEDA01	DATE	2020/06/23	DOC TYPE	DOC TYPE DESCRIPTION	DOC PART	SERIES
REV APPR BY	KOMURAKAMI	DATE	2020/06/26	PS	ENGINEERING SPECIFICATION WORD	001	501330
INITIAL RELEASE				CUSTOMER	DOCUMENT NUMBER	REVISION	SHEET
INITIAL DRWN	AISHIKAWA	DATE	2019/03/27	GENERAL	5013300000-PS	B	16 OF 19
INITIAL APPR	SAKIYAMA	DATE	2019/09/17				

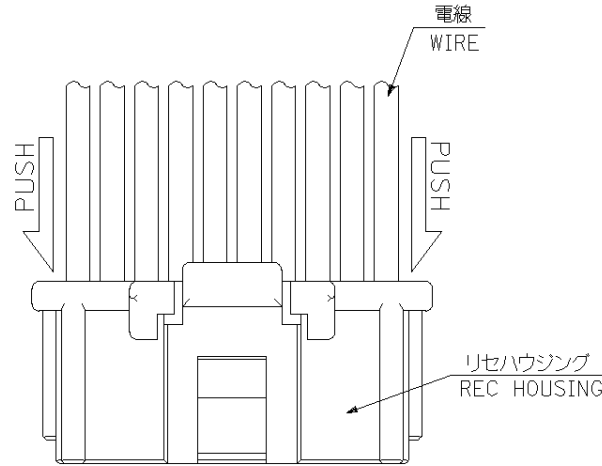
35. コネクタ嵌合状態で基板の持ち運び等コネクタに負荷が掛かる作業は行わないようにしてください。コネクタ破損等の原因となる場合が御座います。
Please do not do work that the load hangs in the connectors like the carrying of the substrate etc. with the connectors engages. There is a case where it causes the connectors damage etc.
36. 嵌合後、コネクタピッチ方向、スパン方向及び回転方向への負荷がかかるような動作またはセットはしないでください。コネクタ破壊やはんだクラックを引き起こします。
After mated the connectors, please do not allow the PCBs to apply pressure on the connectors in either the pitch direction, the span direction or rotational direction. It may cause damage to the connectors and may crack the soldering.
37. 活電状態の電気回路で、挿入、抜去ができることを前提に作られておりません。スパーク等による危険の発生、性能不良につながりますので、活電状態での挿入、抜去はしないでください。
This product is not designed for the mating and unmating of the connectors to be performed under the condition of an active electrical circuit. It may cause a spark and product defect if the connectors are mated and unmated in this way.
38. 電線の結束はコネクタから 35mm 以上のところで、電線に加わる力が均一になるようにしてください。ハーネス品で電線一本（又は特定の数本）に力が加わらない様にしてください。
Please tie the cable at least 35mm away from the edge of the connectors and try to ensure that the force is applied evenly on all of the wires.
39. 電線はまとめて軽くつかみ、ポジティブロックの場合はリセプタクルハウジングのロックに指を添え、指の平を用いて、ロック解除用バーを押してロックを完全に解除してから、ゆっくり、軸方向にまっすぐに引き抜いてください。また、斜めにこじりながら抜くことは避けてください。コネクタを破損させる恐れが御座います。
Please hold wires all together lightly. About positive lock type, after releasing lock completely by attaching fingers to the lock and pushing bar for releasing lock using flat part of finger, please withdraw receptacle housing slowly, axially and straightly. Please avoid withdrawing them with an angle and roughly. That might cause damage to connector.
40. ハウジングのロック部やランス部などの可動部、及び端子を故意に変形させないでください。製品性能が満足出来ない原因となります。
Do not deform the movable part as lock part and lance part of Plug, HS'G and terminals on purpose. It would lead to product failure.
41. コネクタのみで基板を支えることは避け、コネクタ以外での基板固定対策を行ってください。
Please do not use the connectors alone to provide mechanical support for the PCB.
Please ensure that there is a fixed structure on the phone chassis or other component support for the PCB.
42. 圧着端子リールの取り扱いについて、圧着端子リール梱包品 取扱説明書(AS-56000-001)を参照してください。
For crimp terminal reel handling, please refer to reel packaging for crimp terminal application specification (AS-56000-001).

THIS DOCUMENT CONTAINS INFORMATION THAT IS PROPRIETARY TO MOLEX ELECTRONIC TECHNOLOGIES, LLC AND SHOULD NOT BE USED WITHOUT WRITTEN PERMISSION

REVISION DESCRIPTION	REVISED	PICO-CLASP1.0 WIRE TO BOARD CONNECTOR SINGLE ROW INNER LOCK TIN PLATING 製品仕様書					
CHANGE NO.	639978						
REVISED BY	MIKEDA01	DATE	2020/06/23	DOC TYPE	DOC TYPE DESCRIPTION	DOC PART	SERIES
REV APPR BY	KOMURAKAMI	DATE	2020/06/26	PS	ENGINEERING SPECIFICATION WORD	001	501330
INITIAL RELEASE				CUSTOMER	DOCUMENT NUMBER	REVISION	SHEET
INITIAL DRWN	AISHIKAWA	DATE	2019/03/27	GENERAL	5013300000-PS	B	17 OF 19
INITIAL APPR	SAKIYAMA	DATE	2019/09/17				
TEMPLATE: 2090580003-PPS-A4 Rev A2 2020/04/05							

- リペアについて Repair -

43. 治具等を使用して圧着端子を抜いた場合には、ランスが変形し強度が低下し端子を再装着後の端子保持力が極端に低下します。そのため、圧着端子のリペアの際には新しいハウジングを必ず使用してください。

When extracting a crimp terminal from the housing using a jig, it may deform the housing lance and therefore reduce the terminal retention force enormously after re-inserting of the terminal. Therefore, please ensure to use a new housing after repairing the crimp terminals.

44. 実装後においてはんだゴテによるリペアを行なう際は、必ず仕様書掲載の条件以内で行なってください。条件を超えて実施した場合、端子の抜け、接点ギャップの変化、モールドの変形、溶融等が原因により破損の原因になります。

Please conduct it under the condition of the specifications when repairing by hand soldering iron after mounting. In the case of practicing beyond the condition, the backlash, the change in the contact gap, the deformation of the mold and the melting, etc. may cause damage.

45. はんだゴテによる手修正を行なう際、過度のはんだやフラックスを使用しないでください。はんだ上がりやフラックス上がりにより接触、機能不良に至る場合がございます。

When conducting manual repairs using a soldering iron, please do not use more solder and flux than needed. This may cause solder wicking and flux wicking issues, and it will eventually cause a contact defect and functional issues.

THIS DOCUMENT CONTAINS INFORMATION THAT IS PROPRIETARY TO MOLEX ELECTRONIC TECHNOLOGIES, LLC AND SHOULD NOT BE USED WITHOUT WRITTEN PERMISSION

REVISION DESCRIPTION	REVISED	PICO-CLASP1.0 WIRE TO BOARD CONNECTOR SINGLE ROW INNER LOCK TIN PLATING 製品仕様書					
CHANGE NO.	639978						
REVISED BY	MIKEDA01	DATE	2020/06/23	DOC TYPE	DOC TYPE DESCRIPTION	DOC PART	SERIES
REV APPR BY	KOMURAKAMI	DATE	2020/06/26	PS	ENGINEERING SPECIFICATION WORD	001	501330
INITIAL RELEASE				CUSTOMER	DOCUMENT NUMBER	REVISION	SHEET
INITIAL DRWN	AISHIKAWA	DATE	2019/03/27	GENERAL	5013300000-PS	B	18 OF 19
INITIAL APPR	SAKIYAMA	DATE	2019/09/17				

