

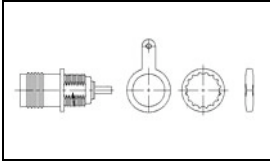

## 5-1814804-3 Product Details

[Share](#) [Print](#) [Email](#)



**5-1814804-3**

TE Internal Number: 5-1814804-3  
 **Active**

### TNC RF Connectors

 Always EU RoHS/ELV Compliant (Statement of Compliance)

#### Product Highlights:

- Connector - RF
- Bulkhead Jack
- Applies To Coaxial Cable
- Coaxial Cable Termination Type = Solder
- Body Style = Straight

[View all Features](#)

### Quick Links

- ▶ [Pricing & Availability](#)
- ▶ [Search for Tooling](#)
- ▶ [Product Feature Selector](#)
- ▶ [Contact Us About This Product](#)

[Add to My Part List](#)

[Request Sample](#)

[Find Similar Products](#)

[Buy Product](#)

### Documentation & Additional Information

#### Product Drawings:

- [TNC BULKHEAD SOCKET FRONT MOUNT 50 & 75 OHM \(PDF, English\)](#)

#### Catalog Pages/Data Sheets:

- None Available

#### Product Specifications:

- None Available

#### Application Specifications:

- None Available

#### Instruction Sheets:

- None Available

#### CAD Files:

- None Available

#### Related Products:

- [Tooling](#)

[List all Documents](#)

### Product Features (Please use the Product Drawing for all design activity)

#### Product Type Features:

- [Product Type](#) = Connector - RF
- Gender = Bulkhead Jack
- Weatherproof = No
- Dielectric Material = PTFE

#### Mechanical Attachment:

- [Panel Mount Retention](#) = With
- Panel Mount Retention Type = Lockwasher and Nut

#### Electrical Characteristics:

- [Connector Impedance \(Ω\)](#) = 50

#### Termination Features:

- [Coaxial Cable Termination Type](#) = Solder

#### Body Features:

- [Body Style](#) = Straight
- [Body Material](#) = Zinc
- [Body Plating](#) = Nickel

#### Contact Features:

- Center Contact Plating = Gold
- Center Contact Material = Phosphor Bronze

#### Configuration Features:

- [Solder Terminal](#) = With

#### Industry Standards:

- Government/Industry Qualification = No
- [RoHS/ELV Compliance](#) = RoHS compliant, ELV compliant
- [Lead Free Solder Processes](#) = Not relevant for lead free process
- RoHS/ELV Compliance History = Always was RoHS compliant

#### Conditions for Usage:

- [Applies To](#) = Coaxial Cable

#### Other:

- Brand = TE Connectivity

### Corporate Information

[About TE](#)  
[Investors](#)  
[News Room](#)  
[Supplier Portal](#)  
[Careers](#)  
[Terms & Conditions](#)  
[Privacy Policy](#)

### Quick Links

[Distributor Inventory](#)  
[Product Cross Reference](#)  
[Documents & Drawings](#)  
[Product Compliance Support Center](#)  
[Site Map](#)

### Customer Support

[Email or Chat With Us](#)  
[Find a Phone Number](#)  
[Knowledge Base](#)  
[Manage Your Account](#)

**Keep Me Informed**

THIS DRAWING IS UNPUBLISHED. RELEASED FOR PUBLICATION AUGUST, 2006.

© COPYRIGHT 2006 By - ALL RIGHTS RESERVED.

LOC	DIST	P	LTR	DESCRIPTION	DATE	DWN	APVD
E	B		B1	REVISED PER ECO-11-005033	01APR11	RK	HMR
			C	REVISED PER ECO-12-009395	17MAY12	TITAN	MARTIN

NOTES:

- 1 PACK IN ACCORDANCE WITH AMP SPEC 107-3275
- 2 100 TRAY PACK IN ACCORDANCE WITH AMP SPEC 107-3275
- 3 Au PLATING
- 4 Ni PLATING
- 5 FOR TECHNICAL DATA REFER TO YOUR LOCAL TE CONNECTIVITY SALES OFFICE
- 6 ALL DIMENSIONS ARE NOMINAL FOR REFERENCE ONLY UNLESS OTHERWISE STATED

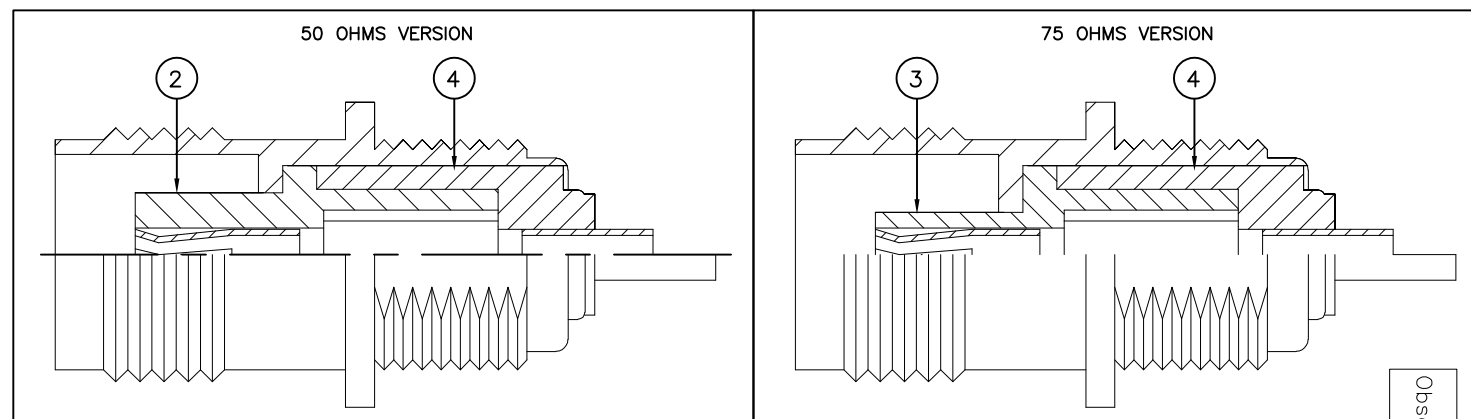
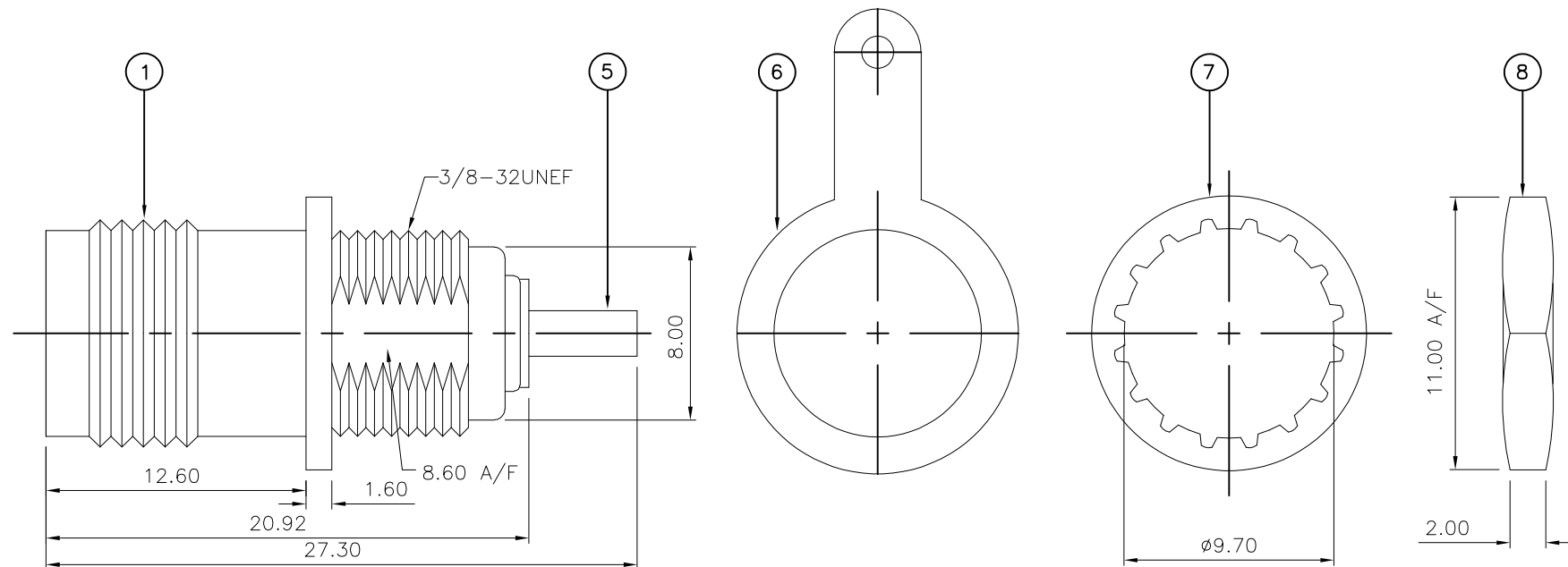

Obsolete

QTY	REV	REV	REV	MATERIAL	DESCRIPTION	ITEM
1	1	1	1	STEEL	HEXAGONAL NUT	8
1	1	1	1	STEEL	LOCKWASHER	7
1	1	1	1	BRASS	SOLDER TAG	6
1	1	1	1	PHOSPHOR BRONZE	CONTACT	5
1	1	1	1	PTFE	INSULATION	4
1	1	-	-	PTFE	INSULATION	3
-	-	1	1	PTFE	INSULATION	2
1	1	1	1	ZINC	BODY	1
5--3	5--2	5--1	5--0			
△	△	△	△			
QUANTITY PER ASSY				PARTS LIST		

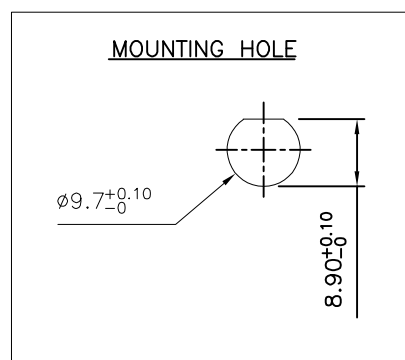

THIS DRAWING IS A CONTROLLED DOCUMENT.

DWN RITA ZUO 11 Mar 09  
CHK ANSON MA 11 Mar 09  
APVD BOB ZHAO 11 Mar 09

TE Connectivity  
TNC BULKHEAD SOCKET FRONT MOUNT  
50 & 75 OHM

108-112000

SIZE A3 CAGE CODE 00779 DRAWING NO C-1814804 RESTRICTED TO -

MATERIAL SEE TABLE FINISH - WEIGHT -

CUSTOMER DRAWING SCALE NTS SHEET 1 OF 1 REV C