



AP4351-2000

Action PAK® AP4351

Thermocouple-Input, Field Configurable Isolator

Provides Isolated, Linearized DC Output
in Proportion to Thermocouple Input



- Field Configurable Thermocouple Types
- Linearized Outputs
- Wide-Ranging Zero and Span Adjustability (50%
- Eliminates Ground Loops
- Thermocouple Burnout Detection
- ASIC Technology for Enhanced Reliability

Description

The AP4351 isolating thermocouple conditioner offers wide ranging input and output capability. The AP4351 can be field configured by the user to accept input from thermocouple types J, K, T, R, S, E, and B and to provide current or voltage output. The output is linearized to temperature according to the particular thermocouple type.

The AP4351 is a three-port industrial isolator — the output is optically isolated from the input up to 1500V, and both input and output are transformer isolated from the line power. Isolation allows the noise reduction benefits of grounded thermocouples to be realized without creating ground loop problems and it provides faster response. The AP4351 utilizes the latest in advanced analog/digital signal processing technology. In addition to its multiple microprocessors, it employs special ASIC circuitry for high accuracy and reliability.

The AP4351 is equipped with cold-junction compensation (CJC) circuitry to provide ice-point reference. Upscale, downscale or disabled thermocouple burnout detection is switch selectable.

Application

The Action Pak Model AP4351 is useful in any application requiring an isolated DC output from a thermocouple input. Typical applications include energy management and data acquisition of process temperatures. The output of the AP4351 can drive a digital meter for direct display or interface with a computer for monitoring and control applications.

Status LEDs

Model AP4351 is equipped with top-mounted LEDs for INPUT (green), TROUBLE (yellow) and CAL OK (yellow). At start-up, both the INPUT and the CAL OK LEDs light up momentarily for 1 second. Afterwards, these LEDs flash alternately for 10 seconds while start-up takes place.

Input LED

This input LED is a diagnostic tool. It remains continuously lit if the measured temperature is within the selected range of the thermocouple. However, if the measured temperature is outside the full range of the thermocouple (for example, for a type J - below minus 200°C or above 750°C), the LED will flash at a rate of 4 or

8Hz for under/over range, respectively. If the thermocouple is within the full temperature range, but outside the selected sub-range (for example, if a type J thermocouple is set for range 13 and the temperature is either below 375°C or above 500°C) the LED will flash at 0.5 or 1Hz respectively.

Cal OK LED

This LED is continuously on when the device is properly storing the factory calibration reference voltage.

Trouble LED

This LED is off during normal operation of the device. If this LED is on contact Action's Technical Services Group.

Options

- U** Urethane coating of internal circuitry for protection from corrosive atmospheres.
- C620** Factory calibration (specify input thermocouple type, temperature range and output).

Configuration

A major advantage of the AP4351 is its wide ranging capabilities and ease of configuration. The AP4351 enables 50% input zero and span adjustability within the selected sub-range.

For example, range #5 for an E-Type thermocouple in Table 6 specifies -18°C to 125°C. Since the span can be contracted by 50%, this enables an input span as narrow as 50% of 143°C, or 72°C. This span can then be positioned anywhere within the temperature range and can have a zero step-up as large as 50% of the full scale range (e.g. span can start as high as 53°C).

Unless otherwise specified, the factory pre-sets the Model AP4351 as follows:

| | |
|-----------|---------|
| Input: | J-type |
| Range: | 0-500°C |
| Output: | 4-20mA |
| Burn Out: | Upscale |

For other settings, remove the four base screws and polycarbonate case to access the configuration switches.

Refer to Tables 1 through 6 and Figures 1 through 3 for the proper switch locations and settings. Using the switch on the input board select thermocouple type, temperature range, and thermocouple burnout detection. Using the switch on the output board, select desired type of output. Replace the case prior to applying power to the unit.

Calibration

1. Connect the input to a calibrated thermocouple source and apply power. Wait 1-2 hours for thermal stability before monitoring the voltage/current output. Refer to PIN CONNECTIONS.

2. Set the calibrator to the desired minimum input and adjust the zero potentiometer for the desired minimum output.

3. Set the calibrator to the desired maximum input and adjust the span potentiometer for the desired maximum output.

4. Repeat steps 2 and 3, as necessary, for best accuracy.

Installation

Model AP4351 is pin-compatible with Action's AP4100, AP4130, AP4150, and AP4350, allowing for easy field upgrade.

Table 1: Thermocouple type switch settings (SW 1 on Input Board)

| TC Type | 8 | 9 | 10 |
|-----------------|-----|-----|-----|
| B | ON | ON | ON |
| E | ON | ON | OFF |
| J | ON | OFF | ON |
| K | ON | OFF | OFF |
| R | OFF | ON | ON |
| S | OFF | ON | OFF |
| T | OFF | OFF | ON |
| Not Used | OFF | OFF | OFF |

Table 3: Range switch settings used in conjunction with Table 6 (SW 1 on Input Board, SW1-3 is not used)

| Input Sub-Range | SW1-7 | SW1-6 | SW1-5 | SW1-4 |
|-----------------|-------|-------|-------|-------|
| 1 | OFF | ON | OFF | ON |
| 2 | OFF | ON | ON | ON |
| 3 | ON | OFF | ON | OFF |
| 4 | OFF | OFF | ON | ON |
| 5 | ON | ON | OFF | ON |
| 6 | ON | ON | ON | ON |
| 7 | ON | OFF | OFF | ON |
| 8 | OFF | OFF | OFF | ON |
| 9 | ON | ON | ON | OFF |
| 10 | OFF | ON | ON | OFF |
| 11 | OFF | ON | OFF | OFF |
| 12 | OFF | OFF | ON | OFF |
| 13 | ON | ON | OFF | OFF |
| 14 | ON | OFF | ON | ON |
| 15 | ON | OFF | OFF | OFF |
| 16 | OFF | OFF | OFF | OFF |

Table 4: Output switch settings (SW 1 on Output Board)

| Output | SW1-2 | SW1-1 |
|----------|-------|-------|
| 0 - 5V | ON | ON |
| 0 - 10V | OFF | ON |
| 0 - 1mA | ON | OFF |
| 4 - 20mA | OFF | OFF |

Table 2: Thermocouple burnout detection switch settings (SW 1 on Input Board)

| TC Burnout Detect | SW1-2 | SW1-1 |
|-------------------|-------|-------|
| Upscale | OFF | ON |
| Downscale | ON | OFF |
| Disable | OFF | OFF |
| Not Allowed | ON | ON |

Table 5: AP 4351 Accuracy

| TC Type | Temp. Range °C (°F) | Accuracy |
|----------|---------------------------------|-------------------|
| J | -200 to 750°C (-328 to 1382°F) | ±2.0 °C (±3.6°F) |
| K | -200 to -140°C (-328 to -220°F) | ±5.0 °C (±9.0°F) |
| | -140 to 1250°C (-220 to 2282°F) | ±2.0 °C (±3.6°F) |
| | 1250 to 1370°C (2282 to 2498°F) | ±4.0 °C (±7.2°F) |
| E | -150 to 1000°C (-238 to 1832°F) | ±2.5 °C (±4.5°F) |
| T | -150 to 400°C (-238 to 752°F) | ±3.0 °C (±5.4°F) |
| R | 50 to 1760°C (122 to 3200°F) | ±6.0 °C (±10.8°F) |
| S | 50 to 1760°C (122 to 3200°F) | ±6.0 °C (±10.8°F) |
| B | 500 to 1820°C (932 to 3308°F) | ±5.0 °C (±9.0°F) |

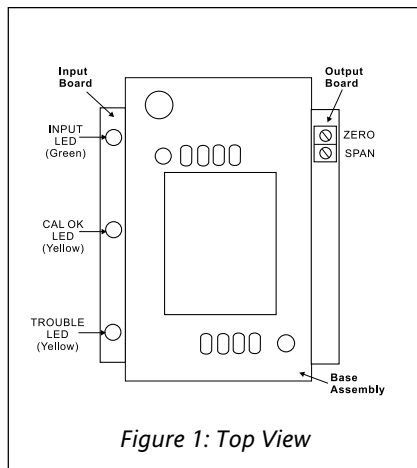

Figure 1: Top View

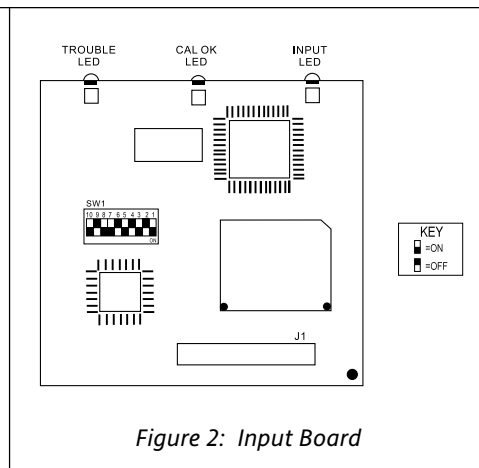

Figure 2: Input Board

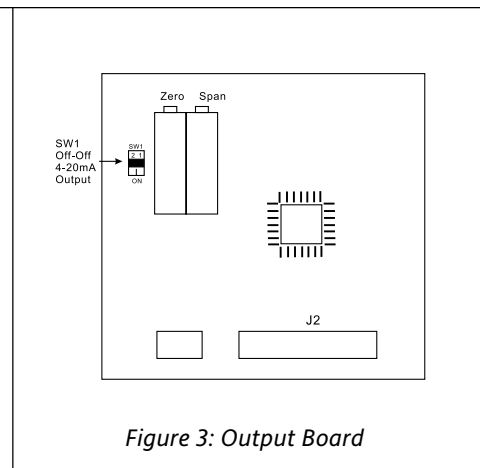

Figure 3: Output Board

Table 6: Thermocouple Range Settings

| TC Type | Range Number | Temperature Range | |
|---------|--------------|-------------------|-------------------|
| B | 6 | 500 to 1820° C | (932 to 3308° F) |
| | 7 | 1000 to 1820° C | (1832 to 3308° F) |
| | 8 | 500 to 1000° C | (932 to 1832° F) |
| | 11 | 1500 to 1820° C | (2732 to 3308° F) |
| | 12 | 750 to 1000° C | (1382 to 1832° F) |
| E | 2 | -18 to 1000° C | (0 to 1832° F) |
| | 3 | -18 to 500° C | (0 to 932° F) |
| | 4 | -18 to 250° C | (0 to 482° F) |
| | 5 | -18 to 125° C | (0 to 257° F) |
| | 8 | 500 to 1000° C | (932 to 1832° F) |
| | 9 | 250 to 500° C | (482 to 932° F) |
| | 10 | 125 to 250° C | (257 to 482° F) |
| | 12 | 750 to 1000° C | (1382 to 1832° F) |
| | 13 | 375 to 500° C | (707 to 932° F) |
| | 14 | -150 to 750° C | (-238 to 1382° F) |
| | 15 | -150 to 250° C | (-238 to 482° F) |
| J | 2 | -18 to 750° C | (0 to 1382° F) |
| | 3 | -18 to 500° C | (0 to 932° F) |
| | 4 | -18 to 250° C | (0 to 482° F) |
| | 5 | -18 to 125° C | (0 to 257° F) |
| | 8 | 500 to 750° C | (932 to 1382° F) |
| | 9 | 250 to 500° C | (482 to 932° F) |
| | 10 | 125 to 250° C | (257 to 482° F) |
| | 13 | 375 to 500° C | (707 to 932° F) |
| | 14 | -200 to 750° C | (-328 to 1382° F) |
| | 15 | -200 to 250° C | (-328 to 482° F) |
| | 16 | -200 to 0° C | (-328 to 32° F) |

| TC Type | Range Number | Temperature Range | |
|---------|--------------|-------------------|-------------------|
| K | 1 | -18 to 1370° C | (0 to 2498° F) |
| | 2 | -18 to 1000° C | (0 to 1832° F) |
| | 3 | -18 to 500° C | (0 to 932° F) |
| | 4 | -18 to 250° C | (0 to 482° F) |
| | 5 | -18 to 125° C | (0 to 257° F) |
| | 7 | 1000 to 1370° C | (1832 to 2498° F) |
| | 8 | 500 to 1000° C | (932 to 1832° F) |
| | 9 | 250 to 500° C | (482 to 932° F) |
| | 10 | 125 to 250° C | (257 to 482° F) |
| | 12 | 750 to 1000° C | (1382 to 1832° F) |
| | 13 | 375 to 500° C | (707 to 932° F) |
| | 14 | -200 to 750° C | (-328 to 1382° F) |
| | 15 | -200 to 250° C | (-328 to 482° F) |
| | 16 | -200 to 0° C | (-328 to 32° F) |

| TC Type | Range Number | Temperature Range | | |
|---------|--------------|-------------------|-------------------|---------------|
| R, S | 1 | 50 to 1760° C | (122 to 3200° F) | |
| | 2 | 50 to 1000° C | (122 to 1832° F) | |
| | 3 | 50 to 500° C | (122 to 932° F) | |
| | 4 | 50 to 250° C | (122 to 482° F) | |
| | 7 | 1000 to 1760° C | (1832 to 3200° F) | |
| | 8 | 500 to 1000° C | (932 to 1832° F) | |
| | 9 | 250 to 500° C | (482 to 932° F) | |
| | 10 | 125 to 250° C | (257 to 482° F) | |
| | 11 | 1500 to 1760° C | (2732 to 3200° F) | |
| | 12 | 750 to 1000° C | (1382 to 1832° F) | |
| | 13 | 375 to 500° C | (707 to 932° F) | |
| | T | 3 | -18 to 400° C | (0 to 752° F) |
| | | 4 | -18 to 250° C | (0 to 482° F) |
| 5 | | -18 to 125° C | (0 to 257° F) | |
| 9 | | 250 to 400° C | (482 to 752° F) | |
| 10 | | 125 to 250° C | (257 to 482° F) | |
| 13 | | 375 to 400° C | (707 to 752° F) | |
| 14 | | -150 to 400° C | (-238 to 752° F) | |
| 15 | | -150 to 250° C | (-238 to 482° F) | |
| 16 | -150 to 0° C | (-238 to 32° F) | | |

Mounting

All Action Paks feature plug-in installation. Model AP4351-2000 uses an 8-pin base and molded-sockets M008, or DIN-socket MD08.

Dimensions

Dimensions are in millimeters (inches)

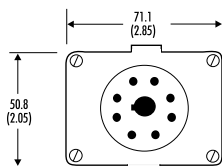
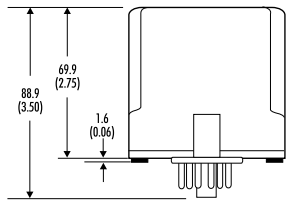

Mark III

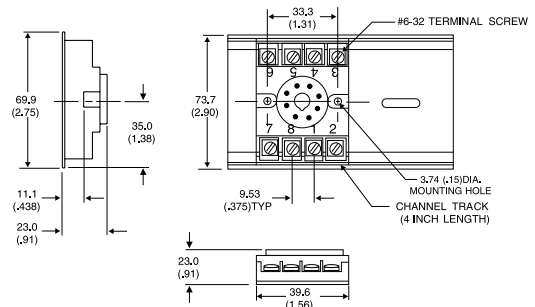

M008 (Track/Surface)

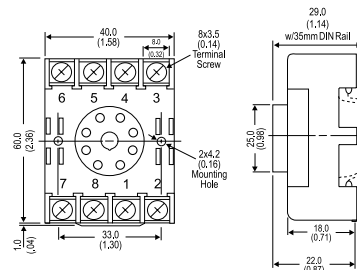

MD08 (DIN Rail)

Specifications

Inputs:

Ranges: field configurable, see Table 6
Impedance: >1M Ohms
Input Bias Current (burnout detection):
<1.5 microamp
Overvoltage: ±10V differential
Common Mode (Input to Ground):
1500VDC or peak AC, max
Zero and Span Range:
Zero Turn-Up:
0 to 50% of full scale range
Span Turn-Down:
100 to 50% of full scale range

Outputs:

Voltage Output: field-configurable
Ranges: 0-5V, 0-10V
Impedance: <10 Ohms
Drive: 10mA, max. (1K Ohms, min.)
Current Output: field-configurable
Ranges: 0-1mA, 4-20mA
Impedance: >100K Ohms
Compliance: 10V, max. (500 Ohms, max. @ 20mA)

Accuracy (Including Linearity, Hysteresis):

see Table 5

Response Time(10-90%):

500 mSec, typical

Stability:

±0.04%/°C of full scale range

Isolation:

1500VDC or peak AC between input,
output and power

ESD Susceptibility:

Meets IEC 801- 2, Level 2 (4KV)

Common Mode Rejection:

DC - 60Hz: 120dB

LED Indicators:

TROUBLE LED: Yellow - off during normal
device operation

INPUT LED: Green - continuously on if
input is within selected range, flashes
otherwise

CAL OK LED: Yellow - continuously on in
normal device operation

Thermocouple Burnout Detect:

Field-configurable Up or Downscale, or
disabled

Humidity (Non-Condensing):

Operating: 25 to 95% (@ 45°C)

Soak: 90% for 24 Hrs. (@65°C)

Temperature Range:

Operating: 0 to 60°C (32 to 140°F)

Storage: -15 to 75°C (5 to 167°F)

Power:

Consumption: 3W typical, 5W max

Standard: 120VAC ±10%, 50 - 60Hz

Optional: 240VAC

Weight:

0.62lbs

Approvals:

UL recognized per standard UL508.

(FileNo. E99775).

Ordering Information

Specify:

1. Model: **AP4351-2000**
2. Option: C620 factory calibration (specify input thermocouple type, temperature range and output).
3. Option: U, see text
4. Line Power, see specifications (All power supplies are transformer-isolated from the internal circuitry)

Accessories:

M801-0000 Retaining Spring
M008-A 8 pin Track Mount Socket
M004-0000 4 ft Long Channel Track
MD08-0000 8 pin DIN Mount Socket

Pin Connections

- 1 Power (Hot)
- 2 No Connection
- 3 Power (Neu)
- 4 Do not use
- 5 Input (+)
- 6 Input (-)
- 7 Output (+)
- 8 Output (-)



Eurotherm, Inc

741-F Miller Drive
Leesburg, VA 20175-8993
703-443-0000

info@eurotherm.com or www.eurotherm.com/actionio



Factory Assistance

For additional information on calibration, operation and installation contact our Technical Services Group:

703-669-1318

actionsupport@eurotherm.com

721-0510-00-L 02/09 Copyright© Eurotherm, Inc 2009