



**HIGH-TEMPERATURE (200°C)  
HIGH-PERFORMANCE  
TO-5 RELAY  
DPDT**



SERIES	RELAY TYPE
412H	DPDT High-Temperature relay
422H	DPDT Magnetic-Latching, High-Temperature relay
432H	DPDT Sensitive, High-Temperature relay

**DESCRIPTION**

The TO-5 relay, originally conceived and developed by Teledyne, has become one of the industry standards for low-level switching from dry circuit to 1 ampere. Designed for high-density PC board mounting, these TO-5 relays are some of the most versatile ultraminiature relays available because of their small size and low coil power dissipation.

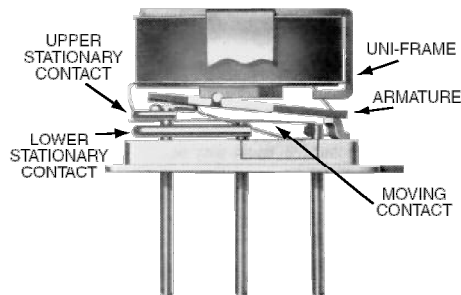
The H Series high-temperature TO-5 relays are designed for reliable operation in elevated ambient temperatures up to 200°C. Special material selection and processing provide assurance of freedom from contact contamination and mechanical malfunctioning that might otherwise be caused by ultra high ambient temperature conditions.

Typical applications:

- Oil exploration (down hole) instrumentation
- High temperature industrial and process control instrumentation

By virtue of its inherently low intercontact capacitance and contact circuit losses, the H Series relays have proven to be excellent ultraminiature RF switches for applications with frequency ranges well into the UHF spectrum.

**INTERNAL CONSTRUCTION**



412H 432H	ENVIRONMENTAL AND PHYSICAL SPECIFICATIONS	
Temperature	-65°C to +200°C	
Vibration (General Note 1)	30 g's to 3000Hz	
Shock (General Note 1)	75 g's 6msec, half-sine	
Acceleration	50 g's	
Enclosure	Hermetically Sealed	
Weight	412H	0.09 oz. (2.55g) max.
	432H	0.15 oz. (4.25g) max.

422H	ENVIRONMENTAL AND PHYSICAL SPECIFICATIONS	
Temperature	-65°C to +200°C	
Vibration (General Note 1)	30 g's to 3000Hz	
Shock (General Note 1)	100 g's 6msec, half-sine	
Acceleration	50 g's	
Enclosure	Hermetically Sealed	
Weight	0.10 oz. (2.84g) max.	

**SERIES 412H / 422H / 432H  
 GENERAL ELECTRICAL SPECIFICATIONS (@25°C)**

<b>Contact Arrangement</b>		2 Form C (DPDT)
<b>Rated Duty</b>		Continuous
<b>Contact Resistance</b>	<b>412H 432H</b>	0.125 Ω max. before life; 0.225 Ω max. after life @ 1A/28Vdc
	<b>422H</b>	0.15 Ω max. before life; 0.25 Ω max. after life @ 1A/28Vdc
<b>Contact Load Rating (DC)</b>		Resistive: 1 A / 28 Vdc Inductive: 200 mA / 28 Vdc (320mH) Lamp: 100 mA / 28 Vdc (320mH) Low level: 10 to 50 μA @ 10 to 50 mV
<b>Contact Load Rating (AC)</b>		Resistive: 250 mA / 115Vac, 60 and 400 Hz (Case not grounded) 100 mA / 115 Vac, 60 and 400 Hz (Case grounded)
<b>Contact Life Ratings</b>		10,000,000 cycles (typical) at low level 1,000,000 cycles (typical) at 0.5 A / 28 Vdc resistive 100,000 cycles min. at all other loads specified above
<b>Contact Overload Rating</b>		2 A / 28 Vdc Resistive (100 cycles min.)
<b>Coil Operating Power</b>	<b>412H</b>	450 mW typical at nominal rated voltage
	<b>422H</b>	290 mW typical at nominal rated voltage
	<b>432H</b>	200 mW typical at nominal rated voltage
<b>Operate Time</b>	<b>412H</b>	2.0 ms max.
	<b>422H</b>	1.5 ms max.
	<b>432H</b>	4.0 ms max.
<b>Contact Carry Rating</b>		Contact Factory
<b>Release Time</b>		2.0 ms max.
<b>Contact Bounce</b>		1.5 ms
<b>Min. Operate Pulse (422H)</b>		4.5 ms width at nominal rated voltage
<b>Intercontact Capacitance</b>		0.4 pf typical
<b>Insulation Resistance</b>		1,000 MΩ min. between mutually isolated terminals
<b>Dielectric Strength</b>		Atmospheric: 500 Vrms (60 Hz)      70,000 ft: 125 Vrms (60 Hz)

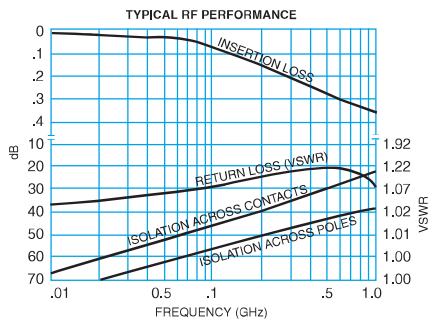
**SERIES 412H / 422H / 432H  
DETAILED ELECTRICAL SPECIFICATIONS (@25°C)**

BASE PART NUMBERS (412H)		412H-5	412H-12	412H-26
Coil Voltage	Nom.	5.0	12.0	26.5
	Max.	5.8	16.0	32.0
Drop-Out Voltage (Vdc)	Min.	0.14	0.41	0.89
	Max.	2.4	6.8	13.5
Coil Resistance (Ohms $\pm 10\%$ )		50	390	1560
Pick-up Voltage (Vdc, Max.) Pulse Operation		4.7	11.9	24.0

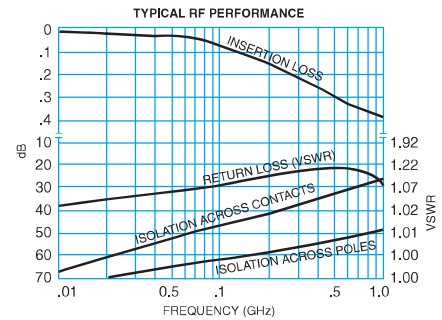
BASE PART NUMBERS (422H)		422H-5	422H-12	422H-26
Coil Voltage	Nom.	5.0	12.0	26.5
	Max.	5.8	16.0	32.0
Set & Reset Voltage (Vdc, Max.)		4.7	11.9	24.0
Coil Resistance (Ohms $\pm 10\%$ )		50	390	1560

BASE PART NUMBERS (432H)		432H-5	432H-12	432H-26
Coil Voltage	Nom.	5.0	12.0	26.5
	Max.	5.8	16.0	32.0
Drop-Out Voltage (Vdc)	Min.	0.14	0.41	0.89
	Max.	2.4	6.8	13.5
Coil Resistance (Ohms $\pm 10\%$ )		100	850	3300
Pick-up Voltage (Vdc, Max.) Pulse Operation		4.7	11.9	24.0

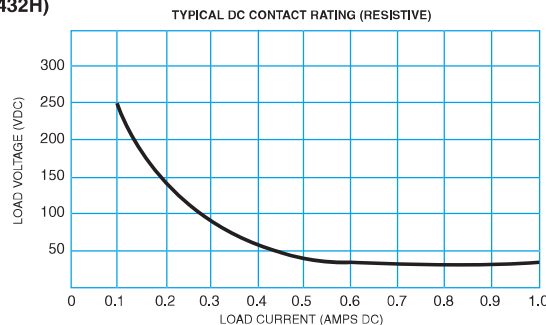
**PERFORMANCE CURVES  
(NOTE 2)**



**FIGURE 1 (412H AND 432H)**

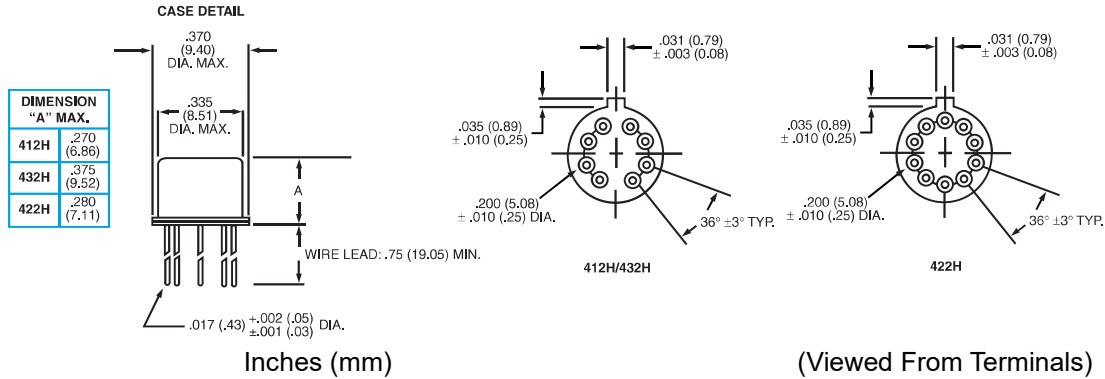


**FIGURE 2 (422H)**

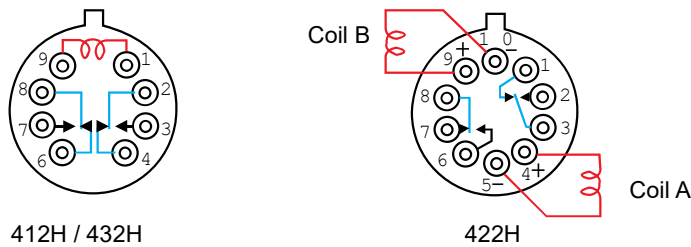


**FIGURE 3**

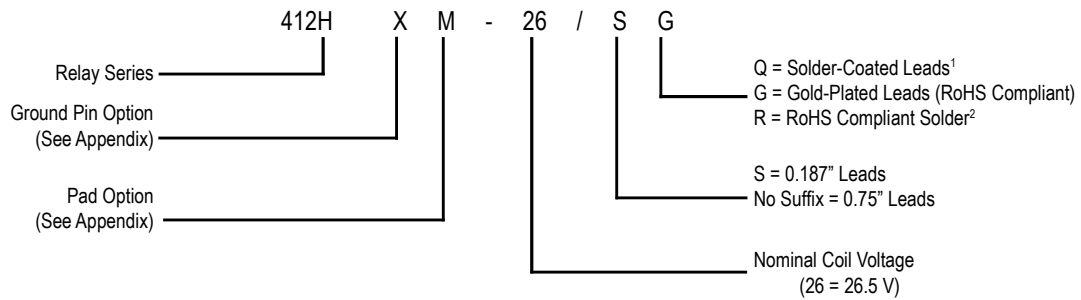
**SERIES 412H / 422H / 432H  
OUTLINE DIMENSIONS**



**SCHEMATIC DIAGRAMS**



**High Performance Relays**

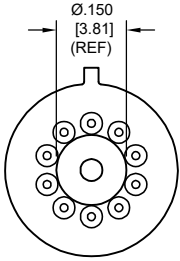
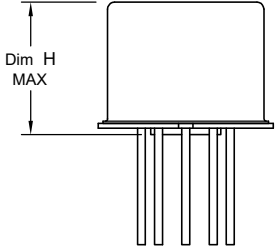
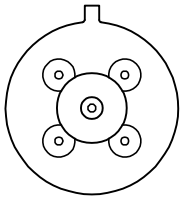
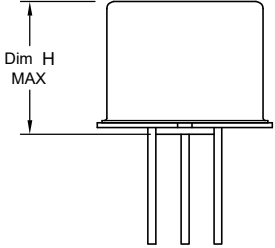
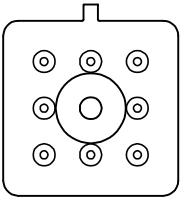
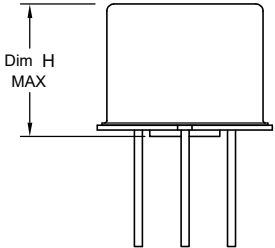
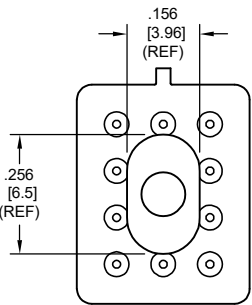
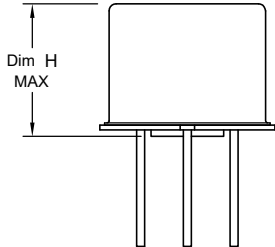


General Note: Parts ordered without suffix may be supplied with Solder-Coated or Gold-Plated leads.  
 1 Parts ordered with Solder-Coated leads will have (Sn60/Pb40)  
 2 Parts ordered with RoHS Solder-Coated leads will have (Sn99.3/Cu0.7)

**NOTES:**

- Relay contacts will exhibit no chatter in excess of 10  $\mu$ sec or transfer in excess of 1  $\mu$ sec.
- "Typical" characteristics are based on available data and are best estimates. No on-going verification tests are performed.
- Characteristics are subject to change after life.
- Contact load ratings and contact life ratings are based on similarity testing at 125°C. No 200°C testing is performed.

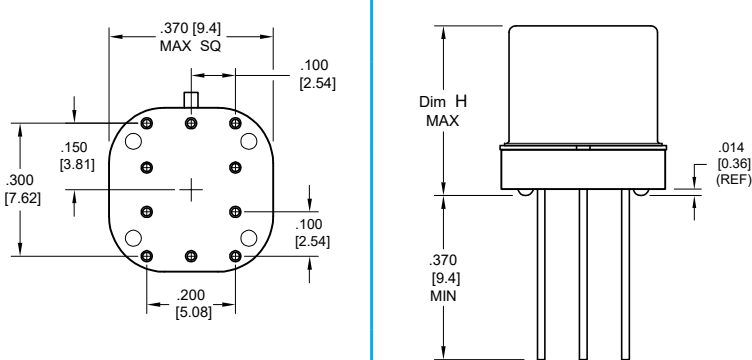
## APPENDIX A : Spacer Pads

Pad designation and bottom view dimensions	Height	For use with the following:	Dim. H Max.
 <p style="text-align: center;">“M4” Spacer Pad for TO-5</p>		ER412	.295 (7.49)
		712, RF300, RF, RF700, RF703	.300 (7.62)
		ER422, 722	.305 (7.75)
		ER432	.400 (10.16)
		732, RF303	.410 (10.41)
		RF312	.350 (8.89)
 <p style="text-align: center;">“M4”Spacer Pad for TO-5</p>		ER411	.295 (7.49)
		RF311	.300 (7.62)
		RF331	.410 (10.41)
 <p style="text-align: center;">“M4” Spacer Pad for Centigrid®</p>		172	.305 (7.75)
		ER114, J114	.300 (7.62)
		ER134, J134	.400 (10.16)
		RF100	.315 (8.00)
		RF103	.420 (10.67)
 <p style="text-align: center;">“M9”Spacer Pad for Centigrid®</p>		122C, A152	.320 (8.13)
		ER116C, J116C	.300 (7.62)
		ER136C, J136C	.400 (10.16)
		RF180	.325 (8.25)
		A150	.305 (7.75)

**Notes:**

1. Spacer pad material: Polyester film.
2. To specify an “M4” or “M9” spacer pad, refer to the mounting variants portion of the part numbering example in the applicable datasheet.
3. Dimensions are in inches (mm).
4. Unless otherwise specified, tolerance is  $\pm .010$ " (.25 mm).
5. Add 10 m $\Omega$  to the contact resistance shown in the datasheet.
6. Add 0.01 oz. (0.25 g) to the weight of the relay assembly shown in the datasheet.

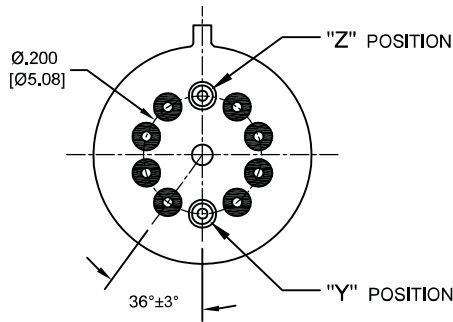
## APPENDIX A : Spreader Pads

Pad designation and bottom view dimensions	Height	For use with the following:	Dim. H Max.
 <p style="text-align: center;">"M" Spreader Pad <u>5/</u> <u>6/</u></p>		ER411T, ER412, J412	.388 (9.86)
		712	.393 (9.99)
		ER432, J432	.493 (12.52)
		732	.503 (12.78)
		J421, J422, ER422, 722	.398 (10.11)

**Notes:**

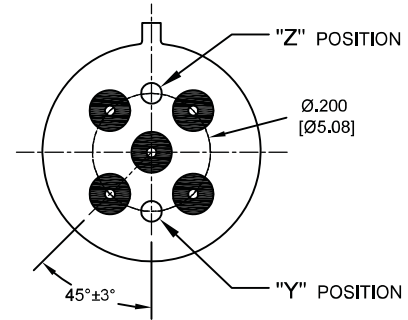
1. Spreader pad material: Diallyl Phthalate.
2. To specify an "M", "M2" or "M3" spreader pad, refer to the mounting variants portion of the part number example in the applicable datasheet.
3. Dimensions are in inches (mm).
4. Unless otherwise specified, tolerance is  $\pm .010$ " (0.25 mm).
- 5/. Add 25 m $\Omega$  to the contact resistance shown in the datasheet.
- 6/. Add .01 oz. (0.25 g) to the weight of the relay assembly shown in the datasheet.
- 7/. Add 50 m $\Omega$  to the contact resistance shown in the datasheet.
- 8/. Add 0.025 oz (0.71 g) to the weight of the relay assembly shown in the datasheet.
- 9/. M3 pad to be used only when the relay has a center pin (e.g. ER411M3-12A, 722XM3-26.)

# APPENDIX A : Ground Pin Positions



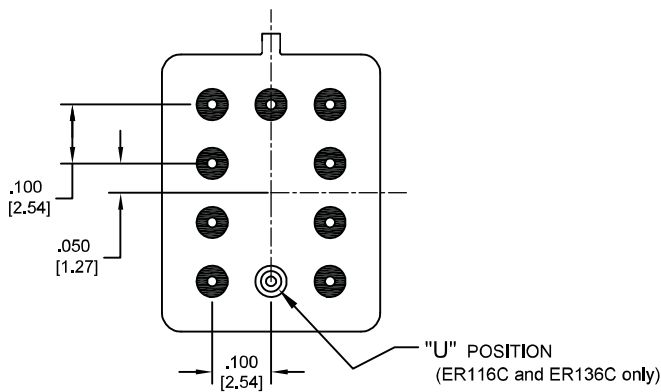
### TO-5 Relays:

ER412, ER412T, ER422, ER432, ER432T, 712, 712TN, 400H, 400K, 400V, RF300, RF303, RF341, RF312, RF332, RF310, RF313, RF320, RF323, SI800, SI803, RF700, RF703



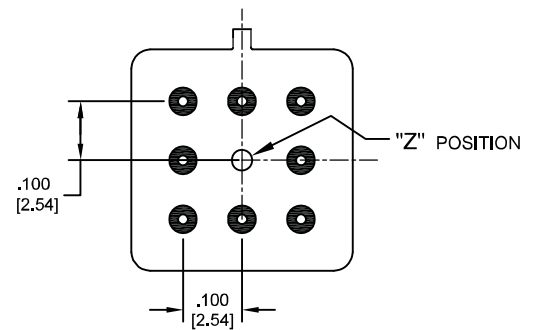
### TO-5 Relays:

ER411, RF311, RF331



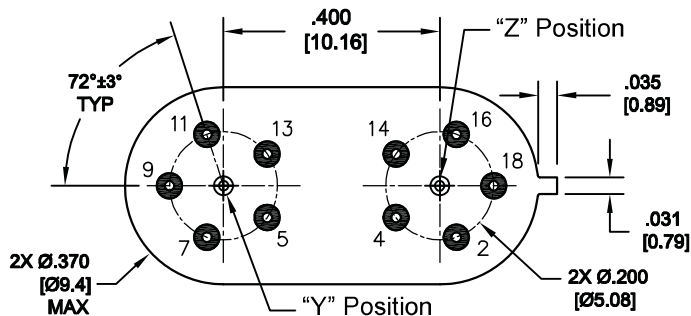
### Centigrid® Relays:

RF180, ER116C, 122C, ER136C



### Centigrid® Relays:

RF100, RF103, ER114, ER134, 172



### Loopback Relays:

LB363

### NOTES

- Indicates ground pin position
- Indicates glass insulated lead position
- ⊙ Indicates ground pin or lead position depending on relay type

1. Terminal views shown
2. Dimensions are in inches (mm)
3. Tolerances:  $\pm .010$  ( $\pm .25$ ) unless otherwise specified
4. Ground pin positions are within  $.015$  ( $0.38$ ) dia. of true position
5. Ground pin head dia.,  $0.035$  ( $0.89$ ) ref: height  $0.010$  ( $0.25$ ) ref.
6. Lead dia.  $0.017$  ( $0.43$ ) nom.