

Description

Single pole high performance thermal circuit breaker, with push-to-reset tease free, trip-free snap action mechanism (R-type TO CBE to EN 60934). Designed for threadneck panel mounting and for applications with a high fault current switching requirement.

Approved to CBE standard EN 60934 (IEC 60934).

Typical applications

Motors, transformers, solenoids, battery chargers, power supplies, appliances, machinery, extra low voltage systems.

Ordering information

Type No.	4130	single pole thermal circuit breaker
Mounting	G2	M12x1, knurled nut (bulk shipped with 5 pcs plus)
	G4	M12x1, hex nut and knurled nut (bulk shipped with 5 pcs plus)
Number of poles	1	single pole, thermally protected
Actuator configuration	1	black push button
Terminal design	K4	terminal M6x8 screw and washer bulk shipped
Characteristic curve	M1	medium delay
Current ratings	20... 80 A	
4130 - G2 1 1 - K4 M1 - 20 A ordering example		

Please be informed that we have minimum ordering quantities to be observed.

Preferred types

Preferred types	Standard current ratings (A)									
	20	25	30	35	40	45	50	60	70	80
4130-G211-K4M1-	x	x	x	x	x	x	x	x	x	x
4130-G411-K4M1-	x	x	x	x	x	x	x	x	x	x

Standard current ratings and typical internal resistance values

Current rating (A)	Internal resistance (Ω)	Current rating (A)	Internal resistance (Ω)
20	< 0.02	40	< 0.01
25	< 0.02	50	< 0.01
30	< 0.02	60	< 0.01
35	< 0.02	70	< 0.01
35	< 0,02	80	< 0,01



Technical data

For further details please see: http://www.e-t-a.de/ti_e

Voltage rating	AC 240 V; DC 50 V		
Current rating range	20...80 A		
Typical life	AC 240 V: 20...70 A	100 operations at 2 x I _N , inductive 500 operations at 2 x I _N , resistive	
	DC 50 V: 20...80 A	500 operations at 2 x I _N , inductive	
Ambient temperature	-30...+60 °C (-22...+140 °F)		
Insulation co-ordination (IEC 60664)	rated impulse withstand voltage 2.5 kV (reinforced insulation in the mounting area)	pollution degree 2	
Dielectric strength operating area	test voltage AC 3,000 V		
Insulation resistance	> 100 MΩ (DC 500 V)		
Interrupting capacity I _{cn}	800 A		
Interrupting capacity (UL 1077)	I _N 20...80 A	U _N AC 240 V	1,000 A
	20...60 A	AC 120 V	3,500 A
	80 A	AC 120 V	2,000 A
	20...50 A	DC 50 V	3,500 A
	60...80 A	DC 50 V	2,000 A
Degree of protection (IEC 60529/DIN 40050)	operating area IP40 terminal area IP00		
Vibration	8 g (57-500 Hz) ± 0.61 mm (10-57 Hz) to IEC 60068-2-6, test Fc 10 frequency cycles/axis		
Shock	25 g (11 ms) to IEC 60068-2-7, test Ea		
Corrosion	96 hours at 5 % salt mist, to IEC 60068-2-11, test Ka		
Humidity	240 hours at 95 % RH to IEC 60068-2-78, test Cab		
Mass	approx. 55 g		

Approvals

Authority	Standard	Rated voltage	Current ratings
VDE	IEC/EN 60934	AC 240 V DC 50 V	20 A...70 A 20 A...80 A
UL	UL 1077	AC 240 V DC 50 V	20 A...80 A 20 A...80 A
CSA	C22.2 No 235	AC 240 V DC 50 V	20 A...80 A 20 A...80 A

Dimensions

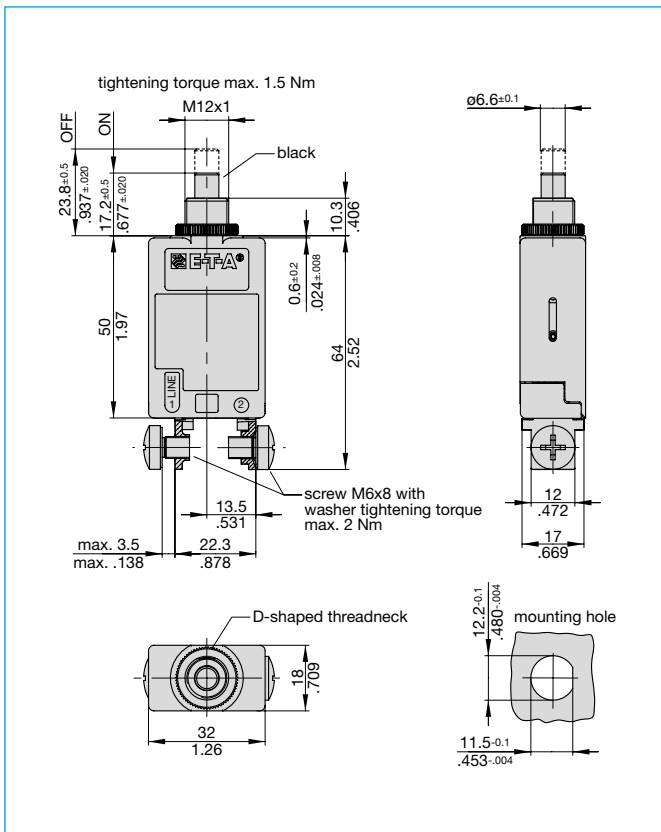

Typical time/current characteristics

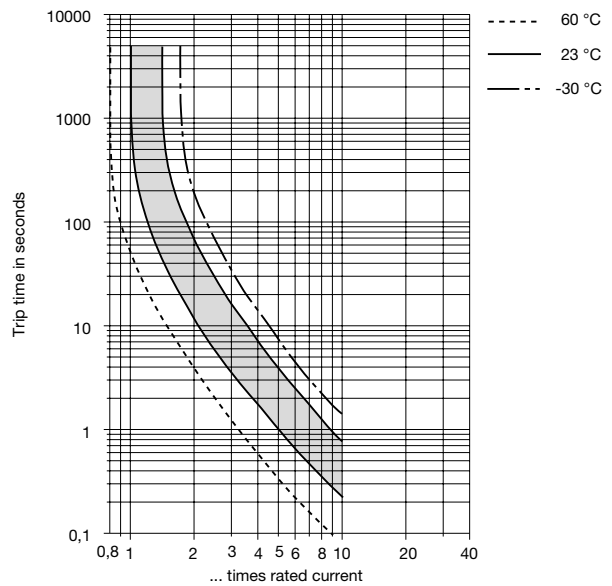

The time/current characteristic curve depends on the ambient temperature prevailing. In order to eliminate nuisance tripping, please multiply the circuit breaker current ratings by the derating factor shown below. See also section Technical information.

Ambient temp. °F	-22	-4	+14	+32	+73.4	+104	+122	+140
°C	-30	-20	-10	0	+23	+40	+50	+60
Derating factor	0.68	0.76	0.84	0.92	1	1.08	1.16	1.24

Installation drawing

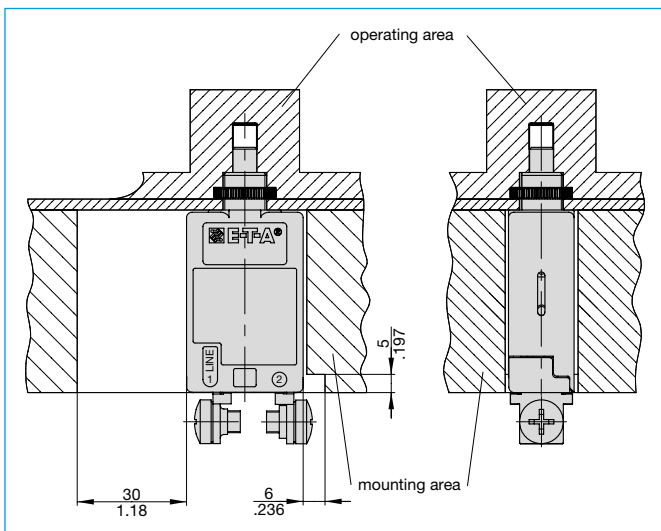

Internal connection diagram

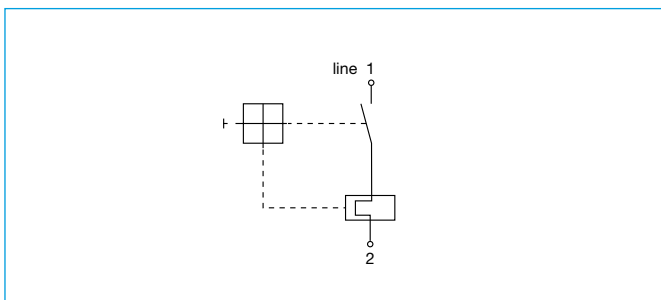

Accessories

- Hex nut with splash cover, black X 200 801 03 with O ring (IP66 /IP67)
- Hex nut with splash cover, transparent X 200 801 08 with O ring (IP66/IP67)
- Water splash cover, transparent with knurled nut and O ring (IP64) X 210 663 01

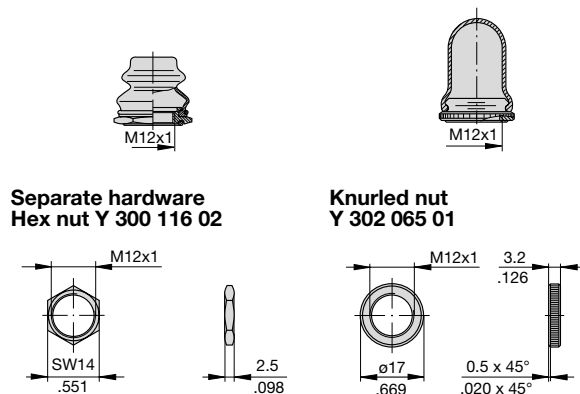

This is a metric design and millimeter dimensions take precedence ($\frac{\text{mm}}{\text{inch}}$)

All dimensions without tolerances are for reference only. In the interest of improved design, performance and cost effectiveness the right to make changes in these specifications without notice is reserved. Product markings may not be exactly as the ordering codes. Errors and omissions excepted.