

Product Data Sheet 4114 NXU

**ebmpapst**

The engineer's choice



4114 NXU

INDEX

**1 General ..... 3**

**2 Mechanics ..... 3**

    2.1 General ..... 3

    2.2 Connections ..... 3

**3 Operating Data ..... 4**

    3.1 Electrical Operating Data ..... 4

    3.2 Electrical Features ..... 4

    3.3 Aerodynamics ..... 6

    3.4 Sound Data ..... 8

**4 Environment ..... 8**

    4.1 General ..... 8

    4.2 Climatic Requirements ..... 8

**5 Safety ..... 10**

    5.1 Electrical Safety ..... 10

    5.2 Approval Tests ..... 10

**6 Reliability ..... 10**

    6.1 General ..... 10

**1 General**

Fan type	Fan	
Rotating direction looking at rotor	Clockwise	
Airflow direction	Air intake over struts	
Bearing system	Ball bearing	
Mounting position - shaft	Any	

**2 Mechanics**

**2.1 General**

Width	119,0 mm	
Height	119,0 mm	
Depth	38,0 mm	
Mass	0,405 kg	
Housing material	Metal	
Impeller material	Plastic	
Max. torque when mounted across both mounting flanges	Wire outlet corner: 170 Ncm Remaining corners: 300 Ncm	
Screw size	ISO 4762 - M3 degreased, without an additional brace and without washer	

**2.2 Connections**

Electrical connection	Wires	
Lead wire length	L = 310 mm	
Tolerance	+/- 10,0 mm	
Wire size (AWG)	22	
Insulation diameter	1,70 mm	

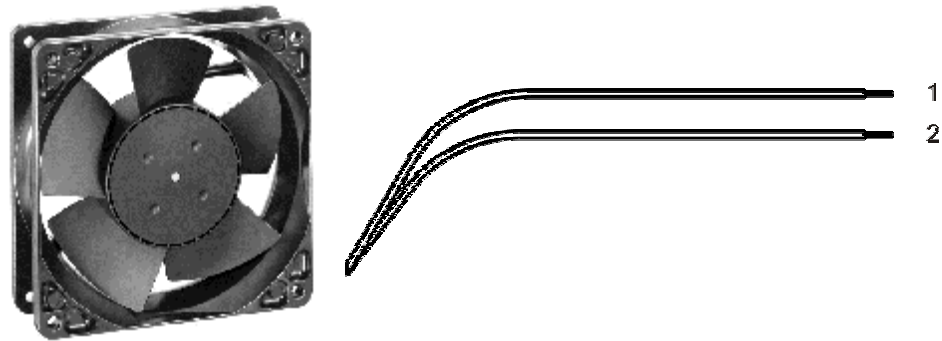

Wire	Color	Operation
1	red	+ UB
2	blue	- GND

### 3 Operating Data

#### 3.1 Electrical Operating Data

Measurement conditions: Normal air density = 1,2 kg/m<sup>3</sup>; Temperature 23°C +/- 3°C; Motor axis horizontal; warm-up time before measuring 5 minutes (unless otherwise specified). In the intake and outlet area should not be any solid obstruction within 0,5 m.

$\Delta p = 0$ : corresp. to free air flow (see chapter aerodynamics)  
 I: corresp. to arithm. mean current value

Features	Condition	Symbol	Values		
Voltage range		U	12 V		29 V
Nominal voltage		$U_N$		24 V	
Power consumption	$\Delta p = 0$	P	1,3 W	5 W	8,7 W
Tolerance	0010		+/- 17,5 %	+/- 12,5 %	+/- 15 %
Current consumption	$\Delta p = 0$	I	108 mA	208 mA	300 mA
Tolerance	0010		+/- 17,5 %	+/- 12,5 %	+/- 15 %
Speed	$\Delta p = 0$	n	1.680 1/min	3.200 1/min	3.750 1/min
Tolerance	0010		+/- 12,5 %	+/- 7,5 %	+/- 10 %
Starting current consumption				970 mA	

#### 3.2 Electrical Features

Electronic function	None	
Reversed polarity protection	Rectifying diode	
Max. residual current at $U_N$	$I_F \leq 10$ mA	
Locked rotor protection	Auto restart	
Locked rotor current at $U_N$	$I_{block}$ approx. 970 mA	
Clock signal at locked rotor	$t_3 / t_4$ typical: 0,6 s / 10 s	

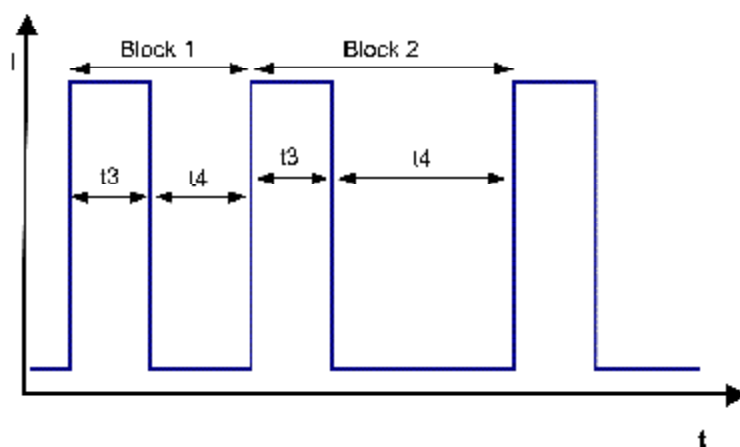

Block1: special locked rotor protection: 5 cycles  $t_3 / t_4 = 0,6 \text{ s} / 1 \text{ s}$  Block2: locked rotor protection  $t_3 / t_4 = 0,6 \text{ s} / 10 \text{ s}$

### 3.3 Aerodynamics

Measurement conditions: Measured with a double chamber intake rig acc. to DIN EN ISO 5801.  
 Normal air density = 1,2 kg/m<sup>3</sup>; Temperature 23°C +/- 3°C;  
 In the intake and outlet area should not be any solid obstruction within 0,5 m. Motor shaft horizontal.  
 The information is only valid under the specified test conditions and may be changed by the installation conditions. If there are deviations from the standard test conditions, the characteristic values must be checked under the installed conditions.

a.) Operation condition:

3.200 1/min at free air flow		
Max. free-air flow ( $\Delta p = 0 / \dot{V} = \text{max.}$ )	168,0 m <sup>3</sup> /h	
Max. static pressure ( $\Delta p = \text{max.} / \dot{V} = 0$ )	100 Pa	

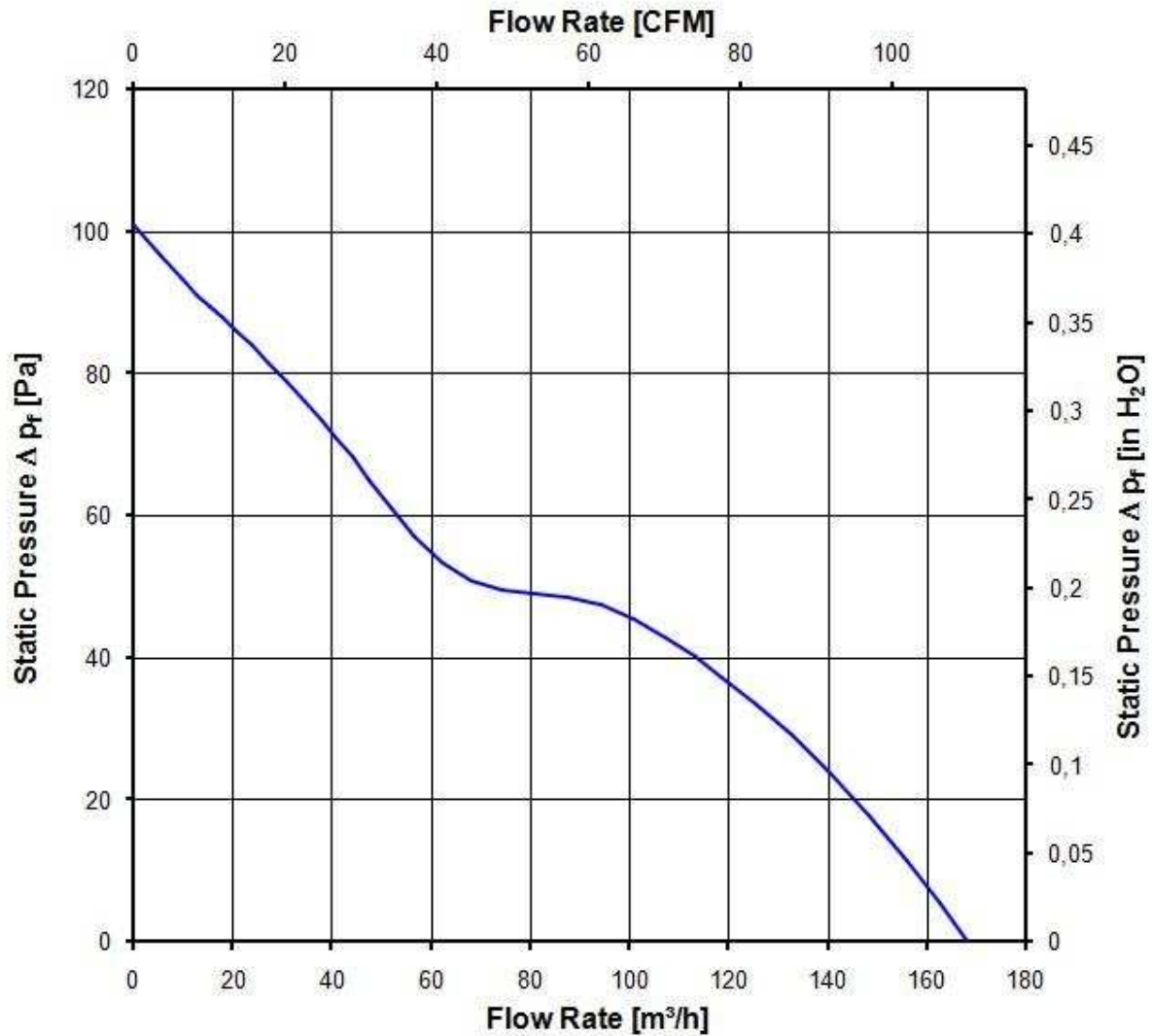



### 3.4 Sound Data

Measurement conditions: Sound pressure level: 1 meter distance between microphone and the air intake.  
 Sound power level: Acc. to DIN 45635 part 38 (ISO 10302)  
 Measured in a semianchoic chamber with a background noise level of  $L_p(A) < 5 \text{ dB(A)}$   
 For further measurement conditions see chapter aerodynamics.

a.) Operation condition:

3.200 1/min at free air flow
------------------------------

Optimal operating point	104,0 m <sup>3</sup> /h @ 40 Pa	
Sound power level at the optimal operating point	5,6 bel(A)	
Sound pressure level at free air flow, measured in rubber bands	49,0 dB(A)	

## 4 Environment

### 4.1 General

Min. permitted ambient temperature TU min.	-20 °C	
Max. permitted ambient temperature TU max.	75 °C	
Min. permitted storage temperature TL min.	-40 °C	
Max. permitted storage temperature TL max.	80 °C	

### 4.2 Climatic Requirements

IP-protection type (certified)	IP 68 (for fan only, not for connector if applicable) **)	
Humidity requirements	humid temperature, cyclic; according to DIN EN 60068-2-38, 10 cycle and condensation water check; according to DIN EN ISO 6270-2, 14 days	
Salt fog requirements	None	

Permitted application area:

The product is for the use in partial sheltered rooms or open, roofed areas. Direct exposure to water is allowed provided that this does not prevent the normal operation. Saline ambient conditions must be avoided.

Pollution degree 3 (according DIN EN 60664-1)

It occurs conductive pollution or dry non-conductive pollution which becomes conductive due to condensation.

\*\*\*) The specification of the IP protection refers to the conditions mentioned in certification of the fan. The above mentioned short description of the protection scope is not final. For detailed information of the respective protection scope and definitions, see certification as well as DIN EN 60529 (protection by housings) and ISO 20653 (for vehicles) with the letter K.

#### **Short description of the IP-protection type:**

Solid particle Protection: Dust tight.

Protection against deliberate contact: Protected against contact to hazardous parts with a wire.

Protection against water: The fan test according to IP68 (Based on IEC 60529), is conducted in non-operating mode. The fan is tested by a complete immersion in water for a period of 2h at a water-level of 1,2m. Electrical connections are not immersed since they are customer specific.

Please require severity levels and specification parameters from the responsible development departments.

**5 Safety**

**5.1 Electrical Safety**

Dielectric strength DIN EN 60950 (VDE 0805) and DIN EN 60335 (VDE 0700) A.) Type test Measuring conditions: After 48h of storage at 95% R.H. and 25°C. No arcing or breakdown is allowed! All connections together to ground.	500 VAC / 1 Min.	
B.) Routine test Measuring conditions: At indoor climate. No arcing or breakdown is allowed! All connections together to ground.	850 VDC / 1 Sec.	
Isolation resistance Measuring conditions: After 48h of storage at 95% R.H. and 25°C measured with U=500 VDC for 1 min.	RI > 10 MOhm	
Clearance / creepage distance	1,0 mm / 1,2 mm	
Protection class	III	

**5.2 Approval Tests**

CE	EC Declaration of Conformity	Yes
EAC	Eurasian Conformity	Yes
UL	Underwriters Laboratories	Yes / UL audited by CSA according to UL507, Electric Fans
VDE	Association for Electrical, Electronic and Information Technologies	Yes / Approval acc. to EN 60950 (VDE 0805) - Information technology equipment
CSA	Canadian Standards Association	Yes / C22.2 No. 113 Fans and Ventilators
CCC	China Compulsory Certification	Not applicable

**6 Reliability**

**6.1 General**

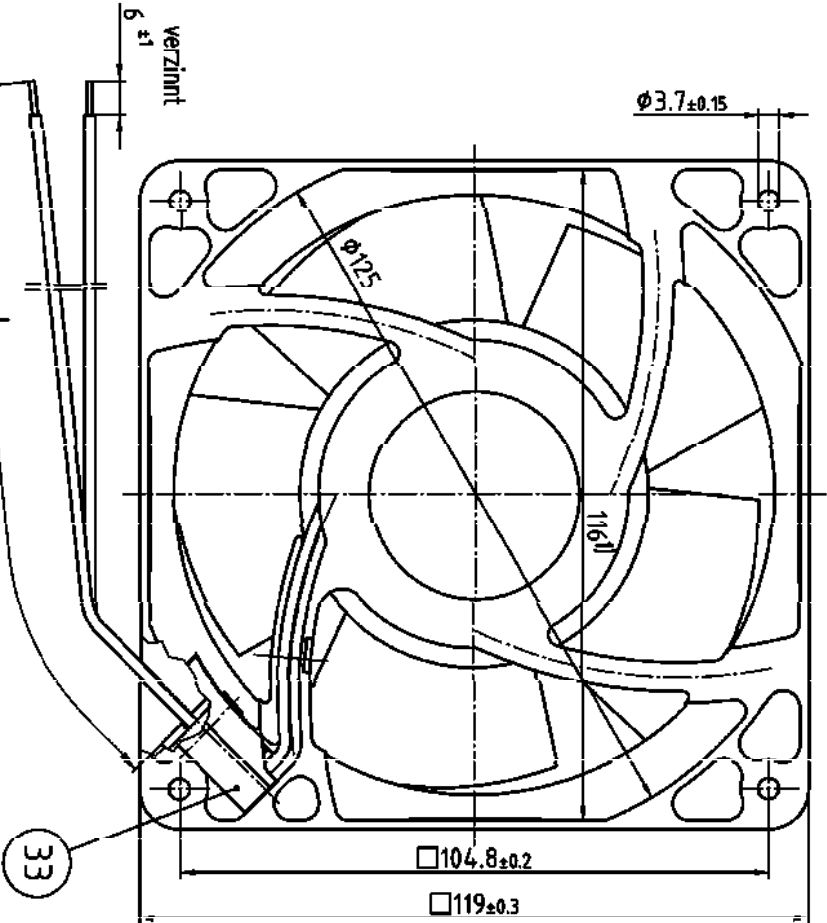
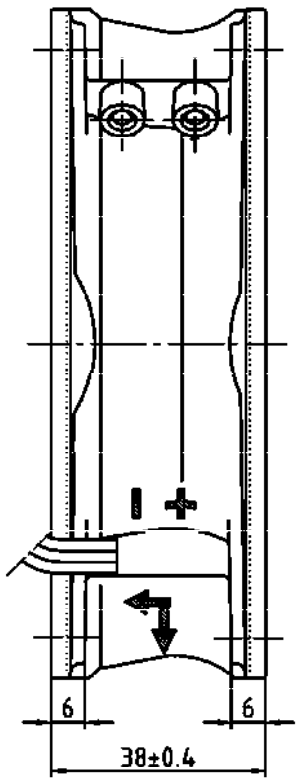

Pos. 33 nur wenn in Stückliste enthalten  
Anzahl und Länge der Lizen s. Bv. Bl. 1

1) Maße für Montagewand  
Auslöser bei  
- Kugellagerung (K): 0 (mit Federzug gleich)  
- Oel-Lagerung (L): 0,1 - 0,6

Tolerierung: DIN 7167		Artikel		Herzfab	
Allgemeintolerenzen: DIN 7167		Längerrunde: DIN ISO 2768-dL		Winkel, Form u. Lage: DIN ISO 2768-dL	
Bearbeitet:		Datum:		Name:	
Indes:		Aemf.-Nr.:			
Begrüßt u. zur Verwendung freigegeben von am					
<p><b>Schmalzwerk</b></p> <p>St. Lorenz 12, Ca. 16</p>		<p>Zeich.-Nr.:</p>		<p>Blatt:</p>	
<p>12</p>		<p>13</p>		<p>14</p>	