

**Table of Contents**

Single Pole, Electrically Held, 1 Amp and Less . . . . .	1-2 – 1-9
1MA, 1MAD, 1MADD . . . . .	1-2, 1-3
1MS, 1MSD, 1MSDD . . . . .	1-4, 1-5
1MAT . . . . .	1-6, 1-7
1MST . . . . .	1-8, 1-9
Double Pole, Electrically Held, 1 Amp and Less . . . . .	1-10 – 1-35
MA, MAD, MADD . . . . .	1-10, 1-11
MS, MSD, MSDD . . . . .	1-12, 1-13
HM, HMD, HS, HSD . . . . .	1-14, 1-15
MGA, MGAD, MGADD . . . . .	1-16, 1-17
MGS, MGSD, MGSDD . . . . .	1-18, 1-19
HC, HCD, HCS, HCSD . . . . .	1-20, 1-21
MAT . . . . .	1-22, 1-23
MST . . . . .	1-24, 1-25
MGAT . . . . .	1-26, 1-27
MGST . . . . .	1-28, 1-29
SMGA, SMGAD, SMGADD . . . . .	1-30, 1-31
SMGS, SMGSD, SMGSDD . . . . .	1-32, 1-33
SHC, SHCD, SHCS, SHCSD . . . . .	1-34, 1-35
Double Pole, Electrically Held, 2 Amps and Less . . . . .	1-36 – 1-46
HFW, HMB, HMS . . . . .	1-36, 1-37
3SCV . . . . .	1-38, 1-39
HFC . . . . .	1-40
3SBC . . . . .	1-41, 1-42
3SCC . . . . .	1-43, 1-44
3SAC, 3SAE . . . . .	1-45, 1-46
Double Pole, Magnetic Latching, 2 Amps and Less . . . . .	1-47 – 1-52
LS . . . . .	1-47, 1-48
3SDM . . . . .	1-49, 1-50
3SAM . . . . .	1-51, 1-52
Four Pole, Electrically Held, 2 Amps and Less . . . . .	1-53 – 1-59
SR . . . . .	1-53, 1-54
3SBH . . . . .	1-55 – 1-57
3SDH . . . . .	1-58, 1-59
Four Pole, Magnetic Latching, 2 Amps and Less . . . . .	1-60 – 1-62
3SBM . . . . .	1-60 – 1-62
Six Pole, Electrically Held, 2 Amps and Less . . . . .	1-63, 1-64
SS . . . . .	1-63, 1-64
Double Pole, Electrically Held, 5 Amps and Less . . . . .	1-65 – 1-69
HFW4A, HFW5A . . . . .	1-65, 1-66
HFC4A, HFC5A . . . . .	1-67
FW, FW5A, SF, SF5A . . . . .	1-68, 1-69
Single Pole, Electrically Held, 10 Amps and Less . . . . .	1-70
C . . . . .	1-70
Double Pole, Electrically Held, 10 Amps and Less . . . . .	1-71, 1-72
07 . . . . .	1-71, 1-72

Single Pole, Electrically Held, 1 Amp and Less

1MA, 1MAD, 1MADD

**1MA**  
**Standard TO-5**  
**High Performance Relay**  
**Qualified to**  
**MIL-R-39016/7**

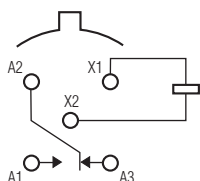

Terminal View

**1MAD**  
**Standard TO-5**  
**Diode Suppressed**  
**High Performance Relay**  
**Qualified to**  
**MIL-R-39016/23**

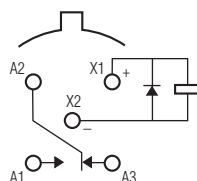

Terminal View

**1MADD**  
**Standard TO-5 Diode**  
**Suppressed/Protected**  
**High Performance Relay**  
**Qualified to**  
**MIL-R-39016/24**

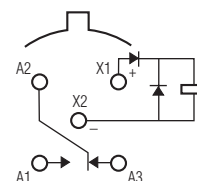

Terminal View

**Product Facts**

- Hermetically sealed
- High shock & vibration ratings
- Spreader pad
- Excellent RF switching

**Product Facts**

- Suppression diode
- Hermetically sealed
- High shock & vibration ratings
- Spreader pad
- Excellent RF switching

**Product Facts**

- Suppression & protection diodes
- Hermetically sealed
- High shock & vibration ratings
- Spreader pad
- Excellent RF switching

**Electrical Characteristics**

**Contact Arrangement** — 1 Form C (SPDT)

**Contact Material** — Stationary — Gold/platinum/palladium/silver alloy (gold plated)  
 Moveable — Gold/platinum/palladium/silver alloy (gold plated)

**Contact Resistance** — Before Life — 100 milliohms max. (measured @ 10 mA @ 6 Vdc)  
 After Life — 200 milliohms max. (measured @ 1 A @ 28 Vdc)

**Mechanical Life Expectancy** — 1 million operations

**Coil Voltage** — 5 to 26.5 Vdc  
**Coil Power** — 512 mW max. @ 25°C  
**Duty Cycle** — Continuous  
**Pick-up Voltage** — Approximately 50% of nominal coil voltage  
**Pick-up Sensitivity** — 100 mW max. @ 25°C

**Contact Ratings**

Contact Load	Type	Operations MINd.
1.0 A @ 28 Vdc	Resistive	100,000
250 mA @ 115 Vac, 60 Hz & 400 Hz	Resistive (case not grounded)	100,000
100 mA @ 115 Vac, 60 Hz & 400 Hz	Resistive	100,000
0.2 A @ 28 Vdc	Inductive (0.32 Henry)	100,000
0.1 A @ 28 Vdc	Lamp	100,000
30 µA @ 50 mVdc	Low Level	1,000,000
0.1 A @ 28 Vdc	Intermediate Current	50,000

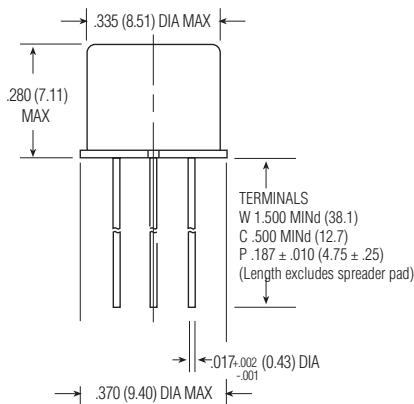

1MA/1MAD/1MADD Enclosure

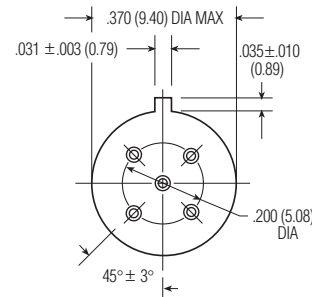

1MA/1MAD/1MADD Header

Single Pole, Electrically Held, 1 Amp and Less (Continued)

1MA, 1MAD, 1MADD

(Continued)

Operating Characteristics

**Timing** —  
Operate Time — 2.0 ms max.  
Release Time —  
1MA — 2.0 ms max.  
1MAD/1MADD — 4.0 ms max.  
(suppression diode, suppression/  
steering diodes)

**Contact Bounce** — 1.5 ms max

**Dielectric Withstanding Voltage** —

Between Open Contacts —  
500 Vrms 60 Hz  
Between Adjacent Contacts —  
500 Vrms 60 Hz  
Between Contacts & Coil —  
500 Vrms 60 Hz

**Insulation Resistance** —

10,000 megohms @ 500 Vdc  
1,000 megohms @ 500 Vdc  
(coil to case @ +125°C)

Environmental Characteristics

**Temperature Range** —  
-65°C to +125°C

**Weight** —  
0.08 oz. (2.27 grms)  
0.09 oz. (2.52 grms) with spreader pad  
attached

**Vibration Resistance** —

30 G's, 10 to 3,000 Hz

**Shock Resistance** —

75 G's, 6 ±1 ms max.

**QPL Approval** —

MIL-R-39016/7 (J1MA)  
MIL-R-39016/23 (J1MAD)  
MIL-R-39016/24 (J1MADD)

Semiconductor Characteristics

**Diode** —  
100 Vdc peak inverse voltage (PIV)  
1.0 Vdc max. transient voltage

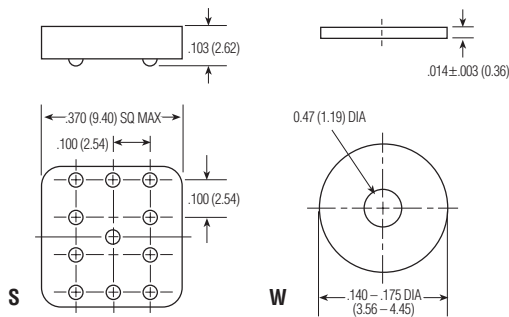

Spreader & Mounting Pads

Coil Data

Nom. Coil Voltage (Vdc)	Coil Resistance in Ohms ±10% @ 25°C (Note 1)	Coil Circuit Current mA (Max.) (Note 1&2)	Coil Circuit Current mA (Min.) (Note 1&2)	Pickup Voltage Vdc (Max.) @ 25°C (Note 2)	Base Turn On Current mA (Max.) @ 25°C	Pickup Voltage Vdc (Max.) @ 125°C (Note 2)	Base Turn On Current mA (Max.) @ 125°C	Drop-Out Voltage Vdc (Min.) @ 25°C (Note 2)	Drop-Out Voltage Vdc (Min.) @ -65°C (Note 2)	Nom. Coil Power (mW) @ 25°C	Max. Coil Voltage	Coil Desig.
1MA/MAD												
5.0	63	n/a	n/a	2.8	n/a	3.7	n/a	0.23	0.15	397	6.0	5
6.0	125	n/a	n/a	3.5	n/a	4.5	n/a	0.28	0.18	288	8.0	6
9.0	280	n/a	n/a	5.3	n/a	6.8	n/a	0.54	0.35	289	12.0	9
12.0	500	n/a	n/a	7.0	n/a	9.0	n/a	0.63	0.40	288	16.0	12
18.0	1,130	n/a	n/a	10.5	n/a	13.5	n/a	0.91	0.58	287	24.0	18
26.5	2,000	n/a	n/a	14.2	n/a	18.0	n/a	1.37	0.89	351	32.0	26
1MADD												
5.0	50	100.0	72.7	3.5	n/a	4.5	n/a	0.23	0.15	500	6.0	5
6.0	98	62.4	46.3	4.1	n/a	5.5	n/a	0.28	0.18	367	8.0	6
9.0	280	33.7	25.9	6.3	n/a	7.8	n/a	0.54	0.35	289	12.0	9
12.0	500	25.6	20.0	8.0	n/a	10.0	n/a	0.63	0.40	288	16.0	12
18.0	1,130	17.2	13.6	11.6	n/a	14.5	n/a	0.91	0.58	287	24.0	18
26.5	2,000	14.4	11.5	15.4	n/a	19.0	n/a	1.37	0.89	351	32.0	26

Notes: 1. Coil resistance not directly measurable. Coil current should be within limits shown when tested at nominal voltage at 25°C for 5 seconds max.  
2. Set base current at 3 mA to 15 mA during measurements.

Ordering Instructions

Catalog-selected Relays: The catalog number is derived by choosing the proper CODE for each of the relay characteristics in the order in which the codes are listed.

Specifying a Part Number Example*:	Type	Terminal	Diodes	Coils	Spreader/Mounting Pads
	1MA	C	D	-26	S

\* The part number example shown on this page is for catalog items. For a list of specific QPL part numbers, please see the index in Section 15.

Single Pole, Electrically Held, 1 Amp and Less (Continued)

1MS, 1MSD, 1MSDD

**1MS**  
Sensitive TO-5  
High Performance Relay  
Qualified to  
MIL-R-39016/10

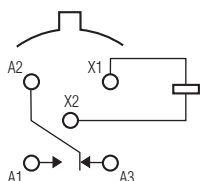

Terminal View

**1MSD**  
Sensitive TO-5  
Diode Suppressed  
High Performance Relay  
Qualified to  
MIL-R-39016/25

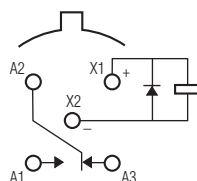

Terminal View

**1MSDD**  
Sensitive TO-5 Diode  
Suppressed/Protected  
High Performance Relay  
Qualified to  
MIL-R-39016/26

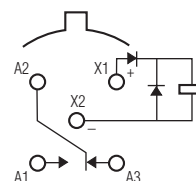

Terminal View

**Product Facts**

- Hermetically sealed
- High shock & vibration ratings
- Spreader pad
- Excellent RF switching

**Product Facts**

- Suppression diode
- Hermetically sealed
- High shock & vibration ratings
- Spreader pad
- Excellent RF switching

**Product Facts**

- Suppression & protection diodes
- Hermetically sealed
- High shock & vibration ratings
- Spreader pad
- Excellent RF switching

**Electrical Characteristics**

**Contact Arrangement** —  
1 Form C (SPDT)

**Contact Material** —  
Stationary —  
Gold/platinum/palladium/silver alloy  
(gold plated)  
Moveable —  
Gold/platinum/palladium/silver alloy  
(gold plated)

**Contact Resistance** —  
Before Life — 100 milliohms max.  
(measured @ 10 mA @ 6 Vdc)  
After Life — 200 milliohms max.  
(measured @ 1 A @ 28 Vdc)

**Mechanical Life Expectancy** —  
1 million operations

**Coil Voltage** — 5 to 40 Vdc

**Coil Power** — 506 mW max. @ 25°C

**Duty Cycle** — Continuous

**Pick-up Voltage** — Approximately  
50% of nominal coil voltage

**Pick-up Sensitivity** —  
40 mW max. @ 25°C

**Contact Ratings**

Contact Load	Type	Operations MINd.
1.0 A @ 28 Vdc	Resistive	100,000
250 mA @ 115 Vac, 60 Hz & 400 Hz	Resistive (case not grounded)	100,000
100 mA @ 115 Vac, 60 Hz & 400 Hz	Resistive	100,000
0.2 A @ 28 Vdc	Inductive (0.32 Henry)	100,000
0.1 A @ 28 Vdc	Lamp	100,000
30 µA @ 50 mVdc	Low Level	1,000,000
0.1 A @ 28 Vdc	Intermediate Current	50,000

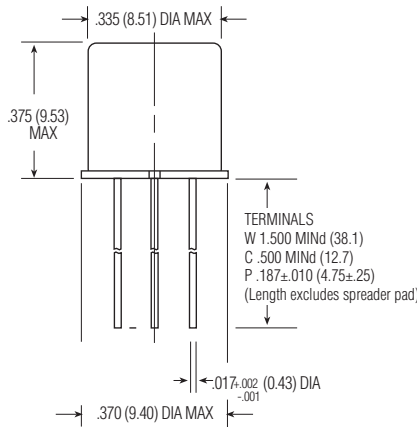

1MS/1MSD/1MSDD Enclosure

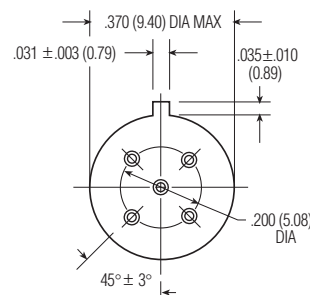

1MS/1MSD/1MSDD Header

**Single Pole, Electrically Held, 1 Amp and Less** (Continued)

**1MS, 1MSD, 1MSDD**  
(Continued)

**Operating Characteristics**

**Timing** —  
Operate Time — 4.0 ms max.  
Release Time —  
1MS — 2.5 ms max.  
1MSD/1MSDD — 7.5 ms max.  
(suppression diode, suppression/  
steering diodes)  
**Contact Bounce** — 1.5 ms max  
**Dielectric Withstanding Voltage** —  
Between Open Contacts —  
500 Vrms 60 Hz  
Between Adjacent Contacts —  
500 Vrms 60 Hz  
Between Contacts & Coil —  
500 Vrms 60 Hz  
**Insulation Resistance** —  
10,000 megohms @ 500 Vdc  
1,000 megohms @ 500 Vdc  
(coil to case @ +125°C)

**Environmental Characteristics**

**Temperature Range** —  
-65°C to +125°C  
**Weight** —  
0.10 oz. (2.84 grms)  
0.11 oz. (3.09 grms) with spreader pad  
attached  
**Vibration Resistance** —  
30 G's, 10 to 3,000 Hz  
**Shock Resistance** —  
75 G's, 6 ±1 ms max.  
**QPL Approval** —  
MIL-R-39016/10 (J1MS)  
MIL-R-39016/25 (J1MSD)  
MIL-R-39016/26 (J1MSDD)

**Semiconductor Characteristics**

**Diode** —  
100 Vdc peak inverse voltage (PIV)  
1.0 Vdc max. transient voltage

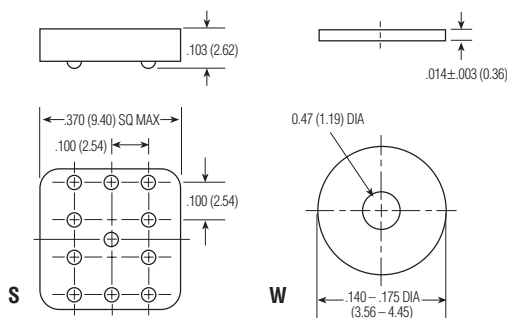

Spreader & Mounting Pads

**Coil Data**

Nom. Coil Voltage (Vdc)	Coil Resistance in Ohms ±10% @ 25°C (Note 1)	Coil Circuit Current mA (Max.) (Note 1&2)	Coil Circuit Current mA (MINd) (Note 1&2)	Pickup Voltage Vdc (Max.) @ 25°C (Note 2)	Base Turn On Current mA (Max.) @ 25°C	Pickup Voltage Vdc (Max.) @ 125°C (Note 2)	Base Turn On Current mA (Max.) @ 125°C	Drop-Out Voltage Vdc (MINd) @ 25°C (Note 2)	Drop-Out Voltage Vdc (MINd) @ -65°C (Note 2)	Nom. Coil Power (mW) @ 25°C	Max. Coil Voltage	Coil Desig.
<b>1MS/MSD</b>												
5.0	125	n/a	n/a	2.8	n/a	3.7	n/a	0.23	0.15	200	8.0	5
6.0	255	n/a	n/a	3.5	n/a	4.5	n/a	0.28	0.18	141	11.0	6
9.0	630	n/a	n/a	5.3	n/a	6.8	n/a	0.54	0.35	129	12.0	9
12.0	1,025	n/a	n/a	7.0	n/a	9.0	n/a	0.63	0.40	140	22.0	12
18.0	2,300	n/a	n/a	10.5	n/a	13.5	n/a	0.91	0.59	141	24.0	18
26.5	4,000	n/a	n/a	14.2	n/a	18.0	n/a	1.37	0.89	176	45.0	26
32.0	6,500	n/a	n/a	18.7	n/a	24.0	n/a	1.59	1.0	158	57.0	32
40.0	11,000	n/a	n/a	23.3	n/a	30.0	n/a	2.0	1.3	145	75.0	40
<b>1MSDD</b>												
5.0	100	50.0	36.3	3.5	n/a	4.5	n/a	0.23	0.15	250	8.0	5
6.0	200	30.6	22.7	4.1	n/a	5.5	n/a	0.28	0.18	180	11.0	6
9.0	630	15.0	11.5	6.3	n/a	7.8	n/a	0.54	0.35	129	16.0	9
12.0	1,025	12.5	9.7	8.0	n/a	10.0	n/a	0.63	0.40	140	22.0	12
18.0	2,300	8.5	6.7	11.6	n/a	14.5	n/a	0.91	0.58	141	33.0	18
26.5	4,000	7.2	5.7	15.4	n/a	19.0	n/a	1.37	0.89	176	45.0	26
32.0	6,500	5.4	4.3	17.0	n/a	21.0	n/a	1.5	0.95	158	57.0	32
40.0	11,000	4.0	3.2	22.0	n/a	27.0	n/a	2.0	1.28	145	75.0	40

**Notes:** 1. Coil resistance not directly measurable. Coil current should be within limits shown when tested at nominal voltage at 25°C for 5 seconds max.  
2. Set base current at 3 mA to 15 mA during measurements.

**Ordering Instructions**

Catalog-selected Relays: The catalog number is derived by choosing the proper CODE for each of the relay characteristics in the order in which the codes are listed.

**Specifying a Part Number Example:**

<b>Type</b>	<b>Terminal</b>	<b>Diodes</b>	<b>Coils</b>	<b>Spreader/Mounting Pads</b>
1MS	C	D	-26	S

\* The part number example shown on this page is for catalog items. For a list of specific QPL part numbers, please see the index in Section 15.

Single Pole, Electrically Held, 1 Amp and Less (Continued)

1MAT

**1MAT**  
**Standard TO-5**  
**Diode Suppressed/  
 Transistor Driven**  
**High Performance Relay**  
**Qualified to  
 MIL-R-28776/5**

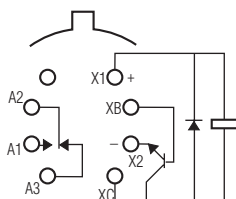

Terminal View

**Product Facts**

- Transistor driver & suppression diode
- Hermetically sealed
- High shock & vibration ratings
- Spreader pad
- Excellent RF switching

**Electrical Characteristics**

**Contact Arrangement** —  
 1 Form C (SPDT)

**Contact Material** —  
 Stationary —  
 Gold/platinum/palladium/silver alloy  
 (gold plated)  
 Moveable —  
 Gold/platinum/palladium/silver alloy  
 (gold plated)

**Contact Resistance** —  
 Before Life — 100 milliohms max.  
 (measured @ 10 mA @ 6 Vdc)  
 After Life — 200 milliohms max.  
 (measured @ 1 A @ 28 Vdc)

**Mechanical Life Expectancy** —  
 1 million operations

**Coil Voltage** — 5 to 26.5 Vdc

**Coil Power** — 512 mW max. @ 25°C

**Duty Cycle** — Continuous

**Pick-up Voltage** — Approximately  
 50% of nominal coil voltage

**Pick-up Sensitivity** —  
 100 mW max. @ 25°C

**Contact Ratings**

Contact Load	Type	Operations MIND.
1.0 A @ 28 Vdc	Resistive	100,000
250 mA @ 115 Vac, 60 Hz & 400 Hz	Resistive (case not grounded)	100,000
100 mA @ 115 Vac, 60 Hz & 400 Hz	Resistive	100,000
0.2 A @ 28 Vdc	Inductive (0.32 Henry)	100,000
0.1 A @ 28 Vdc	Lamp	100,000
30 µA @ 50 mVdc	Low Level	1,000,000
0.1 A @ 28 Vdc	Intermediate Current	50,000

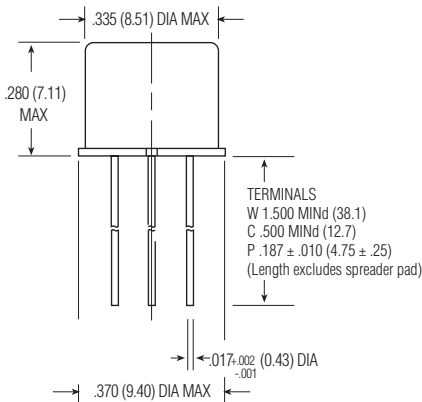

1MAT Enclosure

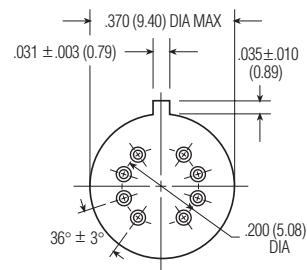

1MAT Header

**Single Pole, Electrically Held, 1 Amp and Less** (Continued)

**1MAT** (Continued)

**Operating Characteristics**

**Timing** —  
Operate Time — 2.0 ms max.  
Release Time —  
4.0 ms max.  
**Contact Bounce** — 1.5 ms max  
**Dielectric Withstanding Voltage** —  
Between Open Contacts —  
500 Vrms 60 Hz  
Between Adjacent Contacts —  
500 Vrms 60 Hz  
Between Contacts & Coil —  
500 Vrms 60 Hz  
**Insulation Resistance** —  
10,000 megohms @ 500 Vdc  
1,000 megohms @ 500 Vdc  
(coil to case @ +125°C)

**Environmental Characteristics**

**Temperature Range** —  
-65°C to +125°C  
**Weight** —  
0.08 oz. (2.27 grms)  
0.09 oz. (2.52 grms) with spreader pad attached  
**Vibration Resistance** —  
30 G's, 10 to 3,000 Hz  
**Shock Resistance** —  
75 G's, 6 ±1 ms max.  
**QPL Approval** —  
MIL-R-28776/5 (J1MAT)

**Semiconductor Characteristics**

**Diode** —  
100 Vdc peak inverse voltage (PIV)  
1.0 Vdc max. transient voltage  
**Transistor** —  
0.3 Vdc MINd. base turn off voltage;  
6.0 Vdc min. emitter-base breakdown  
voltage (BV<sub>EB0</sub>) @ 25°C;  
80.0 Vdc min. collector-base breakdown  
voltage (BV<sub>CB0</sub>) @ 25°C & I<sub>C</sub>=100 µA

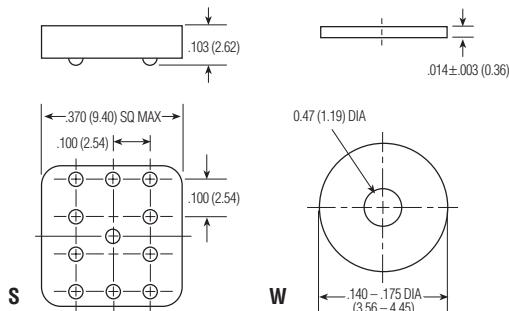

Spreader & Mounting Pads

**Coil Data**

Nom. Coil Voltage (Vdc)	Coil Resistance in Ohms ±10% @ 25°C (Note 1)	Coil Circuit Current mA (Max.) (Note 1&2)	Coil Circuit Current mA (MINd) (Note 1&2)	Pickup Voltage Vdc (Max.) @ 25°C (Note 2)	Base Turn On Current mA (Max.) @ 25°C	Pickup Voltage Vdc (Max.) @ 125°C (Note 2)	Base Turn On Current mA (Max.) @ 125°C	Drop-Out Voltage Vdc (MINd) @ 25°C (Note 2)	Drop-Out Voltage Vdc (MINd) @ -65°C (Note 2)	Nom. Coil Power (mW) @ 25°C	Max. Coil Voltage	Coil Desig.
1MAT												
5.0	63	89.6	66.6	3.0	0.60	3.9	2.38	0.24	0.15	397	5.8	5
6.0	125	55.5	42.0	3.8	0.42	5.2	1.60	0.31	0.18	288	8.0	6
9.0	280	38.1	28.0	5.6	0.27	7.8	1.07	0.47	0.35	289	12.0	9
12.0	500	28.1	20.9	7.2	0.21	10.0	0.80	0.62	0.40	288	16.0	12
18.0	1,130	18.8	13.8	10.7	0.12	14.5	0.53	0.94	0.58	287	24.0	18
26.5	2,000	15.5	11.5	14.4	0.10	19.0	0.40	1.25	0.89	351	32.0	26

**Notes:** 1. Coil resistance not directly measurable. Coil current should be within limits shown when tested at nominal voltage at 25°C for 5 seconds max.  
2. Set base current at 3 mA to 15 mA during measurements.

**Ordering Instructions**

Catalog-selected Relays: The catalog number is derived by choosing the proper CODE for each of the relay characteristics in the order in which the codes are listed.

<b>Specifying a Part Number Example:</b>	<b>Type</b>	<b>Terminal</b>	<b>Diodes</b>	<b>Coils</b>	<b>Spreader/Mounting Pads</b>
	1MA	C	T	-26	S

\* The part number example shown on this page is for catalog items. For a list of specific QPL part numbers, please see the index in Section 15.

Single Pole, Electrically Held, 1 Amp and Less (Continued)

1MST

**1MST**  
**Sensitive T0-5**  
**Diode Suppressed/**  
**Transistor Driven**  
**High Performance Relay**  
**Qualified to MIL-R-28776/4**

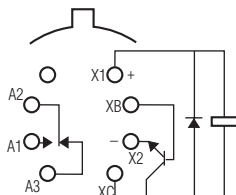

Terminal View

**Product Facts**

- Transistor driver & suppression diode
- Hermetically sealed
- High shock & vibration ratings
- Spreader pad
- Excellent RF switching

**Electrical Characteristics**

**Contact Arrangement** — 1 Form C (SPDT)  
**Contact Material** — Stationary — Gold/platinum/palladium/silver alloy (gold plated)  
 Moveable — Gold/platinum/palladium/silver alloy (gold plated)

**Contact Resistance** — Before Life — 100 milliohms max. (measured @ 10 mA @ 6 Vdc)  
 After Life — 200 milliohms max. (measured @ 1 A @ 28 Vdc)

**Mechanical Life Expectancy** — 1 million operations

**Coil Voltage** — 5 to 40 Vdc  
**Coil Power** — 506 mW max. @ 25°C  
**Duty Cycle** — Continuous  
**Pick-up Voltage** — Approximately 50% of nominal coil voltage  
**Pick-up Sensitivity** — 40 mW max. @ 25°C

**Contact Ratings**

1.0 A @ 28 Vdc	Resistive	100,000
250 mA @ 115 Vac, 60 Hz & 400 Hz	Resistive (case not grounded)	100,000
100 mA @ 115 Vac, 60 Hz & 400 Hz	Resistive	100,000
0.2 A @ 28 Vdc	Inductive (0.32 Henry)	100,000
0.1 A @ 28 Vdc	Lamp	100,000
30 µA @ 50 mVdc	Low Level	1,000,000
0.1 A @ 28 Vdc	Intermediate Current	50,000

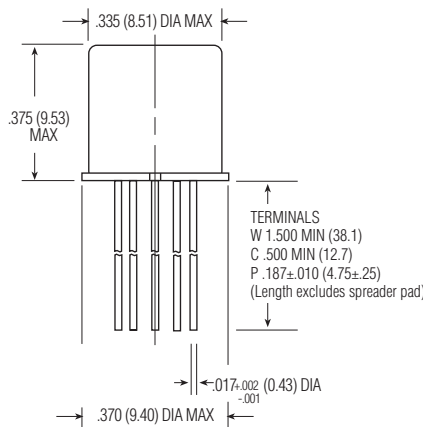

1MST Enclosure

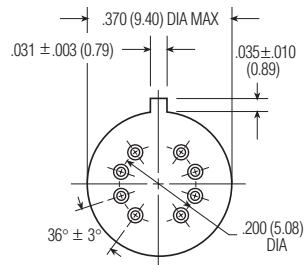

1MST Header

Single Pole, Electrically Held, 1 Amp and Less (Continued)

1MST (Continued)

Operating Characteristics

**Timing** —  
 Operate Time — 3.5 ms max.  
 Release Time — 7.5 ms max.  
**Contact Bounce** — 1.5 ms max  
**Dielectric Withstanding Voltage** —  
 Between Open Contacts — 500 Vrms 60 Hz  
 Between Adjacent Contacts — 500 Vrms 60 Hz  
 Between Contacts & Coil — 500 Vrms 60 Hz  
**Insulation Resistance** —  
 10,000 megohms @ 500 Vdc  
 1,000 megohms @ 500 Vdc (coil to case @ +125°C)

Environmental Characteristics

**Temperature Range** — -65°C to +125°C  
**Weight** —  
 0.10 oz. (2.84 grms)  
 0.11 oz. (3.09 grms) with spreader pad attached  
**Vibration Resistance** — 30 G's, 10 to 3,000 Hz  
**Shock Resistance** — 75 G's, 6 ±1 ms max.  
**QPL Approval** — MIL-R-28776/4 (J1MST)

Semiconductor Characteristics

**Diode** —  
 100 Vdc peak inverse voltage (PIV)  
 1.0 Vdc max. transient voltage  
**Transistor** —  
 0.3 Vdc min. base turn off voltage;  
 6.0 Vdc min. emitter-base breakdown voltage (BV<sub>EBO</sub>) @ 25°C;  
 80.0 Vdc min. collector-base breakdown voltage (BV<sub>CBO</sub>) @ 25°C & I<sub>C</sub>=100 µA

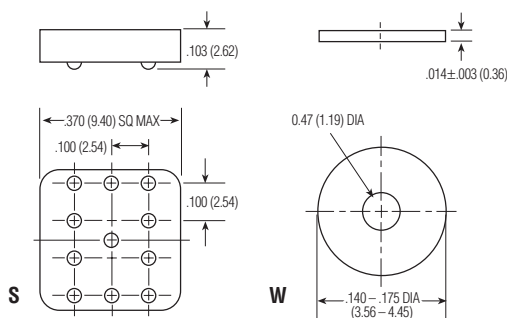

Spreader & Mounting Pads

Coil Data

Nom. Coil Voltage (Vdc)	Coil Resistance in Ohms ±10% @ 25°C (Note 1)	Coil Circuit Current mA (Max.) (Note 1&2)	Coil Circuit Current mA (Min.) (Note 1&2)	Pickup Voltage Vdc (Max.) @ 25°C (Note 2)	Base Turn On Current mA (Max.) @ 25°C	Pickup Voltage Vdc (Max.) @ 125°C (Note 2)	Base Turn On Current mA (Max.) @ 125°C	Drop-Out Voltage Vdc (Min.) @ 25°C (Note 2)	Drop-Out Voltage Vdc (Min.) @ -65°C (Note 2)	Nom. Coil Power (mW) @ 25°C	Max. Coil Voltage	Coil Desig.
1MST												
5.0	125	47.8	34.7	2.6	0.28	3.6	1.20	0.22	0.15	200	8.0	5
6.0	255	27.7	21.2	3.5	0.20	4.8	0.78	0.28	0.18	141	11.0	6
9.0	630	16.8	11.8	5.4	0.13	7.8	0.48	0.54	0.35	129	16.0	9
12.0	1,025	13.6	10.1	6.6	0.10	10.0	0.39	0.63	0.41	140	22.0	12
18.0	2,300	9.1	6.7	9.8	0.07	14.5	0.26	0.91	0.58	141	33.0	18
26.5	4,000	7.7	5.7	12.8	0.05	19.0	0.20	1.37	0.89	176	45.0	26
32.0	6,500	5.8	4.2	18.7	0.04	24.0	0.16	1.60	1.00	158	57.0	32
40.0	11,000	4.3	3.1	23.3	0.03	30.0	0.13	2.10	1.30	145	75.0	40

Notes: 1. Coil resistance not directly measurable. Coil current should be within limits shown when tested at nominal voltage at 25°C for 5 seconds max.  
 2. Set base current at 3 mA to 15 mA during measurements.

Ordering Instructions

Catalog-selected Relays: The catalog number is derived by choosing the proper CODE for each of the relay characteristics in the order in which the codes are listed.

Specifying a Part Number Example:

**Type** 1MS      **Terminal** C      **Diodes** T      **Coils** -26      **Spreader/Mounting Pads** S

\* The part number example shown on this page is for catalog items. For a list of specific QPL part numbers, please see the index in Section 15.

## Double Pole, Electrically Held, 1 Amp and Less

MA, MAD, MADD

**MA**  
Standard TO-5  
High Performance Relay  
Qualified to  
MIL-R-39016/9

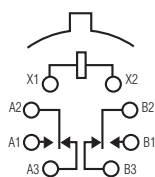

Terminal View

**MAD**  
Standard TO-5  
Diode Suppressed  
High Performance Relay  
Qualified to  
MIL-R-39016/15

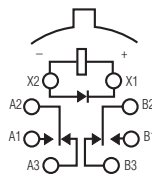

Terminal View

**MADD**  
Standard TO-5 Diode  
Suppressed/Protected  
High Performance Relay  
Qualified to  
MIL-R-39016/20

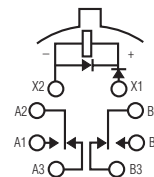

Terminal View

### Product Facts

- Hermetically sealed
- High shock & vibration ratings
- Spreader pads
- Excellent RF switching

### Product Facts

- Suppression diode
- Hermetically sealed
- High shock & vibration ratings
- Spreader pads
- Excellent RF switching

### Product Facts

- Suppression & protection diodes
- Hermetically sealed
- High shock & vibration ratings
- Spreader pads
- Excellent RF switching

### Electrical Characteristics

**Contact Arrangement** —  
2 Form C (DPDT)

**Contact Material** —  
Stationary —  
Gold/platinum/palladium/silver alloy  
(gold plated)  
Moveable —  
Gold/platinum/palladium/silver alloy  
(gold plated)

**Contact Resistance** —  
Before Life — 100 milliohms max.  
(measured @ 10 mA @ 6 Vdc)  
After Life — 200 milliohms max.  
(measured @ 1 A @ 28 Vdc)

**Mechanical Life Expectancy** —  
1 million operations

**Coil Voltage** —  
5 to 30 Vdc (MA/MAD)  
5 to 26.5 Vdc (MADD)

**Coil Power** — 675 mW max. @ 25°C

**Duty Cycle** — Continuous

**Pick-up Voltage** — Approximately  
50% of nominal coil voltage

**Pick-up Sensitivity** —  
130 mW max. @ 25°C

### Contact Ratings

Contact Load	Type	Operations Min.
1.0 A @ 28 Vdc	Resistive	100,000
250 mA @ 115 Vac, 60 Hz & 400 Hz	Resistive (case not grounded)	100,000
100 mA @ 115 Vac, 60 Hz & 400 Hz	Resistive	100,000
0.2 A @ 28 Vdc	Inductive (0.32 Henry)	100,000
0.1 A @ 28 Vdc	Lamp	100,000
30 µA @ 50 mVdc	Low Level	1,000,000
0.1 A @ 28 Vdc	Intermediate Current	50,000

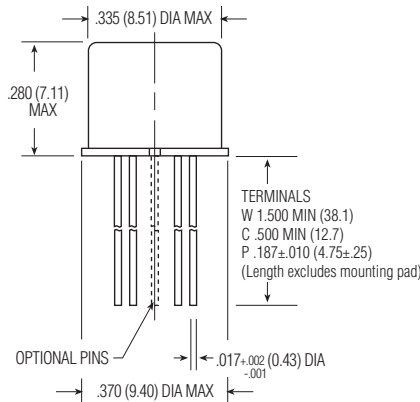

Enclosure

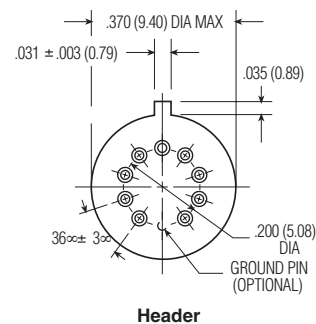

Double Pole, Electrically Held, 1 Amp and Less (Continued)

MA, MAD, MADD (Continued)

Operating Characteristics

**Timing** —  
Operate Time — 2.0 ms max.  
Release Time —  
MA — 1.5 ms max.  
MAD/MADD — 4.0 ms max.  
(suppression diode, suppression/  
steering diodes)

**Contact Bounce** — 1.5 ms max

**Dielectric Withstanding Voltage** —

Between Open Contacts —  
500 Vrms 60 Hz  
Between Adjacent Contacts —  
500 Vrms 60 Hz  
Between Contacts & Coil —  
500 Vrms 60 Hz

**Insulation Resistance** —

10,000 megohms min. @ 500 Vdc  
1,000 megohms @ 500 Vdc  
(coil to case @ +125°C)

Environmental Characteristics

**Temperature Range** —  
-65°C to +125°C

**Weight** —  
0.09 oz. (2.55 grms)  
0.10 oz. (2.80 grms) with spreader pad  
attached

**Vibration Resistance** —

30 G's, 10 to 3,000 Hz

**Shock Resistance** —

75 G's, 6 ±1 ms max.

**QPL Approval** —

MIL-R-39016/9 (JMA)  
MIL-R-39016/15 (JMAD)  
MIL-R-39016/20 (JMADD)

Semiconductor Characteristics

**Diode** —  
100 Vdc peak inverse voltage (PIV)  
1.0 Vdc max. transient voltage

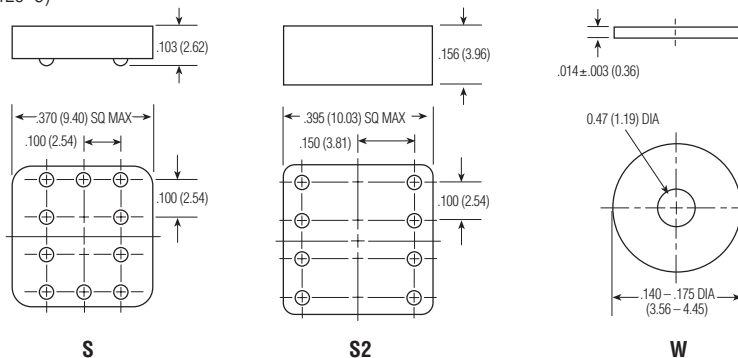

Spreader & Mounting Pads

Coil Data

Nom. Coil Voltage (Vdc)	Coil Resistance in Ohms ±10% @ 25°C (Note 1)	Coil Circuit Current mA (Max.) (Note 1&2)	Coil Circuit Current mA (Min.) (Note 1&2)	Pickup Voltage Vdc (Max.) @ 25°C (Note 2)	Base Turn On Current mA (Max.) @ 25°C	Pickup Voltage Vdc (Max.) @ 125°C (Note 2)	Base Turn On Current mA (Max.) @ 125°C	Drop-Out Voltage Vdc (Min.) @ 25°C (Note 2)	Drop-Out Voltage Vdc (Min.) @ -65°C (Note 2)	Nom. Coil Power (mW) @ 25°C	Max. Coil Voltage	Coil Desig.
MA/MAD												
5.0	50	n/a	n/a	2.7	n/a	3.5	n/a	0.22	0.14	500	5.8	5
6.0	98	n/a	n/a	3.5	n/a	4.5	n/a	0.28	0.18	367	8.0	6
9.0	220	n/a	n/a	5.3	n/a	6.8	n/a	0.54	0.35	368	12.0	9
12.0	390	n/a	n/a	7.0	n/a	9.0	n/a	0.63	0.41	369	16.0	12
18.0	880	n/a	n/a	10.5	n/a	13.5	n/a	0.91	0.59	368	24.0	18
26.5	1,560	n/a	n/a	14.2	n/a	18.0	n/a	1.37	0.89	450	32.0	26
30.0	2,500	n/a	n/a	17.7	n/a	22.0	n/a	1.50	1.00	360	36.0	30
MADD												
5.0	39	128.2	93.2	3.2	n/a	4.0	n/a	0.6	0.6	641	5.8	5
6.0	78	78.3	58.3	4.0	n/a	5.0	n/a	0.7	0.7	462	8.0	6
9.0	220	42.9	33.0	6.3	n/a	7.8	n/a	0.9	0.8	368	12.0	9
12.0	390	32.8	25.6	8.0	n/a	10.0	n/a	1.1	0.9	369	16.0	12
18.0	880	22.1	17.5	11.5	n/a	14.5	n/a	1.4	1.1	368	24.0	18
26.5	1,560	18.5	14.8	15.2	n/a	19.0	n/a	1.8	1.4	450	32.0	26

**Notes:** 1. Coil resistance not directly measurable. Coil current should be within limits shown when tested at nominal voltage at 25°C for 5 seconds max.  
2. Set base current at 3 mA to 15 mA during measurements.

Ordering Instructions

Catalog-selected Relays: The catalog number is derived by choosing the proper CODE for each of the relay characteristics in the order in which the codes are listed.

Specifying a Part Number Example:

Type	Terminal	Diodes	Ground Pins	Coils	Spreader/Mounting Pads
MA	C	D	G	-26	S

\* The part number example shown on this page is for catalog items. For a list of specific QPL part numbers, please see the index in Section 15.

Double Pole, Electrically Held, 1 Amp and Less (Continued)

MS, MSD, MSDD

**MS**  
Sensitive TO-5  
High Performance Relay  
Qualified to  
MIL-R-39016/11

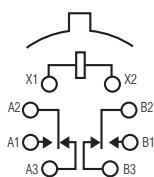

Terminal View

**MSD**  
Sensitive TO-5  
Diode Suppressed  
High Performance Relay  
Qualified to  
MIL-R-39016/16

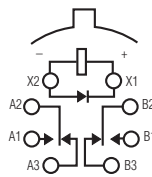

Terminal View

**MSDD**  
Sensitive TO-5 Diode  
Suppressed/Protected  
High Performance Relay  
Qualified to  
MIL-R-39016/21

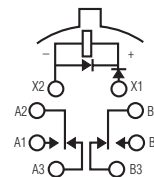

Terminal View

**Product Facts**

- Hermetically sealed
- High shock & vibration ratings
- Spreader pads
- Excellent RF switching

**Product Facts**

- Suppression diode
- Hermetically sealed
- High shock & vibration ratings
- Spreader pads
- Excellent RF switching

**Product Facts**

- Suppression & protection diodes
- Hermetically sealed
- High shock & vibration ratings
- Spreader pads
- Excellent RF switching

**Electrical Characteristics**

**Contact Arrangement** — 2 Form C (DPDT)

**Contact Material** — Stationary — Gold/platinum/palladium/silver alloy (gold plated)  
Moveable — Gold/platinum/palladium/silver alloy (gold plated)

**Contact Resistance** — Before Life — 100 milliohms max. (measured @ 10 mA @ 6 Vdc)  
After Life — 200 milliohms max. (measured @ 1 A @ 28 Vdc)

**Mechanical Life Expectancy** — 1 million operations

**Coil Voltage** — 5 to 48 Vdc  
**Coil Power** — 565 mW max. @ 25°C  
**Duty Cycle** — Continuous

**Pick-up Voltage** — Approximately 50% of nominal coil voltage  
**Pick-up Sensitivity** — 60 mW max. @ 25°C

**Contact Ratings**

Contact Load	Type	Operations Min.
1.0 A @ 28 Vdc	Resistive	100,000
250 mA @ 115 Vac, 60 Hz & 400 Hz	Resistive (case not grounded)	100,000
100 mA @ 115 Vac, 60 Hz & 400 Hz	Resistive	100,000
0.2 A @ 28 Vdc	Inductive (0.32 Henry)	100,000
0.1 A @ 28 Vdc	Lamp	100,000
30 µA @ 50 mVdc	Low Level	1,000,000
0.1 A @ 28 Vdc	Intermediate Current	50,000

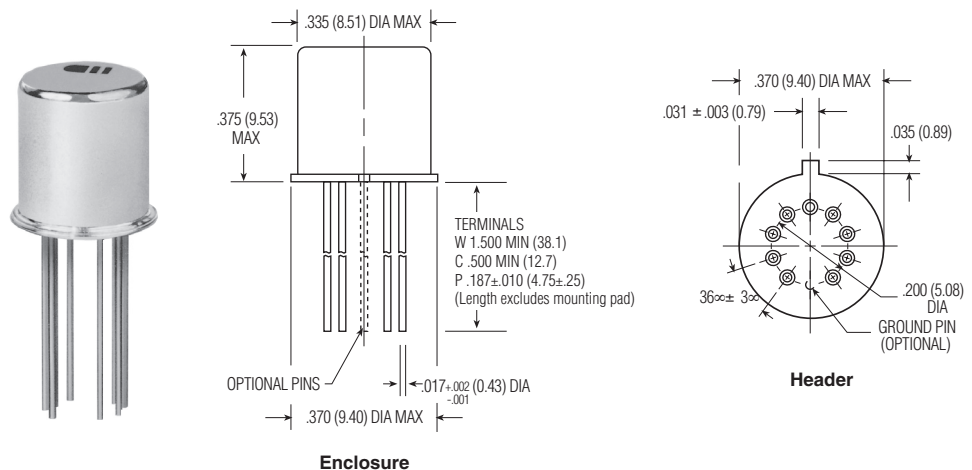

Double Pole, Electrically Held, 1 Amp and Less (Continued)

MS, MSD, MSDD (Continued)

Operating Characteristics

**Timing** —  
 Operate Time — 4.0 ms max.  
 Release Time —  
 MS — 2.0 ms max.  
 MSD/MSDD — 7.5 ms max.  
 (suppression diode, suppression/steering diodes)  
**Contact Bounce** — 1.5 ms max  
**Dielectric Withstanding Voltage** —  
 Between Open Contacts —  
 500 Vrms 60 Hz  
 Between Adjacent Contacts —  
 500 Vrms 60 Hz  
 Between Contacts & Coil —  
 500 Vrms 60 Hz  
**Insulation Resistance** —  
 10,000 megohms min. @ 500 Vdc  
 1,000 megohms @ 500 Vdc  
 (coil to case @ +125°C)

Environmental Characteristics

**Temperature Range** —  
 -65°C to +125°C  
**Weight** —  
 0.12 oz. (3.40 grms)  
 0.13 oz. (3.45 grms) with spreader pad attached  
**Vibration Resistance** —  
 30 G's, 10 to 3,000 Hz  
**Shock Resistance** —  
 75 G's, 6 ±1 ms max.  
**QPL Approval** —  
 MIL-R-39016/11 (JMS)  
 MIL-R-39016/16 (JMSD)  
 MIL-R-39016/21 (JMSDD)

Semiconductor Characteristics

**Diode** —  
 100 Vdc peak inverse voltage (PIV)  
 1.0 Vdc max. transient voltage

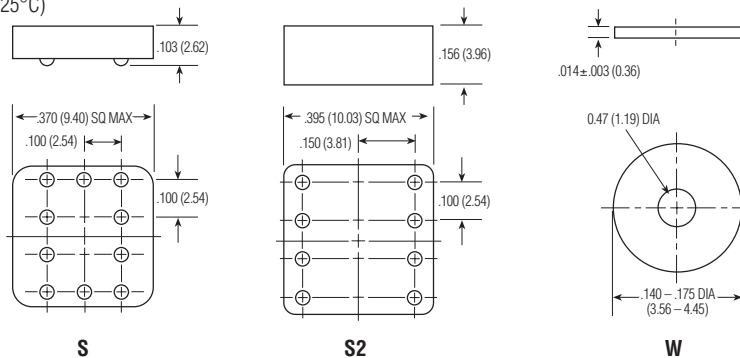

Coil Data

Nom. Coil Voltage (Vdc)	Coil Resistance in Ohms ±10% @ 25°C (Note 1)	Coil Circuit Current mA (Max.) (Note 1&2)	Coil Circuit Current mA (Min.) (Note 1&2)	Pickup Voltage Vdc (Max.) @ 25°C (Note 2)	Base Turn On Current mA (Max.) @ 25°C	Pickup Voltage Vdc (Max.) @ 125°C (Note 2)	Base Turn On Current mA (Max.) @ 125°C	Drop-Out Voltage Vdc (Min.) @ 25°C (Note 2)	Drop-Out Voltage Vdc (Min.) @ -65°C (Note 2)	Nom. Coil Power (mW) @ 25°C	Max. Coil Voltage	Coil Desig.
MS/MSD												
5.0	100	n/a	n/a	2.6	n/a	3.5	n/a	0.23	0.12	250	7.5	5
6.0	200	n/a	n/a	3.4	n/a	4.5	n/a	0.28	0.18	180	10.0	6
9.0	400	n/a	n/a	4.85	n/a	6.8	n/a	0.55	0.35	203	15.0	9
12.0	850	n/a	n/a	7.0	n/a	9.0	n/a	0.64	0.41	169	20.0	12
18.0	1,600	n/a	n/a	9.8	n/a	13.5	n/a	0.92	0.59	203	30.0	18
26.5	3,300	n/a	n/a	14.0	n/a	18.0	n/a	1.4	0.89	213	40.0	26
36.0	6,500	n/a	n/a	20.0	n/a	27.0	n/a	1.8	1.25	199	57.0	36
48.0	11,000	n/a	n/a	25.8	n/a	36.0	n/a	2.4	1.60	209	75.0	48
MSDD												
5.0	64	78.1	56.8	2.9	n/a	3.7	n/a	0.8	0.7	391	7.0	5
6.0	125	48.9	36.3	4.0	n/a	4.8	n/a	0.9	0.8	288	10.0	6
9.0	400	23.6	18.1	6.1	n/a	8.0	n/a	1.1	0.9	203	15.0	9
12.0	850	15.0	11.7	7.8	n/a	11.0	n/a	1.3	1.0	169	20.0	12
18.0	1,600	12.2	9.6	11.3	n/a	14.5	n/a	1.5	1.1	203	30.0	18
26.5	3,300	8.8	7.0	15.2	n/a	19.0	n/a	1.7	1.3	213	40.0	26
36.0	6,500	6.1	4.9	21.7	n/a	27.2	n/a	2.3	1.7	199	57.0	36
48.0	11,000	4.8	3.9	27.8	n/a	34.8	n/a	2.8	2.0	209	75.0	48

Notes: 1. Coil resistance not directly measurable. Coil current should be within limits shown when tested at nominal voltage at 25°C for 5 seconds max.  
 2. Set base current at 3 mA to 15 mA during measurements.

Ordering Instructions

Catalog-selected Relays: The catalog number is derived by choosing the proper CODE for each of the relay characteristics in the order in which the codes are listed.

Specifying a Part Number Example:

Type	Terminal	Diodes	Ground Pins	Coils	Spreader/Mounting Pads
MS	C	D	G	-26	S

\* The part number example shown on this page is for catalog items. For a list of specific QPL part numbers, please see the index in Section 15.

**Double Pole, Electrically Held, 1 Amp and Less** (Continued)

HM, HMD, HS, HSD



**HM, HS**  
Standard / Sensitive TO-5  
Commercial Relay

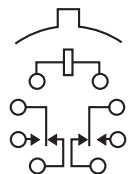

Terminal View

**Product Facts**

- Hermetically sealed
- Spreader Pads
- Excellent RF switching

**Electrical Characteristics**

**Contact Arrangement** — 2 Form C (DPDT)  
**Contact Material** — Stationary — Gold/platinum/palladium/silver alloy (gold plated)  
 Moveable — Gold/platinum/palladium/silver alloy (gold plated)  
**Contact Resistance** — Before Life — 100 milliohms max. (measured @ 10 mA @ 6 Vdc)  
 After Life — 200 milliohms max. (measured @ 1 A @ 28 Vdc)  
**Mechanical Life Expectancy** — 1 million operations

**HMD, HSD**  
Standard / Sensitive TO-5  
Diode Suppressed  
Commercial Relay

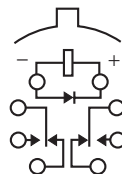

Terminal View

**Product Facts**

- Suppression Diode
- Hermetically sealed
- Spreader Pads
- Excellent RF switching

**Electrical Characteristics**

**Coil Voltage** — 5 to 30 Vdc (HM/HMD)  
 5 to 48 Vdc (HS/HSD)  
**Coil Power** — HM/HMD — 675 mW max. @ 25°C  
 HS/HSD — 565 mW max. @ 25°C  
**Duty Cycle** — Continuous  
**Pick-up Voltage** — Approximately 70% of nominal coil voltage  
**Pick-up Sensitivity** — HM/HMD — 180 mW max. @ 25°C  
 HS/HSD — 90 mW max. @ 25°C

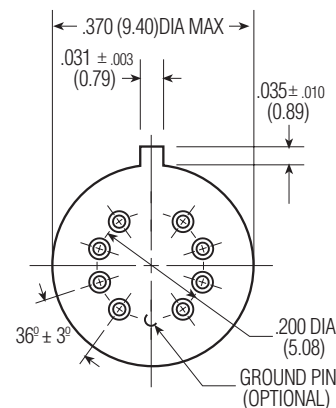

Header

**Contact Ratings**

Contact Load	Type	Operations Min.
1.0 A @ 28 Vdc	Resistive	100,000
250 mA @ 115 Vac, 60 Hz & 400 Hz	Resistive (Case not grounded)	100,000
100 mA @ 115 Vac, 60 Hz & 400 Hz	Resistive	100,000
0.2 A @ 28 Vdc	Inductive (0.32 Henry)	100,000
0.1 A @ 28 Vdc	Lamp	100,000
30 μA @ 50 mVdc	Low Level	1,000,000

**Double Pole, Electrically Held, 1 Amp and Less** (Continued)

**HM, HMD, HS, HSD**

(Continued)

**Operating Characteristics**

**Timing** —

- Operate Time —
- HM/HMD — 4.0 ms max.
- HS/HSD — 6.0 ms max.
- Release Time —
- HM — 3.0 ms max.
- HS — 3.0 ms max.
- HMD — 6.0 ms max.
- (suppression diode)
- HSD — 7.5 ms max.
- (suppression diode)

**Dielectric Withstanding Voltage** —

- Between Open Contacts —
- 350 Vrms 60 Hz
- Between Adjacent Contacts —
- 350 Vrms 60 Hz
- Between Contacts & Coil —
- 350 Vrms 60 Hz

**Insulation Resistance** —

1,000 megohms @ 500 Vdc

**Environmental Characteristics**

**Temperature Range** —

-55°C to +85°C

**Weight** —

- HM/HMD —
- 0.09 oz. (2.55 gms)
- 0.099 oz. (2.80 gms) w/ spreader pad
- HS/HSD —
- 0.12 oz. (3.40 gms)
- 0.129 oz. (3.45 gms) w/ spreader pad

**Vibration Resistance** —

10 G's, 10 to 500 Hz

**Shock Resistance** —

30 G's, 6 ±1 ms

**Semiconductor Characteristics**

**Diode** —

- 100 Vdc peak inverse voltage (PIV)
- 1.0 Vdc max. transient voltage

**Standard Coil Data**

	Nom. Coil Voltage (Vdc)	Coil Resistance in Ohms ±20% @ 25°C	Pickup Voltage Vdc (max.) @ 25°C	Nom. Coil Power (mW) @ 25°C	Max. Coil Voltage	Coil Desig.
HM/HMD	5.0	50	3.6	500	5.8	5
	6.0	98	4.2	367	8.0	6
	9.0	220	6.5	368	12.0	9
	12.0	390	8.4	369	16.0	12
	18.0	880	13.0	368	24.0	18
HS/HSD	26.5	1,560	17.0	450	32.0	26
	30.0	2,500	22.0	360	36.0	30
	5.0	100	3.5	250	7.5	5
	6.0	200	4.5	180	10.0	6
	9.0	400	6.8	203	15.0	9
	12.0	850	9.0	169	20.0	12
	18.0	1,600	13.5	203	30.0	18
	26.5	3,300	18.0	213	40.0	26
	36.0	6,500	24.0	199	57.0	36
	48.0	11,000	32.0	209	75.0	48

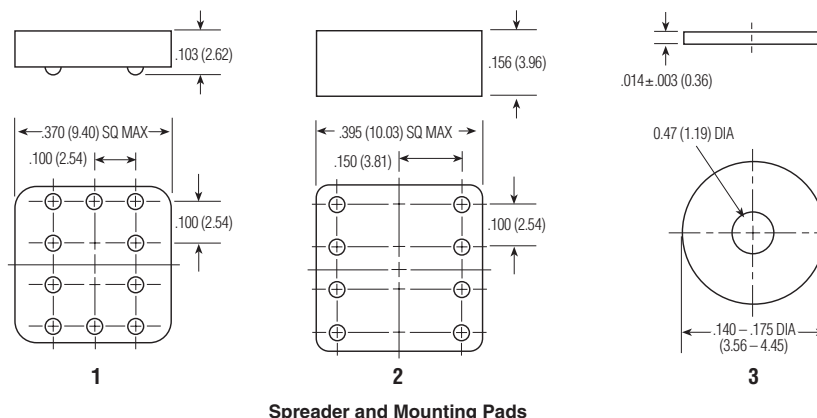
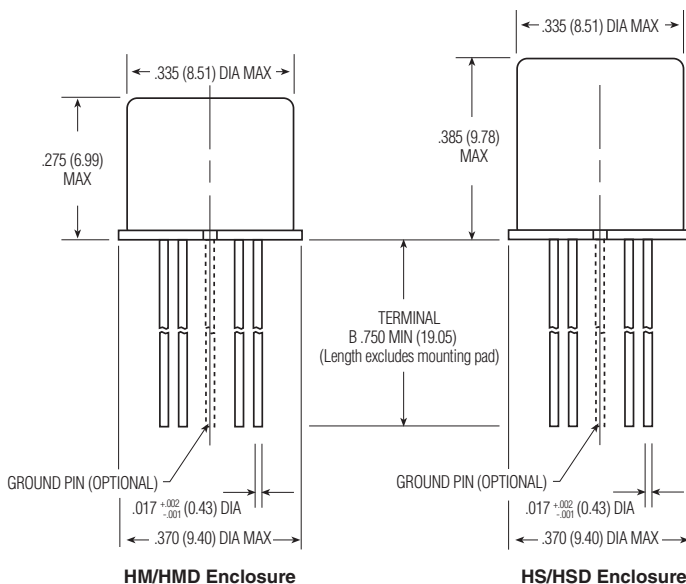

**Ordering Instructions**

Catalog-selected Relays: The catalog number is derived by choosing the proper CODE for each of the relay characteristics in the order in which the codes are listed.

**Specifying a Part Number Example:**

Type	Diodes	Ground Pin	Spreader/Mounting Pads	Coils	Terminals
HM	D	X	3	-26	B

Double Pole, Electrically Held, 1 Amp and Less (Continued)

MGA, MGAD, MGADD

**MGA**  
Standard .100 Grid  
High Performance Relay  
Qualified to  
MIL-R-39016/17

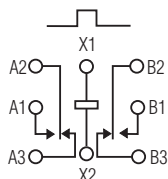

Terminal View

**MGAD**  
Standard .100 Grid  
Diode Suppressed  
High Performance Relay  
Qualified to  
MIL-R-39016/18

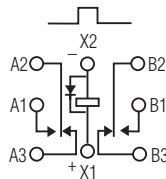

Terminal View

**MGADD**  
Standard .100 Grid Diode  
Suppressed/Protected  
High Performance Relay  
Qualified to  
MIL-R-39016/19

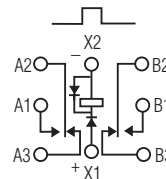

Terminal View

Product Facts

- Hermetically sealed
- High shock & vibration ratings
- Mounting pads
- Excellent RF switching

Product Facts

- Suppression diode
- Hermetically sealed
- High shock & vibration ratings
- Mounting pads
- Excellent RF switching

Product Facts

- Suppression & protection diodes
- Hermetically sealed
- High shock & vibration ratings
- Mounting pads
- Excellent RF switching

Electrical Characteristics

**Contact Arrangement** — 2 Form C (DPDT)

**Contact Material** — Stationary — Gold/platinum/palladium/silver (gold plated)  
Moveable — Gold/platinum/palladium/silver (gold plated)

**Contact Resistance** — Before Life — 100 milliohms max. (measured @ 10 mA @ 6 Vdc)  
After Life — 200 milliohms max. (measured @ 1 A @ 28 Vdc)

**Mechanical Life Expectancy** — 1 million operations

**Coil Voltage** — 5 to 26.5 Vdc

**Coil Power** — 660 mW max. @ 25°C

**Duty Cycle** — Continuous

**Pick-up Voltage** — Approximately 50% of nominal coil voltage

**Pick-up Sensitivity** — 130 mW max. @ 25°C

Contact Ratings

Contact Load	Type	Operations Min.
1.0 A @ 28 Vdc	Resistive	100,000
250 mA @ 115 Vac, 60 Hz & 400 Hz	Resistive (case not grounded)	100,000
100 mA @ 115 Vac, 60 Hz & 400 Hz	Resistive	100,000
0.2 A @ 28 Vdc	Inductive (0.32 Henry)	100,000
0.1 A @ 28 Vdc	Lamp	100,000
30 μA @ 50 mVdc	Low Level	1,000,000
0.1 A @ 28 Vdc	Intermediate Current	50,000



MGA

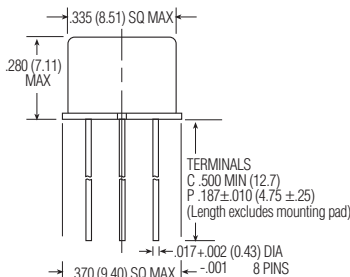

MGA/MGAD/MGADD Enclosure

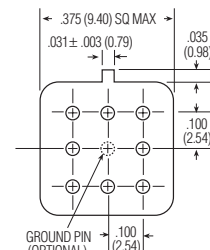

MGA/MGAD/MGADD Header

**Double Pole, Electrically Held, 1 Amp and Less** (Continued)

**MGA, MGAD, MGADD**

(Continued)

**Operating Characteristics**

**Timing** —  
Operate Time — 2.0 ms max.  
Release Time —  
MGA — 1.5 ms max.  
MGAD/MGADD — 4.0 ms max.  
(suppression diode, protection/  
suppression diodes)  
**Contact Bounce** — 1.5 ms max.  
**Dielectric Withstanding Voltage**  
— Between Open Contacts —  
500 Vrms 60 Hz  
Between Adjacent Contacts —  
500 Vrms 60 Hz  
Between Contacts & Coil —  
500 Vrms 60 Hz  
**Insulation Resistance** —  
10,000 megohms min. @ 500 Vdc  
1,000 megohms @ 500 Vdc  
(coil to case @ +125°C)

**Environmental Characteristics**

**Temperature Range** —  
-65°C to +125°C  
**Weight** —  
0.09 oz. (2.55 gms)  
0.129 oz. (3.45 gms) w/ mounting pad  
attached  
**Vibration Resistance** —  
30 G's, 10 to 3,000 Hz  
**Shock Resistance** —  
75 G's, 6 ±1 ms max.  
**QPL Approval** —  
MIL-R-39016/17 (JMGA)  
MIL-R-39016/18 (JMGAD)  
MIL-R-39016/19 (JMGADD)

**Semiconductor Characteristics**

**Diode** —  
100 Vdc peak inverse voltage (PIV)  
1.0 Vdc max. transient voltage

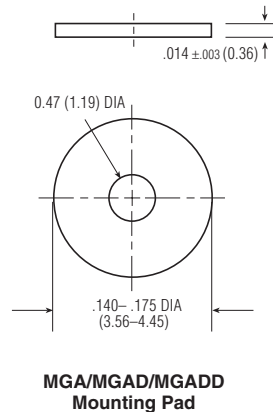

**Coil Data**

Nom. Coil Voltage (Vdc)	Coil Resistance in Ohms ±10% @ 25°C (Note)	Coil Circuit Current mA (Max.) (Note)	Coil Circuit Current mA (Min.) (Note)	Pickup Voltage Vdc (Max.) @ 25°C	Pickup Voltage Vdc (Max.) @ 125°C	Drop-Out Voltage Vdc (Min.) @ 25°C	Drop-Out Voltage Vdc (Min.) @ -65°C	Nom. Coil Power (mW) @ 25°C	Max. Coil Voltage	Coil Desig.
<b>MGAD/MGAD</b>										
5.0	50	n/a	n/a	2.7	3.5	0.22	0.14	500	5.8	5
6.0	98	n/a	n/a	3.5	4.5	0.28	0.18	367	8.0	6
9.0	220	n/a	n/a	5.3	6.8	0.54	0.35	368	12.0	9
12.0	390	n/a	n/a	7.0	9.0	0.63	0.41	369	16.0	12
18.0	880	n/a	n/a	10.5	13.5	0.91	0.59	368	24.0	18
26.5	1,560	n/a	n/a	14.2	18.0	1.37	0.89	450	32.0	26
<b>MGADD</b>										
5.0	39	128.2	93.2	3.2	4.0	0.6	0.6	641	5.8	5
6.0	78	78.3	58.3	4.0	5.0	0.7	0.7	462	8.0	6
9.0	220	42.9	33.0	6.3	7.8	0.9	0.8	368	12.0	9
12.0	390	32.8	25.6	8.0	10.0	1.1	0.9	369	16.0	12
18.0	880	22.1	17.5	11.5	14.5	1.4	1.1	368	24.0	18
26.5	1,560	18.5	14.8	15.2	19.0	1.8	1.4	450	32.0	26

**Note:** Coil resistance not directly measurable. Coil current should be within limits shown when tested at nominal voltage at 25°C for 5 seconds max.

**Ordering Instructions**

Catalog-selected Relays: The catalog number is derived by choosing the proper CODE for each of the relay characteristics in the order in which the codes are listed.

**Specifying a Part Number Example:**

<b>Type</b>	<b>Terminals</b>	<b>Diodes</b>	<b>Ground Pins</b>	<b>Coils</b>	<b>Mounting Pads</b>
MGA	C	D	G	-26	W

\* The part number example shown on this page is for catalog items. For a list of specific QPL part numbers, please see the index in Section 15.

Double Pole, Electrically Held, 1 Amp and Less (Continued)

MGS, MGSD, MGSDD

**MGS**  
Sensitive .100 Grid  
High Performance Relay  
Qualified to  
MIL-R-39016/41

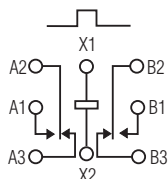

Terminal View

**MGSD**  
Sensitive .100 Grid  
Diode Suppressed  
High Performance Relay  
Qualified to  
MIL-R-39016/42

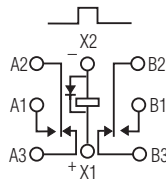

Terminal View

**MGSDD**  
Sensitive .100 Grid Diode  
Suppressed/Protected  
High Performance Relay  
Qualified to  
MIL-R-39016/43

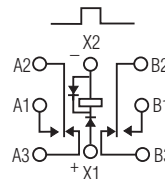

Terminal View

Product Facts

- Hermetically sealed
- High shock & vibration ratings
- Mounting pads
- Excellent RF switching

Product Facts

- Suppression diode
- Hermetically sealed
- High shock & vibration ratings
- Mounting pads
- Excellent RF switching

Product Facts

- Suppression & protection diodes
- Hermetically sealed
- High shock & vibration ratings
- Mounting pads
- Excellent RF switching

Electrical Characteristics

**Contact Arrangement** — 2 Form C (DPDT)

**Contact Material** — Stationary — Gold/platinum/palladium/silver (gold plated)  
Moveable — Gold/platinum/palladium/silver (gold plated)

**Contact Resistance** — Before Life — 100 milliohms max. (measured @ 10 mA @ 6 Vdc)  
After Life — 200 milliohms max. (measured @ 1 A @ 28 Vdc)

**Mechanical Life Expectancy** — 1 million operations

**Coil Voltage** — 5 to 48 Vdc  
**Coil Power** — 565 mW max. @ 25°C

**Duty Cycle** — Continuous

**Pick-up Voltage** — Approximately 50% of nominal coil voltage

**Pick-up Sensitivity** — 60 mW max. @ 25°C

Contact Ratings

Contact Load	Type	Operations Min.
1.0 A @ 28 Vdc	Resistive	100,000
250 mA @ 115 Vac, 60 Hz & 400 Hz	Resistive (case not grounded)	100,000
100 mA @ 115 Vac, 60 Hz & 400 Hz	Resistive	100,000
0.2 A @ 28 Vdc	Inductive (0.32 Henry)	100,000
0.1 A @ 28 Vdc	Lamp	100,000
30 μA @ 50 mVdc	Low Level	1,000,000
0.1 A @ 28 Vdc	Intermediate Current	50,000



MGS

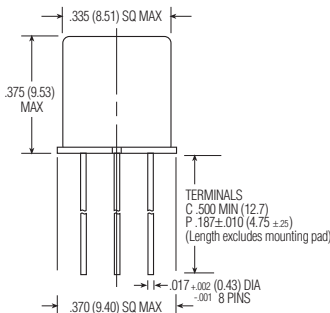

MGS/MGSD/MGSDD Enclosure

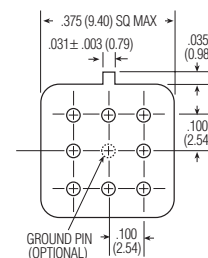

MGS/MGSD/MGSDD Header

**Double Pole, Electrically Held, 1 Amp and Less** (Continued)

**MGS, MGSD, MGSDD**  
(Continued)

**Operating Characteristics**

**Timing** —  
Operate Time — 4.0 ms max.  
Release Time —  
MGS — 2.0 ms max.  
MGSD/MGSDD — 7.5 ms max.  
(suppression diode, protection/  
suppression diodes)  
**Contact Bounce** — 1.5 ms max.  
**Dielectric Withstanding Voltage**  
— Between Open Contacts —  
500 Vrms 60 Hz  
Between Adjacent Contacts —  
500 Vrms 60 Hz  
Between Contacts & Coil —  
500 Vrms 60 Hz  
**Insulation Resistance** —  
10,000 megohms min. @ 500 Vdc  
1,000 megohms @ 500 Vdc  
(coil to case @ +125°C)

**Environmental Characteristics**

**Temperature Range** —  
-65°C to +125°C  
**Weight** —  
0.09 oz. (2.55 gms)  
0.129 oz. (3.45 gms) w/ mounting pad  
attached  
**Vibration Resistance** —  
30 G's, 10 to 3,000 Hz  
**Shock Resistance** —  
75 G's, 6 ±1 ms max.  
**QPL Approval** —  
MIL-R-39016/41 (JMGS)  
MIL-R-39016/42 (JMGSDD)  
MIL-R-39016/43 (JMGSDD)

**Semiconductor Characteristics**

**Diode** —  
100 Vdc peak inverse voltage (PIV)  
1.0 Vdc max. transient voltage

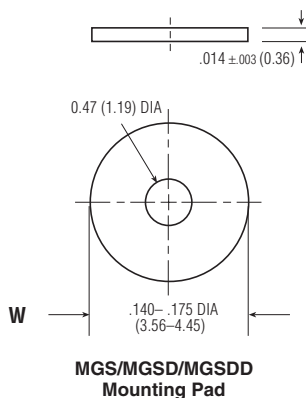

**Coil Data**

Nom. Coil Voltage (Vdc)	Coil Resistance in Ohms ±10% @ 25°C (Note)	Coil Circuit Current mA (Max.) (Note)	Coil Circuit Current mA (Min.) (Note)	Pickup Voltage Vdc (Max.) @ 25°C	Pickup Voltage Vdc (Max.) @ 125°C	Drop-Out Voltage Vdc (Min.) @ 25°C	Drop-Out Voltage Vdc (Min.) @ -65°C	Nom. Coil Power (mW) @ 25°C	Max. Coil Voltage	Coil Desig.
<b>MGS/MGSD</b>										
5.0	100	n/a	n/a	2.6	3.5	0.23	0.12	250	7.5	5
6.0	200	n/a	n/a	3.4	4.5	0.28	0.18	180	10.0	6
9.0	400	n/a	n/a	4.85	6.8	0.55	0.35	203	15.0	9
12.0	800	n/a	n/a	7.0	9.0	0.64	0.41	180	20.0	12
18.0	1,600	n/a	n/a	9.8	13.5	0.92	0.59	203	30.0	18
26.5	3,200	n/a	n/a	14.0	18.0	1.4	0.89	219	40.0	26
36.0	6,500	n/a	n/a	20.0	27.0	1.8	1.25	199	57.0	36
48.0	11,000	n/a	n/a	25.8	36.0	2.4	1.60	209	75.0	48
<b>MGSDD</b>										
5.0	64	78.1	56.8	2.9	3.7	0.8	0.7	391	7.5	5
6.0	125	48.9	36.3	4.0	4.8	0.9	0.8	288	10.0	6
9.0	400	23.6	18.1	6.1	8.0	1.1	0.9	203	15.0	9
12.0	800	16.0	12.5	7.8	11.0	1.3	1.0	180	20.0	12
18.0	1,600	12.2	9.6	11.3	14.5	1.5	1.1	203	30.0	18
26.5	3,200	9.0	7.2	15.2	19.0	1.7	1.3	219	40.0	26
36.0	6,500	6.1	4.9	21.7	27.2	2.3	1.7	199	57.0	36
48.0	11,000	4.8	3.9	27.8	34.8	2.8	2.0	209	75.0	48

**Note:** Coil resistance not directly measurable. Coil current should be within limits shown when tested at nominal voltage at 25°C for 5 seconds max.

**Ordering Instructions**

Catalog-selected Relays: The catalog number is derived by choosing the proper CODE for each of the relay characteristics in the order in which the codes are listed.

**Specifying a Part Number Example:**

<b>Type</b>	<b>Terminals</b>	<b>Diodes</b>	<b>Ground Pins</b>	<b>Coils</b>	<b>Mounting Pads</b>
MGS	C	D	G	-26	W

\* The part number example shown on this page is for catalog items. For a list of specific QPL part numbers, please see the index in Section 15.

**Double Pole, Electrically Held, 1 Amp and Less** (Continued)

HC, HCD, HCS, HCSD



**HC, HCS**

**Standard / Sensitive  
.100 Grid Commercial Relay**

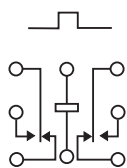

Terminal View

**HCD, HCSD**

**Standard / Sensitive  
.100 Grid Diode Suppressed  
Commercial Relay**

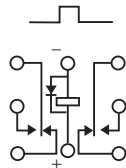

Terminal View

**Product Facts**

- Hermetically sealed
- Mounting pads
- Excellent RF switching

**Product Facts**

- Suppression diode
- Hermetically sealed
- Mounting pads
- Excellent RF switching

**Electrical Characteristics**

**Contact Arrangement** —  
2 Form C (DPDT)

**Contact Material** —  
Stationary —  
Gold/platinum/palladium/silver alloy  
(gold plated)  
Moveable —  
Gold/platinum/palladium/silver alloy  
(gold plated)

**Contact Resistance** —  
Before Life — 100 milliohms max.  
(measured @ 10 mA @ 6 Vdc)  
After Life — 200 milliohms max.  
(measured @ 1 A @ 28 Vdc)

**Mechanical Life Expectancy** —  
1 million operations

**Coil Voltage** —  
5 to 26.5 Vdc (HC/HCD)  
5 to 48 Vdc (HCS/HCSD)

**Coil Power** —  
HC/HCD — 660 mW max. @ 25°C  
HCS/HCSD — 565 mW max. @ 25°C

**Duty Cycle** — Continuous

**Pick-up Voltage** — Approximately  
70% of nominal coil voltage

**Pick-up Sensitivity** —  
HC/HCD — 180 mW max. @ 25°C  
HCS/HCSD — 90 mW max. @ 25°C

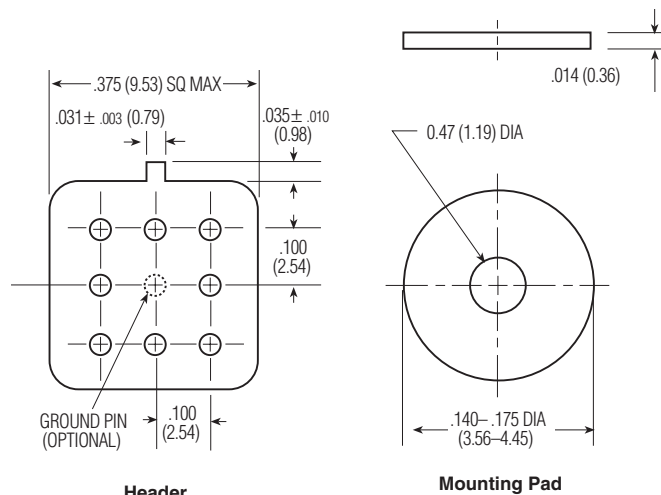

**Contact Ratings**

Contact Load	Type	Operations Min.
1.0 A @ 28 Vdc	Resistive	100,000
250 mA @ 115 Vac, 60 Hz & 400 Hz	Resistive (Case not grounded)	100,000
100 mA @ 115 Vac, 60 Hz & 400 Hz	Resistive	100,000
0.2 A @ 28 Vdc	Inductive (0.32 Henry)	100,000
0.1 A @ 28 Vdc	Lamp	100,000
30 μA @ 50 mVdc	Low Level	1,000,000

**Double Pole, Electrically Held, 1 Amp and Less** (Continued)

**HC, HCD, HCS, HCSD**

(Continued)

**Operating Characteristics**

**Timing** —

- Operate Time —
- HC/HCD — 4.0 ms max.
- HCS/HCSD — 6.0 ms max.
- Release Time —
- HC — 3.0 ms max.
- HCS — 3.0 ms max.
- HCD — 6.0 ms max.
- (suppression diode)
- HCSD — 7.5 ms max.
- (suppression diode)

**Dielectric Withstanding Voltage** —

- Between Open Contacts —
- 350 Vrms 60 Hz
- Between Adjacent Contacts —
- 350 Vrms 60 Hz
- Between Contacts & Coil —
- 350 Vrms 60 Hz

**Insulation Resistance** —

1,000 megohms @ 500 Vdc

**Environmental Characteristics**

**Temperature Range** —

-55°C to +85°C

**Weight** —

- HC/HCD —
- 0.09 oz. (2.55 gms)
- HCS/HCSD —
- 0.15 oz. (4.30 gms)

**Vibration Resistance** —

10 G's, 10 to 500 Hz

**Shock Resistance** —

30 G's, 6 ±1 ms

**Semiconductor Characteristics**

**Diode** —

- 100 Vdc peak inverse voltage (PIV)
- 1.0 Vdc max. transient voltage

**Standard Coil Data**

	Nom. Coil Voltage (Vdc)	Coil Resistance in Ohms ±20% @ 25°C	Pickup Voltage Vdc (Max.) @ 25°C	Nom. Coil Power (mW) @ 25°C	Max. Coil Voltage	Coil Desig.
HC/HCD	5.0	64	3.8	391	5.8	5
	6.0	98	4.9	367	8.0	6
	9.0	220	7.0	368	12.0	9
	12.0	400	9.0	360	16.0	12
	18.0	880	14.0	368	24.0	18
	26.5	1,600	18.0	439	32.0	26
HCS/HCSD	5.0	100	3.5	250	7.5	5
	6.0	200	4.5	180	10.0	6
	9.0	400	6.8	203	15.0	9
	12.0	800	9.0	180	20.0	12
	18.0	1,600	13.5	203	30.0	18
	26.5	3,200	18.0	219	40.0	26
	36.0	6,500	24.0	199	57.0	36
	48.0	11,000	32.0	209	75.0	48

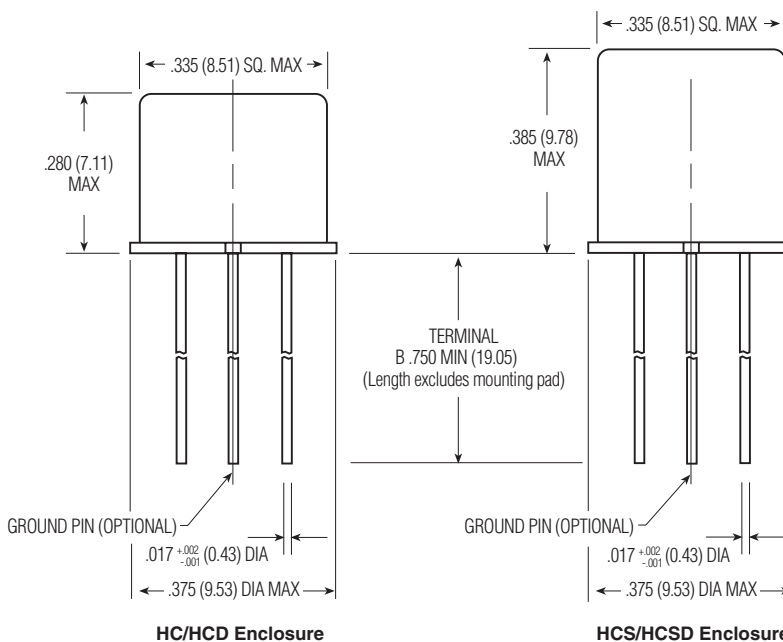

**Ordering Instructions**

Catalog-selected Relays: The catalog number is derived by choosing the proper CODE for each of the relay characteristics in the order in which the codes are listed.

**Specifying a Part Number Example:**

Type	Diodes	Ground Pin	Mounting Pads	Coils	Terminals
HC	D	X	3	-26	B

Double Pole, Electrically Held, 1 Amp and Less (Continued)

MAT

**MAT**  
**Standard TO-5**  
**Diode Suppressed/**  
**Transistor Driven**  
**High Performance Relay**  
**Qualified to MIL-R-28776/1**

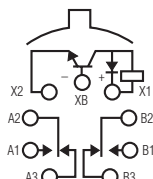

Terminal View

**Product Facts**

- Transistor driver & suppression diode
- Hermetically sealed
- High shock & vibration ratings
- Spreader pads
- Excellent RF switching

**Electrical Characteristics**

**Contact Arrangement** — 2 Form C (DPDT)

**Contact Material** — Stationary — Gold/platinum/palladium/silver alloy (gold plated)  
 Moveable — Gold/platinum/palladium/silver alloy (gold plated)

**Contact Resistance** — Before Life — 100 milliohms max. (measured @ 10 mA @ 6 Vdc)  
 After Life — 200 milliohms max. (measured @ 1 A @ 28 Vdc)

**Mechanical Life Expectancy** — 1 million operations

**Coil Voltage** — 5 to 26.5 Vdc  
**Coil Power** — 675 mW max. @ 25°C

**Duty Cycle** — Continuous  
**Pick-up Voltage** — Approximately 50% of nominal coil voltage  
**Pick-up Sensitivity** — 130 mW max. @ 25°C

**Contact Ratings**

Contact Load	Type	Operations Min.
1.0 A @ 28 Vdc	Resistive	100,000
250 mA @ 115 Vac, 60 Hz & 400 Hz	Resistive (case not grounded)	100,000
100 mA @ 115 Vac, 60 Hz & 400 Hz	Resistive	100,000
0.2 A @ 28 Vdc	Inductive (0.32 Henry)	100,000
0.1 A @ 28 Vdc	Lamp	100,000
30 µA @ 50 mVdc	Low Level	1,000,000
0.1 A @ 28 Vdc	Intermediate Current	50,000

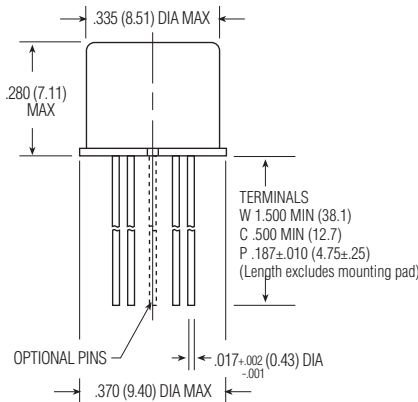

Enclosure

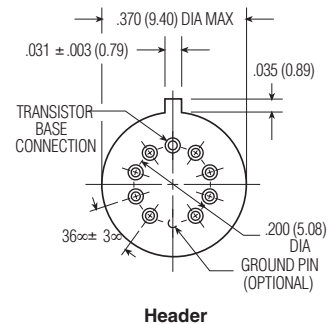

Header

**Double Pole, Electrically Held, 1 Amp and Less** (Continued)

MAT (Continued)

**Operating Characteristics**

**Timing** —  
Operate Time — 2.0 ms max.  
Release Time — 7.5 ms max.  
**Contact Bounce** — 1.5 ms max  
**Dielectric Withstanding Voltage** —  
Between Open Contacts —  
500 Vrms 60 Hz  
Between Adjacent Contacts —  
500 Vrms 60 Hz  
Between Contacts & Coil —  
500 Vrms 60 Hz  
**Insulation Resistance** —  
10,000 megohms @ 500 Vdc  
1,000 megohms @ 500 Vdc  
(coil to case @ +125°C)

**Environmental Characteristics**

**Temperature Range** —  
-65°C to +125°C  
**Weight** —  
0.09 oz. (2.55 grms)  
0.10 oz. (2.80 grms) with spreader pad attached  
**Vibration Resistance** —  
30 G's, 10 to 3,000 Hz  
**Shock Resistance** —  
75 G's, 6 ±1 ms max.  
**QPL Approval** —  
MIL-R-28776/1 (JMAT)

**Semiconductor Characteristics**

**Diode** —  
100 Vdc peak inverse voltage (PIV)  
1.0 Vdc max. transient voltage  
**Transistor** —  
0.3 Vdc min. base turn off voltage;  
6.0 Vdc min. emitter-base breakdown voltage (BV<sub>EBO</sub>) @ 25°C;  
80.0 Vdc min. collector-base breakdown voltage (BV<sub>CBO</sub>) @ 25°C & I<sub>C</sub>=100 µA

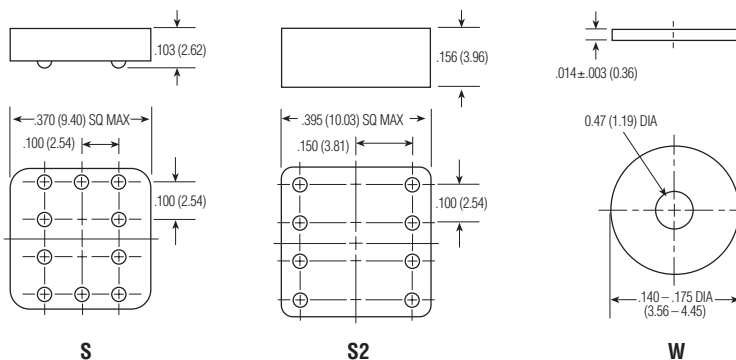

Spreader & Mounting Pads

**Coil Data**

Nom. Coil Voltage (Vdc)	Coil Resistance in Ohms ±10% @ 25°C (Note 1)	Coil Circuit Current mA (Max.) (Note 1&2)	Coil Circuit Current mA (Min.) (Note 1&2)	Pickup Voltage Vdc (Max.) @ 25°C (Note 2)	Base Turn On Current mA (Max.) @ 25°C	Pickup Voltage Vdc (Max.) @ 125°C (Note 2)	Base Turn On Current mA (Max.) @ 125°C	Drop-Out Voltage Vdc (Min.) @ 25°C (Note 2)	Drop-Out Voltage Vdc (Min.) @ -65°C (Note 2)	Nom. Coil Power (mW) @ 25°C	Max. Coil Voltage	Coil Desig.
MAT												
5.0	50	112.1	82.2	2.7	0.75	3.5	3.00	0.22	0.14	500	5.8	5
6.0	98	69.9	52.9	3.5	0.55	4.5	2.04	0.28	0.18	367	8.0	6
9.0	220	47.4	35.3	5.3	0.36	6.8	1.36	0.54	0.35	368	12.0	9
12.0	390	35.8	26.6	7.0	0.27	9.0	1.03	0.63	0.41	369	16.0	12
18.0	880	24.0	17.9	10.5	0.16	13.5	0.68	0.91	0.59	368	24.0	18
26.5	1,560	19.8	14.7	14.2	0.13	18.0	0.50	1.37	0.89	450	32.0	26

**Notes:** 1. Coil resistance not directly measurable. Coil current should be within limits shown when tested at nominal voltage at 25°C for 5 seconds max.  
2. Set base current at 3 mA to 15 mA during measurements.

**Ordering Instructions**

Catalog-selected Relays: The catalog number is derived by choosing the proper CODE for each of the relay characteristics in the order in which the codes are listed.

**Specifying a Part Number Example:**

<u>Type</u>	<u>Terminal</u>	<u>Diodes</u>	<u>Ground Pins</u>	<u>Coils</u>	<u>Spreader/Mounting Pads</u>
MA	C	T	G	-26	S

\* The part number example shown on this page is for catalog items. For a list of specific QPL part numbers, please see the index in Section 15.

Double Pole, Electrically Held, 1 Amp and Less (Continued)

MST

**MST**  
**Sensitive T0-5**  
**Diode Suppressed/**  
**Transistor Driven**  
**High Performance Relay**  
**Qualified to MIL-R-28776/3**

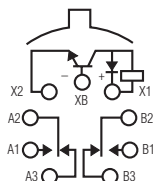

Terminal View

**Product Facts**

- Transistor driver & suppression diode
- Hermetically sealed
- High shock & vibration ratings
- Spreader pads
- Excellent RF switching

**Electrical Characteristics**

**Contact Arrangement** — 2 Form C (DPDT)

**Contact Material** — Stationary — Gold/platinum/palladium/silver alloy (gold plated)  
 Moveable — Gold/platinum/palladium/silver alloy (gold plated)

**Contact Resistance** — Before Life — 100 milliohms max. (measured @ 10 mA @ 6 Vdc)  
 After Life — 200 milliohms max. (measured @ 1 A @ 28 Vdc)

**Mechanical Life Expectancy** — 1 million operations

**Coil Voltage** — 5 to 48 Vdc  
**Coil Power** — 565 mW max. @ 25°C  
**Duty Cycle** — Continuous  
**Pick-up Voltage** — Approximately 50% of nominal coil voltage  
**Pick-up Sensitivity** — 60 mW max. @ 25°C

**Contact Ratings**

Contact Load	Type	Operations Min.
1.0 A @ 28 Vdc	Resistive	100,000
250 mA @ 115 Vac, 60 Hz & 400 Hz	Resistive (case not grounded)	100,000
100 mA @ 115 Vac, 60 Hz & 400 Hz	Resistive	100,000
0.2 A @ 28 Vdc	Inductive (0.32 Henry)	100,000
0.1 A @ 28 Vdc	Lamp	100,000
30 µA @ 50 mVdc	Low Level	1,000,000
0.1 A @ 28 Vdc	Intermediate Current	50,000

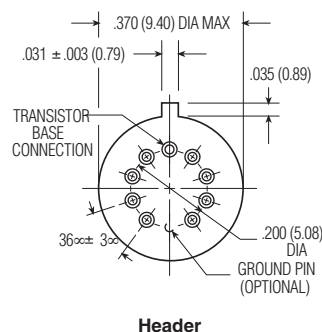
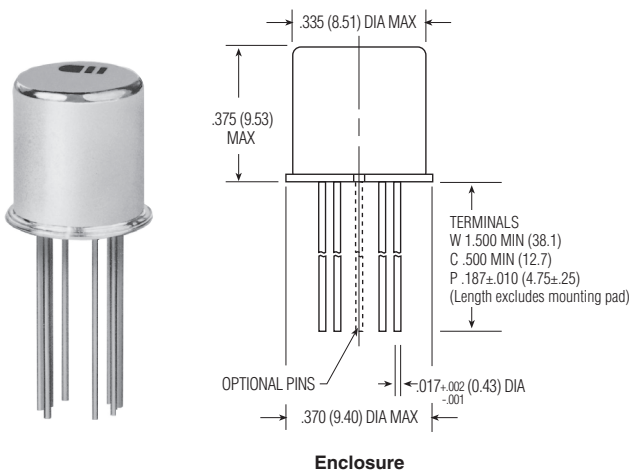

Double Pole, Electrically Held, 1 Amp and Less (Continued)

MST (Continued)

Operating Characteristics

**Timing** —  
 Operate Time — 4.0 ms max.  
 Release Time — 7.5 ms max.  
**Contact Bounce** — 1.5 ms max  
**Dielectric Withstanding Voltage** —  
 Between Open Contacts —  
 500 Vrms 60 Hz  
 Between Adjacent Contacts —  
 500 Vrms 60 Hz  
 Between Contacts & Coil —  
 500 Vrms 60 Hz  
**Insulation Resistance** —  
 10,000 megohms min. @ 500 Vdc  
 1,000 megohms @ 500 Vdc  
 (coil to case @ +125°C)

Environmental Characteristics

**Temperature Range** —  
 -65°C to +125°C  
**Weight** —  
 0.12 oz. (3.40 grms)  
 0.13 oz. (3.45 grms) with spreader pad  
 attached  
**Vibration Resistance** —  
 30 G's, 10 to 3,000 Hz  
**Shock Resistance** —  
 75 G's, 6 ±1 ms max.  
**QPL Approval** —  
 MIL-R-28776/3 (JMST)

Semiconductor Characteristics

**Diode** —  
 100 Vdc peak inverse voltage (PIV)  
 1.0 Vdc max. transient voltage  
**Transistor** —  
 0.3 Vdc min. base turn off voltage;  
 6.0 Vdc min. emitter-base breakdown  
 voltage (BV<sub>EBO</sub>) @ 25°C;  
 80.0 Vdc min. collector-base breakdown  
 voltage (BV<sub>CBO</sub>) @ 25°C & I<sub>C</sub>=100 µA

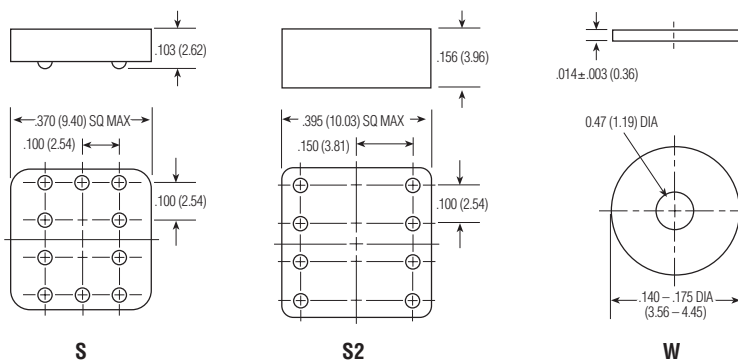

Spreader & Mounting Pads

Coil Data

Nom. Coil Voltage (Vdc)	Coil Resistance in Ohms ±10% @ 25°C (Note 1)	Coil Circuit Current mA (Max.) (Note 1&2)	Coil Circuit Current mA (Min.) (Note 1&2)	Pickup Voltage Vdc (Max.) @ 25°C (Note 2)	Base Turn On Current mA (Max.) @ 25°C	Pickup Voltage Vdc (Max.) @ 125°C (Note 2)	Base Turn On Current mA (Max.) @ 125°C	Drop-Out Voltage Vdc (Min.) @ 25°C (Note 2)	Drop-Out Voltage Vdc (Min.) @ -65°C (Note 2)	Nom. Coil Power (mW) @ 25°C	Max. Coil Voltage	Coil Desig.
MST												
5.0	100	59.3	43.5	2.8	0.37	3.6	1.50	0.22	0.14	250	7.0	5
6.0	200	35.4	26.4	3.8	0.25	4.8	1.00	0.28	0.18	180	10.0	6
9.0	400	25.8	19.7	5.2	0.18	7.8	0.75	0.54	0.35	203	15.0	9
12.0	850	16.7	12.2	7.4	0.12	11.0	0.47	0.63	0.41	169	20.0	12
18.0	1,600	13.1	9.7	10.0	0.09	14.5	0.38	0.91	0.59	203	30.0	18
26.5	3,300	9.5	6.9	14.2	0.06	19.0	0.24	1.37	0.89	213	40.0	26
36.0	6,500	6.4	4.8	20.0	0.034	27.0	0.17	1.80	1.25	199	57.0	36
48.0	11,000	5.1	3.7	25.8	0.026	36.0	0.13	2.40	1.60	209	75.0	48

Notes: 1. Coil resistance not directly measurable. Coil current should be within limits shown when tested at nominal voltage at 25°C for 5 seconds max.  
 2. Set base current at 3 mA to 15 mA during measurements.

Ordering Instructions

Catalog-selected Relays: The catalog number is derived by choosing the proper CODE for each of the relay characteristics in the order in which the codes are listed.

Specifying a Part Number Example:

<b>Type</b>	<b>Terminal</b>	<b>Diodes</b>	<b>Ground Pins</b>	<b>Coils</b>	<b>Spreader/Mounting Pads</b>
MS	C	T	G	-26	S

\* The part number example shown on this page is for catalog items. For a list of specific QPL part numbers, please see the index in Section 15.

Double Pole, Electrically Held, 1 Amp and Less (Continued)

MGAT

MGAT

Standard .100 Grid Diode Suppressed/MOSFET Driven High Performance Relay

Qualified to MIL-R-28776/6

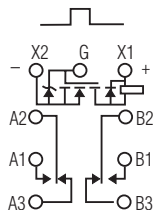

Terminal View

Product Facts

- MOSFET driver, zener & suppression diodes
- Hermetically sealed
- High shock & vibration ratings
- Mounting pads
- Excellent RF switching

Electrical Characteristics

**Contact Arrangement** — 2 Form C (DPDT)

**Contact Material** — Stationary — Gold/platinum/palladium/silver (gold plated)  
Moveable — Gold/platinum/palladium/silver (gold plated)

**Contact Resistance** — Before Life — 100 milliohms max. (measured @ 10 mA @ 6 Vdc)  
After Life — 200 milliohms max. (measured @ 1 A @ 28 Vdc)

**Mechanical Life Expectancy** — 1 million operations

**Coil Voltage** — 5 to 26.5 Vdc

**Coil Power** — 660 mW max. @ 25°C

**Duty Cycle** — Continuous

**Pick-up Voltage** — Approximately 50% of nominal coil voltage

**Pick-up Sensitivity** — 130 mW max. @ 25°C

Contact Ratings

Contact Load	Type	Operations Min.
1.0 A @ 28 Vdc	Resistive	100,000
250 mA @ 115 Vac, 60 Hz & 400 Hz	Resistive (case not grounded)	100,000
100 mA @ 115 Vac, 60 Hz & 400 Hz	Resistive	100,000
0.2 A @ 28 Vdc	Inductive (0.32 Henry)	100,000
0.1 A @ 28 Vdc	Lamp	100,000
30 µA @ 50 mVdc	Low Level	1,000,000
0.1 A @ 28 Vdc	Intermediate Current	50,000



MGAT

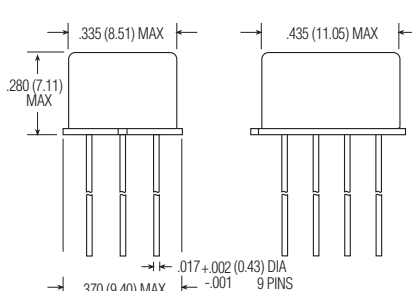

MGAT Enclosure

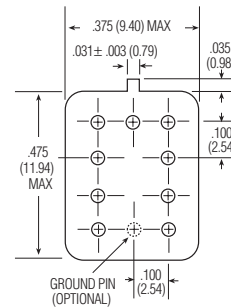

MGAT Header

**Double Pole, Electrically Held, 1 Amp and Less** (Continued)

**MGAT** (Continued)

**Operating Characteristics**

**Timing** —  
Operate Time — 2.0 ms max.  
**Contact Bounce** — 1.5 ms max.  
**Dielectric Withstanding Voltage**  
— Between Open Contacts —  
500 Vrms 60 Hz  
Between Adjacent Contacts —  
500 Vrms 60 Hz  
Between Contacts & Coil —  
500 Vrms 60 Hz  
**Insulation Resistance** —  
10,000 megohms min. @ 500 Vdc  
1,000 megohms @ 500 Vdc  
(coil to case @ +125°C)

**Environmental Characteristics**

**Temperature Range** —  
-65°C to +125°C  
**Weight** —  
0.09 oz. (2.55 gms)  
0.129 oz. (3.45 gms) w/ mounting pad attached  
**Vibration Resistance** —  
30 G's, 10 to 3,000 Hz  
**Shock Resistance** —  
75 G's, 6 ±1 ms max.  
**QPL Approval** —  
MIL-R-28776/6 (JMGAT)

**Semiconductor Characteristics**

**Diode** —  
100 Vdc peak inverse voltage (PIV)  
1.0 Vdc max. transient voltage  
**Zener Diode** —  
20 Vdc ±3 Vdc over temperature range  
**MOSFET** —  
0.5 Vdc min. gate turn-off voltage  
4.3 Vdc max. gate turn-on voltage

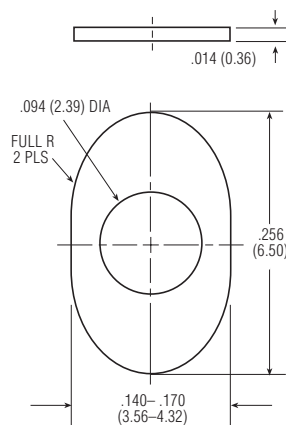

MGAT Mounting Pad

**Coil Data**

Nom. Coil Voltage (Vdc)	Coil Resistance in Ohms ±10% @ 25°C (Note)	Coil Circuit Current mA (Max.) (Note)	Coil Circuit Current mA (Min.) (Note)	Pickup Voltage Vdc (Max.) @ 25°C	Pickup Voltage Vdc (Max.) @ 125°C	Drop-Out Voltage Vdc (Min.) @ 25°C	Drop-Out Voltage Vdc (Min.) @ -65°C	Nom. Coil Power (mW) @ 25°C	Max. Coil Voltage	Coil Desig.
MGAT										
5.0	39	132.3	96.5	2.9	3.5	0.23	0.13	641	5.8	5
6.0	78	83.9	60.3	3.5	4.5	0.32	0.18	462	8.0	6
9.0	220	47.1	33.1	5.3	6.8	0.48	0.27	368	12.0	9
12.0	390	36.1	24.9	7.1	9.0	0.65	0.36	369	16.0	12
18.0	880	24.1	16.1	10.6	13.5	0.97	0.54	368	24.0	18
26.5	1,560	19.9	12.9	14.2	18.0	1.30	0.72	450	32.0	26

**Note:** Coil resistance not directly measurable. Coil current should be within limits shown when tested at nominal voltage at 25°C for 5 seconds max.

**Ordering Instructions**

Catalog-selected Relays: The catalog number is derived by choosing the proper CODE for each of the relay characteristics in the order in which the codes are listed.

**Specifying a Part Number Example:**

**Type**      **Terminals**      **Diodes**      **Ground Pins**      **Coils**      **Mounting Pads**  
MGA                  C                  T                  G                  -26                  W

\* The part number example shown on this page is for catalog items. For a list of specific QPL part numbers, please see the index in Section 15.

Double Pole, Electrically Held, 1 Amp and Less (Continued)

MGST

MGST

Sensitive .100 Grid Diode Suppressed/MOSFET Driven High Performance Relay

Qualified to MIL-R-28776/7

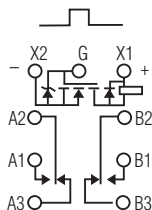

Terminal View

Product Facts

- MOSFET driver, zener & suppression diodes
- Hermetically sealed
- High shock & vibration ratings
- Mounting pads
- Excellent RF switching

Electrical Characteristics

**Contact Arrangement** — 2 Form C (DPDT)

**Contact Material** — Stationary — Gold/platinum/palladium/silver (gold plated)  
Moveable — Gold/platinum/palladium/silver (gold plated)

**Contact Resistance** — Before Life — 100 milliohms max. (measured @ 10 mA @ 6 Vdc)  
After Life — 200 milliohms max. (measured @ 1 A @ 28 Vdc)

**Mechanical Life Expectancy** — 1 million operations

**Coil Voltage** — 5 to 26.5 Vdc

**Coil Power** — 565 mW max. @ 25°C

**Duty Cycle** — Continuous

**Pick-up Voltage** — Approximately 50% of nominal coil voltage

**Pick-up Sensitivity** — 60 mW max. @ 25°C

Contact Ratings

Contact Load	Type	Operations Min.
1.0 A @ 28 Vdc	Resistive	100,000
250 mA @ 115 Vac, 60 Hz & 400 Hz	Resistive (case not grounded)	100,000
100 mA @ 115 Vac, 60 Hz & 400 Hz	Resistive	100,000
0.2 A @ 28 Vdc	Inductive (0.32 Henry)	100,000
0.1 A @ 28 Vdc	Lamp	100,000
30 µA @ 50 mVdc	Low Level	1,000,000
0.1 A @ 28 Vdc	Intermediate Current	50,000

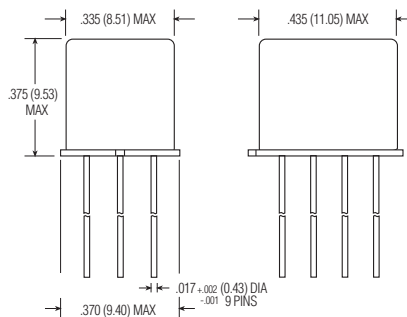
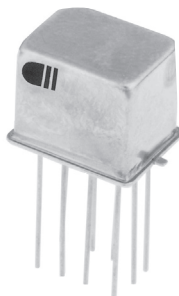

MGST Enclosure

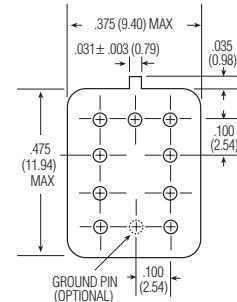

MGST Header

**Double Pole, Electrically Held, 1 Amp and Less** (Continued)

**MGST** (Continued)

**Operating Characteristics**

**Timing** —  
Operate Time — 4.0 ms max.  
Release Time — 7.5 ms max.  
**Contact Bounce** — 1.5 ms max.  
**Dielectric Withstanding Voltage** —  
Between Open Contacts —  
500 Vrms 60 Hz  
Between Adjacent Contacts —  
500 Vrms 60 Hz  
Between Contacts & Coil —  
500 Vrms 60 Hz  
**Insulation Resistance** —  
10,000 megohms min. @ 500 Vdc  
1,000 megohms @ 500 Vdc  
(coil to case @ +125°C)

**Environmental Characteristics**

**Temperature Range** —  
-65°C to +125°C  
**Weight** —  
0.09 oz. (2.55 gms)  
0.129 oz. (3.45 gms) w/ mounting pad attached  
**Vibration Resistance** —  
30 G's, 10 to 3,000 Hz  
**Shock Resistance** —  
75 G's, 6 ±1 ms max.  
**QPL Approval** —  
MIL-R-28776/7 (JMGST)

**Semiconductor Characteristics**

**Diode** —  
100 Vdc peak inverse voltage (PIV)  
1.0 Vdc max. transient voltage  
**Zener Diode** —  
20 Vdc ±3 Vdc over temperature range  
**MOSFET** —  
0.5 Vdc min. gate turn off voltage  
4.3 Vdc max. gate turn on voltage

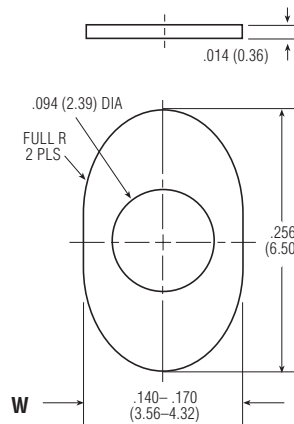

MGST Mounting Pad

**Coil Data**

Nom. Coil Voltage (Vdc)	Coil Resistance in Ohms ±10% @ 25°C (Note)	Coil Circuit Current mA (Max.) (Note)	Coil Circuit Current mA (Min.) (Note)	Pickup Voltage Vdc (Max.) @ 25°C	Pickup Voltage Vdc (Max.) @ 125°C	Drop-Out Voltage Vdc (Min.) @ 25°C	Drop-Out Voltage Vdc (Min.) @ -65°C	Nom. Coil Power (mW) @ 25°C	Max. Coil Voltage	Coil Desig.
MGST										
5.0	100	56.0	43.0	2.9	4.0	0.23	0.13	250	5.6	5
6.0	200	33.0	27.0	3.5	4.9	0.32	0.18	180	8.0	6
9.0	400	26.4	17.8	5.3	7.3	0.48	0.27	203	12.0	9
12.0	800	17.7	11.3	7.1	9.8	0.65	0.36	180	16.0	12
18.0	1,600	13.8	8.4	10.6	14.6	0.97	0.54	203	24.0	18
26.5	3,200	10.2	5.8	14.2	19.5	1.30	0.72	219	32.0	26

**Note:** Coil resistance not directly measurable. Coil current should be within limits shown when tested at nominal voltage at 25°C for 5 seconds max.

**Ordering Instructions**

Catalog-selected Relays: The catalog number is derived by choosing the proper CODE for each of the relay characteristics in the order in which the codes are listed.

**Specifying a Part Number Example:**

<b>Type</b>	<b>Terminals</b>	<b>Diodes</b>	<b>Ground Pins</b>	<b>Coils</b>	<b>Mounting Pads</b>
MGS	C	T	G	-26	W

\* The part number example shown on this page is for catalog items. For a list of specific QPL part numbers, please see the index in Section 15.

Double Pole, Electrically Held, 1 Amp and Less (Continued)

SMGA, SMGAD, SMGADD

**SMGA**  
Standard .100 Grid  
Surface Mount  
High Performance Relay  
Designed to  
MIL-R-39016/17

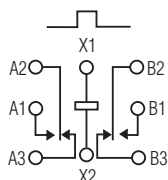

Terminal View

**SMGAD**  
Standard .100 Grid Diode  
Suppressed Surface Mount  
High Performance Relay  
Designed to  
MIL-R-39016/18

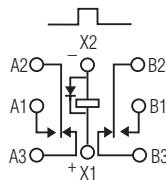

Terminal View

**SMGADD**  
Standard .100 Grid Diode  
Suppressed/Protected  
Surface Mount  
High Performance Relay  
Designed to  
MIL-R-39016/19

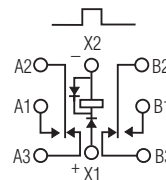

Terminal View

Product Facts

- Hermetically sealed
- High shock & vibration ratings
- Surface mount leads
- Excellent RF switching

Product Facts

- Suppression diode
- Hermetically sealed
- High shock & vibration ratings
- Surface mount leads
- Excellent RF switching

Product Facts

- Suppression & protection diodes
- Hermetically sealed
- High shock & vibration ratings
- Surface mount leads
- Excellent RF switching

Electrical Characteristics

**Contact Arrangement** — 2 Form C (DPDT)

**Contact Material** — Stationary — Gold/platinum/palladium/silver (gold plated)  
Moveable — Gold/platinum/palladium/silver (gold plated)

**Contact Resistance** — Before Life — 100 milliohms max. (measured @ 10 mA @ 6 Vdc)  
After Life — 200 milliohms max. (measured @ 1 A @ 28 Vdc)

**Mechanical Life Expectancy** — 1 million operations

**Coil Voltage** — 5 to 26.5 Vdc

**Coil Power** — 660 mW max. @ 25°C

**Duty Cycle** — Continuous

**Pick-up Voltage** — Approximately 50% of nominal coil voltage

**Pick-up Sensitivity** — 130 mW max. @ 25°C

Contact Ratings

Contact Load	Type	Operations Min.
1.0 A @ 28 Vdc	Resistive	100,000
250 mA @ 115 Vac, 60 Hz & 400 Hz	Resistive (case not grounded)	100,000
100 mA @ 115 Vac, 60 Hz & 400 Hz	Resistive	100,000
0.2 A @ 28 Vdc	Inductive (0.32 Henry)	100,000
0.1 A @ 28 Vdc	Lamp	100,000
30 µA @ 50 mVdc	Low Level	1,000,000
0.1 A @ 28 Vdc	Intermediate Current	50,000

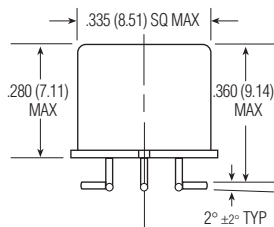

Enclosure

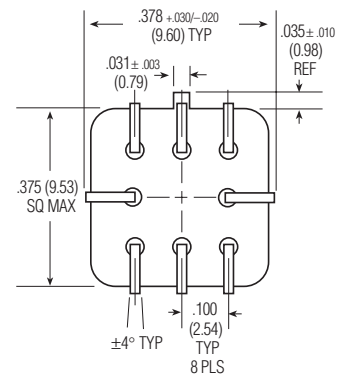

Header

**Double Pole, Electrically Held, 1 Amp and Less** (Continued)

**SMGA, SMGAD, SMGADD**  
(Continued)

**Operating Characteristics**

**Timing** —  
Operate Time — 2.0 ms max.  
Release Time —  
SMGA — 1.5 ms max.  
SMGAD/SMGADD — 4.0 ms max.  
(suppression diode, protection/  
suppression diodes)

**Contact Bounce** — 1.5 ms max.  
**Dielectric Withstanding Voltage**

— Between Open Contacts —  
500 Vrms 60 Hz  
Between Adjacent Contacts —  
500 Vrms 60 Hz  
Between Contacts & Coil —  
500 Vrms 60 Hz

**Insulation Resistance** —  
10,000 megohms min. @ 500 Vdc  
1,000 megohms @ 500 Vdc  
(coil to case @ +125°C)

**Environmental Characteristics**

**Temperature Range** —  
-65°C to +125°C  
**Weight** —  
0.09 oz. (2.55 gms)  
**Vibration Resistance** —  
30 G's, 10 to 3,000 Hz  
**Shock Resistance** —  
75 G's, 6 ±1 ms max.

**Semiconductor Characteristics**

**Diode** —  
100 Vdc peak inverse voltage (PIV)  
1.0 Vdc max. transient voltage

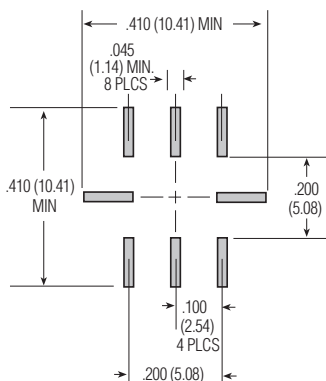

Recommended Solder Pad Layout

**Coil Data**

Nom. Coil Voltage (Vdc)	Coil Resistance in Ohms ±10% @ 25°C (Note)	Coil Circuit Current mA (Max.) (Note)	Coil Circuit Current mA (Min.) (Note)	Pickup Voltage Vdc (Max.) @ 25°C	Pickup Voltage Vdc (Max.) @ 125°C	Drop-Out Voltage Vdc (Min.) @ 25°C	Drop-Out Voltage Vdc (Min.) @ -65°C	Nom. Coil Power (mW) @ 25°C	Max. Coil Voltage	Coil Desig.
<b>SMGA/SMGAD</b>										
5.0	50	n/a	n/a	2.7	3.5	0.22	0.14	500	5.8	5
6.0	98	n/a	n/a	3.5	4.5	0.28	0.18	367	8.0	6
9.0	220	n/a	n/a	5.3	6.8	0.54	0.35	368	12.0	9
12.0	390	n/a	n/a	7.0	9.0	0.63	0.41	369	16.0	12
18.0	880	n/a	n/a	10.5	13.5	0.91	0.59	368	24.0	18
26.5	1,560	n/a	n/a	14.2	18.0	1.37	0.89	450	32.0	26
<b>SMGADD</b>										
5.0	39	128.2	93.2	3.2	4.0	0.6	0.6	641	5.8	5
6.0	78	78.3	58.3	4.0	5.0	0.7	0.7	462	8.0	6
9.0	220	42.9	33.0	6.3	7.8	0.9	0.8	368	12.0	9
12.0	390	32.8	25.6	8.0	10.0	1.1	0.9	369	16.0	12
18.0	880	22.1	17.5	11.5	14.5	1.4	1.1	368	24.0	18
26.5	1,560	18.5	14.8	15.2	19.0	1.8	1.4	450	32.0	26

**Note:** Coil resistance not directly measurable. Coil current should be within limits shown when tested at nominal voltage at 25°C for 5 seconds max.

**Ordering Instructions**

Catalog-selected Relays: The catalog number is derived by choosing the proper CODE for each of the relay characteristics in the order in which the codes are listed.

**Specifying a Part Number Example:**      Type                      Diode                      Coils  
SMGA    D    -26

Double Pole, Electrically Held, 1 Amp and Less (Continued)

SMGS, SMGSD, SMGSDD

**SMGS**  
Sensitive .100 Grid  
Surface Mount  
High Performance Relay  
Designed to  
MIL-R-39016/41

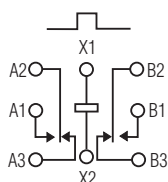

Terminal View

**SMGSD**  
Sensitive .100 Grid Diode  
Suppressed Surface Mount  
High Performance Relay  
Designed to  
MIL-R-39016/42

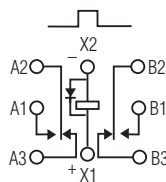

Terminal View

**SMGSDD**  
Sensitive .100 Grid Diode  
Suppressed/Protected  
Surface Mount  
High Performance Relay  
Designed to  
MIL-R-39016/43

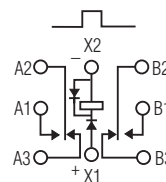

Terminal View

**Product Facts**

- Hermetically sealed
- High shock & vibration ratings
- Surface mount leads
- Excellent RF switching

**Product Facts**

- Suppression diode
- Hermetically sealed
- High shock & vibration ratings
- Surface mount leads
- Excellent RF switching

**Product Facts**

- Suppression & protection diodes
- Hermetically sealed
- High shock & vibration ratings
- Surface mount leads
- Excellent RF switching

**Electrical Characteristics**

**Contact Arrangement** — 2 Form C (DPDT)

**Contact Material** — Stationary — Gold/platinum/palladium/silver (gold plated)  
Moveable — Gold/platinum/palladium/silver (gold plated)

**Contact Resistance** — Before Life — 100 milliohms max. (measured @ 10 mA @ 6 Vdc)  
After Life — 200 milliohms max. (measured @ 1 A @ 28 Vdc)

**Mechanical Life Expectancy** — 1 million operations

**Coil Voltage** — 5 to 48 Vdc  
**Coil Power** — 565 mW max. @ 25°C

**Duty Cycle** — Continuous  
**Pick-up Voltage** — Approximately 50% of nominal coil voltage  
**Pick-up Sensitivity** — 130 mW max. @ 25°C

**Contact Ratings**

Contact Load	Type	Operations Min.
1.0 A @ 28 Vdc	Resistive	100,000
250 mA @ 115 Vac, 60 Hz & 400 Hz	Resistive (case not grounded)	100,000
100 mA @ 115 Vac, 60 Hz & 400 Hz	Resistive	100,000
0.2 A @ 28 Vdc	Inductive (0.32 Henry)	100,000
0.1 A @ 28 Vdc	Lamp	100,000
30 µA @ 50 mVdc	Low Level	1,000,000
0.1 A @ 28 Vdc	Intermediate Current	50,000

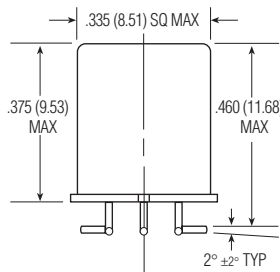
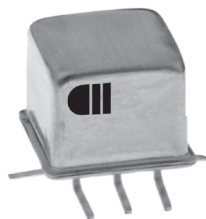

Enclosure

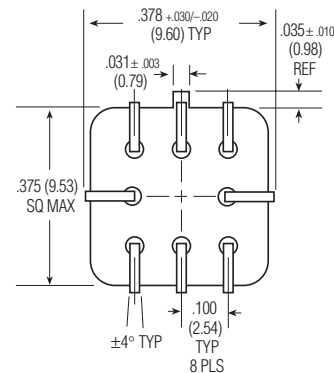

Header

**Double Pole, Electrically Held, 1 Amp and Less** (Continued)

**SMGS, SMGSD, SMGSDD**  
(Continued)

**Operating Characteristics**

**Timing** —  
Operate Time — 4.0 ms max.  
Release Time —  
SMGS — 2.0 ms max.  
SMGSD/SMGSDD — 7.5 ms max.  
(suppression diode, protection/  
suppression diodes)

**Contact Bounce** — 1.5 ms max.  
**Dielectric Withstanding Voltage**

— Between Open Contacts —  
500 Vrms 60 Hz  
Between Adjacent Contacts —  
500 Vrms 60 Hz  
Between Contacts & Coil —  
500 Vrms 60 Hz

**Insulation Resistance** —  
10,000 megohms min. @ 500 Vdc  
1,000 megohms @ 500 Vdc  
(coil to case @ +125°C)

**Environmental Characteristics**

**Temperature Range** —  
-65°C to +125°C

**Weight** —  
0.09 oz. (2.55 gms)

**Vibration Resistance** —  
30 G's, 10 to 3,000 Hz

**Shock Resistance** —  
75 G's, 6 ±1 ms max.

**Semiconductor Characteristics**

**Diode** —  
100 Vdc peak inverse voltage (PIV)  
1.0 Vdc max. transient voltage

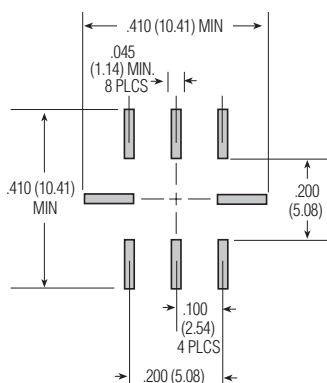

Recommended Solder Pad Layout

**Coil Data**

Nom. Coil Voltage (Vdc)	Coil Resistance in Ohms ±10% @ 25°C (Note)	Coil Circuit Current mA (Max.) (Note)	Coil Circuit Current mA (Min.) (Note)	Pickup Voltage Vdc (Max.) @ 25°C	Pickup Voltage Vdc (Max.) @ 125°C	Drop-Out Voltage Vdc (Min.) @ 25°C	Drop-Out Voltage Vdc (Min.) @ -65°C	Nom. Coil Power (mW) @ 25°C	Max. Coil Voltage	Coil Desig.
<b>SMGS/SMGSD</b>										
5.0	100	n/a	n/a	2.6	3.5	0.23	0.12	250	7.5	5
6.0	200	n/a	n/a	3.4	4.5	0.28	0.18	180	10.0	6
9.0	400	n/a	n/a	4.85	6.8	0.55	0.35	203	15.0	9
12.0	800	n/a	n/a	7.0	9.0	0.64	0.41	180	20.0	12
18.0	1,600	n/a	n/a	9.8	13.5	0.92	0.59	203	30.0	18
26.5	3,200	n/a	n/a	14.0	18.0	1.4	0.89	219	40.0	26
36.0	6,500	n/a	n/a	20.0	27.0	1.8	1.25	199	57.0	36
48.0	11,000	n/a	n/a	25.8	36.0	2.4	1.60	209	75.0	48
<b>SMGSDD</b>										
5.0	64	78.1	56.8	2.9	3.7	0.8	0.7	391	7.5	5
6.0	125	48.9	36.3	4.0	4.8	0.9	0.8	288	10.0	6
9.0	400	23.6	18.1	6.1	8.0	1.1	0.9	203	15.0	9
12.0	800	16.0	12.5	7.8	11.0	1.3	1.0	180	20.0	12
18.0	1,600	12.2	9.6	11.3	14.5	1.5	1.1	203	30.0	18
26.5	3,200	9.0	7.2	15.2	19.0	1.7	1.3	219	40.0	26
36.0	6,500	6.1	4.9	21.7	27.2	2.3	1.7	199	57.0	36
48.0	11,000	4.8	3.9	27.8	34.8	2.8	2.0	209	75.0	48

**Note:** Coil resistance not directly measurable. Coil current should be within limits shown when tested at nominal voltage at 25°C for 5 seconds max.

**Ordering Instructions**

Catalog-selected Relays: The catalog number is derived by choosing the proper CODE for each of the relay characteristics in the order in which the codes are listed.

**Specifying a Part Number Example:**      **Type**              **Diode**              **Coils**  
SMGS    D    -26

**Double Pole, Electrically Held, 1 Amp and Less** (Continued)

SHC, SHCD, SHCS, SHCSD



SHC, SHCS

**Standard / Sensitive  
.100 Grid Surface Mount  
Commercial Relay**

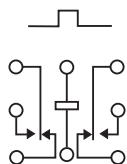

Terminal View

SHCD, SHCSD

**Standard / Sensitive  
.100 Grid Surface Mount  
Diode Suppressed  
Commercial Relay**

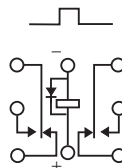

Terminal View

**Product Facts**

- Hermetically sealed
- Excellent RF switching

**Product Facts**

- Suppression Diode
- Hermetically sealed
- Excellent RF switching

**Electrical Characteristics**

**Contact Arrangement** —

2 Form C (DPDT)

**Contact Material** —

Stationary —

Gold/platinum/palladium/silver alloy  
(gold plated)

Moveable —

Gold/platinum/palladium/silver alloy  
(gold plated)

**Contact Resistance** —

Before Life — 100 milliohms max.

(measured @ 10 mA @ 6 Vdc)

After Life — 200 milliohms max.

(measured @ 1 A @ 28 Vdc)

**Mechanical Life Expectancy** —

1 million operations

**Coil Voltage** —

5 to 26.5 Vdc (SHC/SHCD)

5 to 48 Vdc (SHCS/SHCSD)

**Coil Power** —

SHC/SHCD — 660 mW max. @ 25°C

SHCS/SHCSD — 565 mW max. @ 25°C

**Duty Cycle** — Continuous

**Pick-up Voltage** — Approximately

70% of nominal coil voltage

**Pick-up Sensitivity** —

SHC/SHCD — 180 mW max. @ 25°C

SHCS/SHCSD — 90 mW max. @ 25°C

**Contact Ratings**

Contact Load	Type	Operations Min.
1.0 A @ 28 Vdc	Resistive	100,000
250 mA @ 115 Vac, 60 Hz & 400 Hz	Resistive (Case not grounded)	100,000
100 mA @ 115 Vac, 60 Hz & 400 Hz	Resistive	100,000
0.2 A @ 28 Vdc	Inductive (0.32 Henry)	100,000
0.1 A @ 28 Vdc	Lamp	100,000
30 μA @ 50 mVdc	Low Level	1,000,000

Double Pole, Electrically Held, 1 Amp and Less (Continued)

SHC, SHCD, SHCS, SHCSD

(Continued)

Operating Characteristics

Timing —

- Operate Time —
- SHC/SHCD — 4.0 ms max.
- SHCS/SHCSD — 6.0 ms max.
- Release Time —
- SHC — 3.0 ms max.
- SHCS — 3.0 ms max.
- SHCD — 6.0 ms max.
- (suppression diode)
- SHCSD — 7.5 ms max.
- (suppression diode)

Dielectric Withstanding Voltage —

- Between Open Contacts —
- 350 Vrms 60 Hz
- Between Adjacent Contacts —
- 350 Vrms 60 Hz
- Between Contacts & Coil —
- 350 Vrms 60 Hz

Insulation Resistance —

1,000 megohms @ 500 Vdc

Environmental Characteristics

Temperature Range —

-55°C to +85°C

Weight —

- SHC/SHCD —
- 0.09 oz. (2.55 gms)
- SHCS/SHCSD —
- 0.15 oz. (4.30 gms)

Vibration Resistance —

10 G's, 10 to 500 Hz

Shock Resistance —

30 G's, 6 ±1 ms

Semiconductor Characteristics

Diode —

- 100 Vdc peak inverse voltage (PIV)
- 1.0 Vdc max. transient voltage

Standard Coil Data

	Nom. Coil Voltage (Vdc)	Coil Resistance in Ohms ±20% @ 25°C	Pickup Voltage Vdc (Max.) @ 25°C	Nom. Coil Power (mW) @ 25°C	Max. Coil Voltage	Coil Desig.
SHC/SHCD	5.0	64	3.8	391	5.8	5
	6.0	98	4.9	367	8.0	6
	9.0	220	7.0	368	12.0	9
	12.0	400	9.0	360	16.0	12
	18.0	880	14.0	368	24.0	18
	26.5	1,600	18.0	439	32.0	26
SHCS/SHCSD	5.0	100	3.5	250	7.5	5
	6.0	200	4.5	180	10.0	6
	9.0	400	6.8	203	15.0	9
	12.0	800	9.0	180	20.0	12
	18.0	1,600	13.5	203	30.0	18
	26.5	3,200	18.0	219	40.0	26
	36.0	6,500	24.0	199	57.0	36
	48.0	11,000	32.0	209	75.0	48

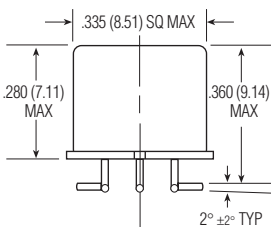

SHC/SHCD Enclosure

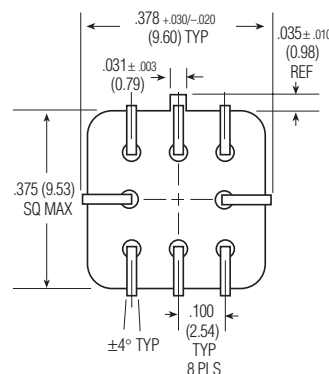

SHC/SHCD/SHCS/SHCSD Header

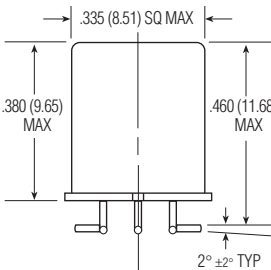

SHCS/SHCSD Enclosure

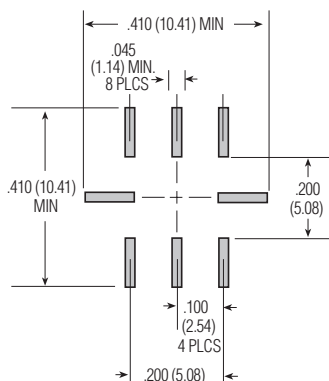

Recommended Solder Pad Layout

Ordering Instructions

Catalog-selected Relays: The catalog number is derived by choosing the proper CODE for each of the relay characteristics in the order in which the codes are listed.

Specifying a Part Number Example:

<b>Type</b>	<b>Diodes</b>	<b>Coils</b>
SHC	D	-26

## Double Pole, Electrically Held, 2 Amps and Less

HFW, HMB, HMS

**HFW**  
Standard Half Size  
High Performance Relay  
Qualified to  
MIL-R-39016/6

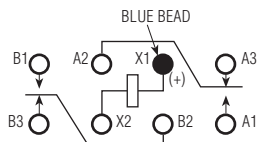
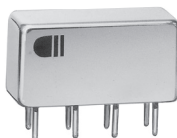

Terminal View

**HMB**  
Bifilar Half Size  
High Performance Relay  
Qualified to  
MIL-R-39016/22

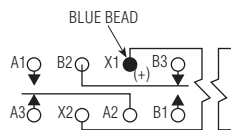
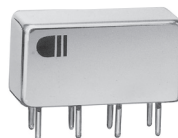

Terminal View

**HMS**  
Sensitive Half Size  
High Performance Relay  
Qualified to  
MIL-R-39016/44

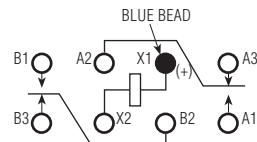
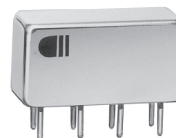

Terminal View

### Product Facts

- Hermetically sealed
- Up to 2 amps switching
- High shock & vibration ratings
- Optional terminals & mounting styles
- Excellent RF switching

### Product Facts

- Hermetically sealed
- Up to 2 amps switching
- High shock & vibration ratings
- Optional terminals & mounting styles
- Excellent RF switching

### Product Facts

- Hermetically sealed
- Up to 2 amps switching
- High shock & vibration ratings
- Optional terminals & mounting styles
- Excellent RF switching

### Electrical Characteristics

**Contact Arrangement** —  
2 Form C (DPDT)

**Contact Material** —  
Stationary —  
Hardened silver alloy  
Moveable —  
Gold plated hardened silver alloy

**Contact Resistance** —  
Before Life — 50 milliohms max.  
(measured at 10 mA @ 6 Vdc)  
After Life — 100 milliohms max.  
(measured @ 2 A @ 28 Vdc)

**Mechanical Life Expectancy** —  
50 million operations

**Coil Voltage** —  
5 to 48 Vdc (HFW)  
6 to 26.5 Vdc (HMB)  
5 to 36 Vdc (HMS)

**Coil Power** — 1.4 watts max. @ 25°C

**Duty Cycle** — Continuous

**Pick-up Voltage** — Approximately  
50% of nominal coil voltage

**Pick-up Sensitivity @ 25°C** —  
145 to 260 mW (HFW)  
325 mW (HMB)  
100 to 125 mW (HMS)

### Contact Ratings

Contact Load	Type	Operations Min.
2 A @ 28 Vdc	Resistive	100,000
0.75 A @ 28 Vdc	Inductive (200mH)	100,000
0.1 A @ 115 Vac, 60 Hz & 400 Hz	Resistive	100,000
0.3 A @ 115 Vac, 60 Hz & 400 Hz	Resistive	100,000
0.1 A @ 28 Vdc	Intermediate	50,000
0.160 A @ 28 Vdc	Lamp	100,000
30 μA @ 50 mVdc	Low Level	1,000,000

### RF Performance

Frequency (MHz)	RF Losses (dB)	VSWR	Isolation (dB)
100	0.1	1.17:1	40
500	0.3	1.19:1	28
1000	0.4	1.19:1	23

Double Pole, Electrically Held, 2 Amps and Less (Continued)

HFW, HMB, HMS (Continued)

Operating Characteristics

**Timing** —  
 Operate Time —  
 4.0 ms max. (HFW)  
 5.0 ms max. (HMB)  
 6.0 ms max. (HMS)  
 Release Time —  
 4.0 ms max. (HFW)  
 5.0 ms max. (HMB/HMS)  
**Contact Bounce** — 2.0 ms max.  
**Dielectric Withstanding Voltage**  
 — Between Open Contacts —  
 500 Vrms 60 Hz  
 Between Adjacent Contacts —  
 1000 Vrms 60 Hz  
 Between Contacts & Coil —  
 1000 Vrms 60 Hz  
**Insulation Resistance** —  
 10,000 megohms min. @ 500 Vdc

Environmental Characteristics

**Temperature Range** —  
 -65°C to +125°C  
**Weight** — 0.46 oz. (13 gms max.)  
**Vibration Resistance** — HFW/HMB/  
 HMS —  
 Standard — 20 G's, 10 to 2,000 Hz  
 HFW/HMB —  
 QPL — 30 G's, 10 to 3,000 Hz  
 HMS —  
 QPL — 20 G's, 10 to 2,500 Hz  
**Shock Resistance** —  
 100 G's, 6 ± 1 ms  
 50 G's, 11 ± 1 ms (HMS)  
**QPL Approval** —  
 MIL-R-39016/6 (HFW)  
 MIL-R-39016/22 (HMB)  
 MIL-R-39016/44 (HMS)

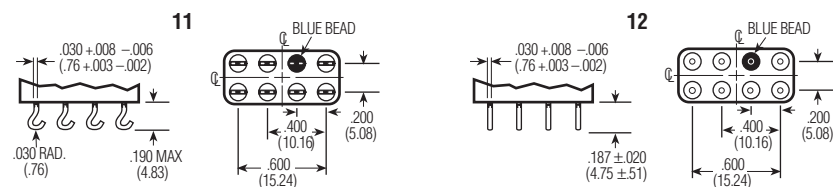

Terminals

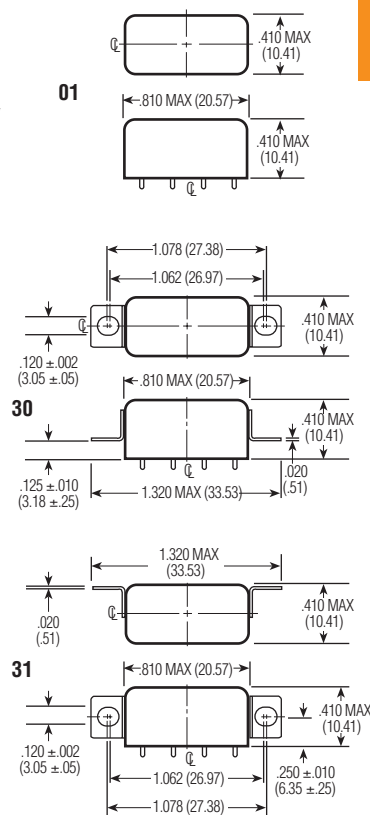

Mounting Styles

Standard Coil Data

	Nom. Coil Voltage (Vdc)	Coil Resistance in Ohms ±10% @ 25°C	Pickup Voltage Vdc (Max.) @ 25°C	Pickup Voltage Vdc (Min.) @ 125°C	Drop-out Voltage Vdc (Min.) @ 25°C	Drop-out Voltage Vdc (Min.) @ -65°C	Nom. Coil Power (mW) @ 25°C	Max. Coil Voltage	Coil Desig.
HFW	5.0	27	2.7	3.8	0.29	0.21	926	6.0	L
	6.0	40	3.2	4.5	0.35	0.25	900	7.5	F
	12.0	160	6.4	9.0	0.7	0.5	900	15.0	G
HMB	26.5	700	13.5	18.0	1.5	1.0	1003	32.0	K
	6.0	40	3.6	4.8	0.35	0.25	900	7.5	F
	12.0	160	7.2	9.6	0.7	0.5	900	15.0	G
HMS	26.5	700	15.0	20.0	1.5	1.0	1003	32.0	K
	5.0	47	2.2	3.2	0.21	0.12	532	7.0	S001
	6.0	75	2.75	4.0	0.27	0.17	480	9.0	S002
Other	12.0	310	5.6	8.0	0.55	0.35	465	20.0	S003
	26.5	1,030	11.4	16.5	1.1	0.7	682	35.0	S004
	30.0	1,620	14.3	21.0	1.4	0.9	556	44.0	S005
	36.0	2,640	18.0	26.0	1.8	1.1	491	56.0	S006
(avail. for HFW relays only)	6-8	60	3.5	4.85	0.35	0.22	817	9.0	A
	12-15	320	6.8	9.42	0.68	0.44	570	21.0	B
	18.0	520	9.5	13.16	0.95	0.62	623	27.0	J
	26.5-32	1,250	14.0	19.4	1.5	0.98	684	42.0	D
	40.0	2,700	21.3	29.5	2.1	1.37	593	61.0	H
	48.0	3,500	25.5	35.3	2.5	1.63	658	70.0	E

Specifying a Part Number Example:

**Type** HFW    **Terminals** 12    **Mountings** 30    **Coils** K    **Features** 00 (n/a HMS)

\* The part number example shown on this page is for catalog items. For a list of specific QPL part numbers, please see the index in Section 15.

Double Pole, Electrically Held, 2 Amps and Less (Continued)

Long-life Half size Industrial Relay  
Type 3SCV (2PDT)

Product Facts

- 100,000,000 operations at low-level
- Hermetic seal

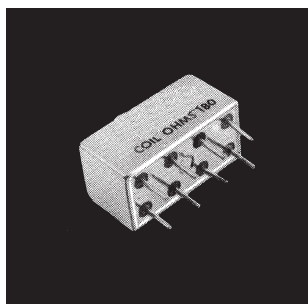

The 3SCV is an exceptionally long life relay for low level applications which is designed for industrial applications such as business machines and computer peripheral equipment. The design is such that the phenomenon of sticking contacts is all but eliminated. Because of its low contact resistance and its ability to handle overloads the 3SCV relay is well suited for applications which have previously required reed devices.

Electrical Characteristics

- Contacts** — 2 Form C
- Contact Resistance** — 0.050 ohms; 0.100 ohms after life test
- Life** — 10<sup>5</sup>-2A 28 volts DC, 115 volts AC (not grounded, resistive) 0.5A
- Low-level** — 100,000,000 operations — 50 µA at 50 mV Peak AC or DC
- Sensitivity** — 340 mW

Operating Characteristics

- Operate Time** — 6 ms max.
- Release Time** — 4 ms max.
- Contact Bounce** — 2 ms max.
- Enclosure** — All welded, hermetically sealed
- Terminals** — Weldable and solderable
- Dielectric Strength** — 500 volts rms at sea level
- Insulation Resistance** — 1,000 megohm min.

Environmental Characteristics

- Weight** — 0.30 oz.
- Vibration** — 10G, 10-2000 Hz
- Shock** — 50 G 6ms, 1/2 sine
- Temperature** — -14°C to +125°C

See page 1-39 for Mounting Forms, Terminals and Circuit Diagrams.

Coil Table (All Values DC)\* 340 mW Sensitivity: (Code 1)

Coil Code Letter	Coil Resistance at 25C (ohms)	Voltage Calibrated, CODE: 5			
		Suggested Source Volts†	Maximum Operate Volts at 25C	Release Voltage Range at 25C	
				Max	Min
A	47 ± 10%	4.8-7	3.9	2.7	.43
B	75 ± 10%	6.1-9	4.9	3.4	.5
C	120 ± 10%	7.7-12	6.3	4.4	.69
D	180 ± 10%	9.5-15	7.7	5.4	.85
E	310 ± 10%	12.5-20	10.1	7.0	1.1
F	440 ± 10%	15.0-23	12.0	8.4	1.3
H	700 ± 10%	20.0-30	15.5	10.9	1.7
K	1030 ± 10%	24.0-35	18.5	12.9	2.0
L	1620 ± 10%	30.0-44	23.1	16.2	2.5
M	2640 ± 10%	39.0-56	29.5	20.68	3.2

Ordering Instructions

Catalog-selected Relays: The catalog number is derived by choosing the proper CODE for each of the six relay characteristics in the order in which the codes are listed.

**Example:** The relay selected in this example is a 2PDT half size relay, voltage calibrated, two-hole side bracket mounting, solder hook header, 700 ohms coil resistance, and 340 mW sensitivity. By choosing the proper code for each of these relay characteristics, the catalog number is identified as 3SCV5042H1. The letter R following sensitivity code indicates relay received 5000 operation miss-test. Ex. 3SCV5042H1R.

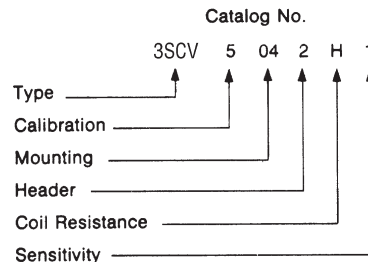

Double Pole, Electrically Held, 2 Amps and Less (Continued)

Mounting Forms (3SCV)

No Mount

Mounting Code
00

\* Assumes relay held securely by potting or other means.

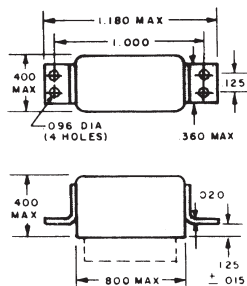
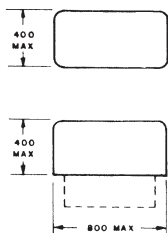

All dimensions in inches

TOLERANCES	
(Unless otherwise specified)	
Hundredths	±0.020
Thousandths	±0.005

Four-hole End Bracket

Mounting Code
01

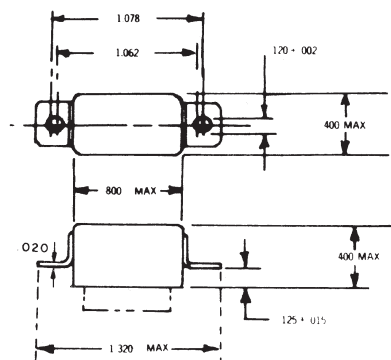

Two-hole elliptical END bracket

Mounting Code
53

Two-hole elliptical Side Bracket

Mounting Code
54

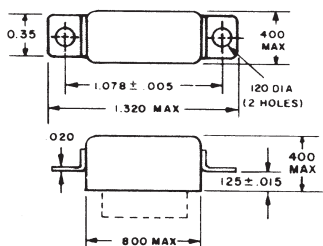
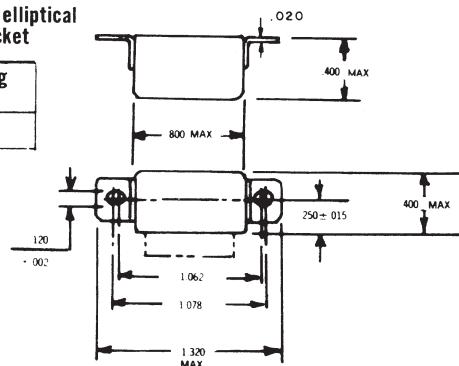

Two-hole End Bracket

Mounting Code
13

Two-hole Side Bracket

Mounting Code
04

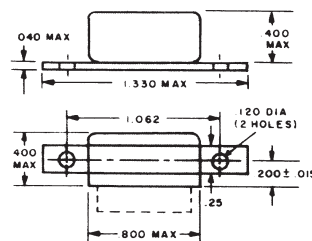

Header and Connection Diagrams

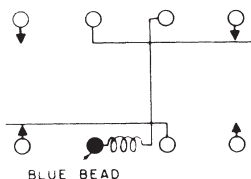
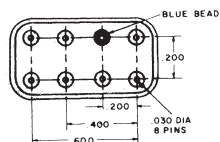

Header Types

Type	Z Dim.	Header Code
Solder hook	0.16	2
Straight pin (socket or PCB type)	0.19	4

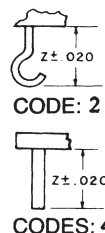

Double Pole, Electrically Held, 2 Amps and Less (Continued)

**HFC**  
Commercial/Industrial  
Half Size Relay

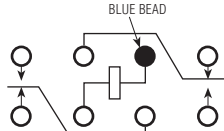
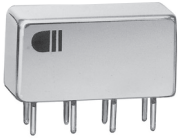

Terminal View

**Electrical Characteristics**

**Contact Arrangement** — 2 Form C (DPDT)  
**Contact Material** — Stationary — Bifurcated hardened silver alloy  
 Moveable — Gold plated hardened alloy  
**Contact Resistance** — Before Life — 50 milliohms max. (measured at 10 mA @ 6 Vdc)  
 After Life — 100 milliohms max. (measured @ 2 A @ 28 Vdc)  
**Mechanical Life Expectancy** — 10 million operations  
**Coil Voltage** — 5 to 26.5 Vdc  
**Coil Power** — 1.4 watts max. @ 25°C  
**Duty Cycle** — Continuous

**Pick-up Voltage** — Approximately 60% of nominal coil voltage

**Pick-up Sensitivity** — 360 mW

**Operating Characteristics**

**Timing** — Operate Time — 6.0 ms max.  
 Release Time — 6.0 ms max.

**Dielectric Withstanding Voltage**

— Between Open Contacts — 350 Vrms 60 Hz  
 Between Adjacent Contacts — 500 Vrms 60 Hz  
 Between Contacts and Coil — 500 Vrms 60 Hz

**Insulation Resistance** — 1,000 megohms min @ 500 Vdc

**Environmental Characteristics**

**Temperature Range** — -55°C to +85°C

**Weight** — 0.46 oz. (13 gms) max.

**Vibration Resistance** — 10 G's, 10 to 500 Hz

**Shock Resistance** — 30 G's, 6 ±1 ms

**Product Facts**

- Hermetically sealed
- Up to 2 amps switching
- Economical configuration
- Optional terminals & mounting styles

**Contact Ratings**

Contact Load	Type	Operations Min.
2 A @ 28 Vdc	Resistive	100,000
0.75 A @ 28 Vdc	Inductive (200 mH)	100,000
0.3 A @ 115 Vac, 60 Hz & 400 Hz	Resistive	100,000

**Standard Coil Data**

Nom. Coil Voltage (Vdc)	Coil Resistance in Ohms ± 20% @ 25°C	Pickup Voltage Vdc (Max.) @ 25°C	Pickup Voltage Vdc (Max.) @ 85°C	Nom. Coil Power (W) @ 25°C	Max. Coil Voltage	Coil Desig.
5.0	27	3.0	3.7	.92	6.0	L
6.0	40	3.6	4.5	.90	7.5	F
12.0	160	7.2	8.9	.90	15.0	G
26.5	700	16.0	19.7	1.00	32.0	K

01

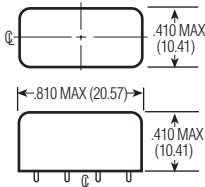

30

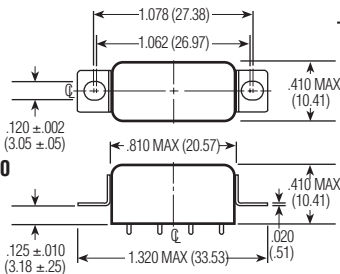

31

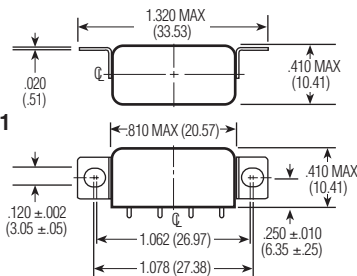

Mounting Styles

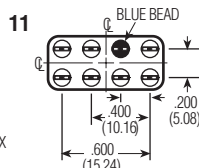
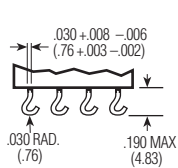

Terminals

**Ordering Instructions**

Catalog-selected Relays: The catalog number is derived by choosing the proper CODE for each of the six relay characteristics in the order in which the codes are listed.

Specifying a Part Number Example:

Type	Terminals	Mountings	Coils	Features
HFC	12	30	K	00

**Double Pole, Electrically Held, 2 Amps and Less** (Continued)

**.150 Grid-space Relays**  
**Type 3SBC (2PDT) Standard**  
**135 mW 2PDT**  
**50 mW (Form AB)**  
**1 PNC-1 PNO**

**Product Facts**

- Low profile... only 0.32 inches high
- Internal diode for coil transient suppression and transistor driven models available
- Qualified to MIL-R-39016/13
- RF designs available

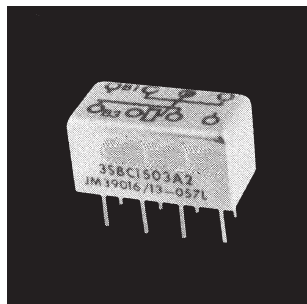

The .150 Grid-space relay — only 0.32 inches high — saves space in electronic packaging. The pin spacing allows you to insert the relay with no intermediate pin spreaders as well as meet applicable military specifications.

**Electrical Characteristics**

**Contact Ratings** —  
 DC resistive — 2 amps at 28 volts (50,000 operations)  
 1 Amp @ 28 V (100,000 operations)  
 DC inductive — 0.5 amps at 28 volts, 200 mH  
 AC resistive — 0.5 amps at 115 volts  
 AC — 0.125 amps at 115 volts (case grounded)  
 Low-level — 50  $\mu$ A at 50 mV  
 Peak AC or DC

**Contact Resistance** —  
 0.050 ohms max.; 0.150 ohms after life test

**Life** — 100,000 operations at rated loads listed; 1,000,000 operations at low-level loads

**Operating Characteristics**

**Operate Time** — 4 ms max.  
**Release Time** — 4 ms max.  
**Contact Bounce** — 1.5 ms  
**Dielectric Strength** —  
 500 volts rms at sea level;  
 350 volts rms at 70,000 feet and above  
**Insulation Resistance** — 1,000 megohm min. over temperature range

**Environmental Characteristics**

**Vibration** — 30G, to 3000 Hz  
**Shock** — 100 G at 11 ms  
**Temperature** — -65°C to +125°C

See page 1-44 for Mounting Forms, Terminals and Circuit Diagrams.

**Coil Table Type 3SBC (All Values DC)\*2PDT, 135 mW Sensitivity: (Code 1)**

Coil Code Letter	Coil Resistance @ 25C (ohms)	Voltage Calibrated, Code 5				Current Calibrated, Code 6			
		Suggested Source Volts†	Max. Operate Volts @ 25C	Release Voltage Range @ 25C		Max. Continuous Current @ 125C (mA)	Max. Operate Current @ 25C (mA)	Release Current Range @ 25C (mA)	
				Max.	Min.			Max.	Min.
A	44 ± 10%	3.5-6.2	2.4	1.45	0.26	87.0	54.5	32.7	6.00
B	56 ± 10%	4.0-7.0	2.7	1.6	0.3	77.0	48.3	28.6	5.30
D	140 ± 10%	6.4-12.0	4.4	2.6	0.5	50.3	31.4	18.5	3.60
E	210 ± 10%	8.0-16.0	5.4	3.2	0.6	40.0	25.7	15.4	2.80
L	650 ± 10%	13.6-24.0	9.5	5.6	1.0	22.9	14.3	8.6	1.54
K	1350 ± 10%	20.0-35.0	13.5	8.1	1.5	15.5	10.0	6.0	1.10
N	2245 ± 10%	26.0-46.0	17.1	10.5	1.9	12.0	7.6	4.7	0.84

**Coil-Data (All Values DC)\* Type 3SBC Form AB 50 mW Sensitivity non mil spec: (Code 2)**

Coil Code Letter	Coil Resistance @ 25C (ohms)	Voltage Calibrated, Code 5				Current Calibrated, Code 6			
		Suggested Source Volts†	Max. Operate Volts @ 25C	Release Voltage Range @ 25C		Max. Continuous Current @ 125C (mA)	Max. Operate Current @ 25C (mA)	Release Current Range @ 25C (mA)	
				Max.	Min.			Max.	Min.
B	56 ± 10%	2.6-7.0	1.8	1.1	0.16	46.5	29.1	18.2	3.30
C	85 ± 10%	3.3-9.5	2.3	1.4	0.20	38.7	24.2	15.1	2.70
D	140 ± 10%	4.3-12.0	2.9	1.8	0.27	30.4	19.0	11.9	2.10
E	210 ± 10%	5.3-14.0	3.6	2.2	0.33	24.8	15.5	9.7	1.75
F	360 ± 10%	6.7-19.0	4.5	2.8	0.41	18.9	11.8	7.2	1.30
G	510 ± 10%	8.2-23.0	5.6	3.5	0.51	15.8	9.9	6.2	1.10
H	775 ± 10%	10.0-26.0	6.8	4.2	0.62	12.8	8.0	5.0	0.90
K	1350 ± 10%	13.2-35.0	9.0	5.6	0.82	9.8	6.1	3.8	0.68
N	2245 ± 10%	16.8-46.0	11.4	7.1	1.00	7.4	4.6	2.9	0.52

\*Values listed are factory test and inspection data. User should allow for meter variations.

†At nominal resistance plus 10%.

‡Applicable over the operating temperature range in circulating air.

See Page 1-42 for ordering instructions.

\* The part number example shown on this page is for catalog items. For a list of specific QPL part numbers, please see the index in Section 15.

Double Pole, Electrically Held, 2 Amps and Less (Continued)

.150 Grid-space  
Hybrid Relays  
Single Diode, Dual Diode  
Type 3SBC (2PDT)  
135 mW

Product Facts

- Low profile... only 0.32 inches high
- 50 milliwatt forms available
- Qualified to MIL-R-39016/37
- Qualified to MIL-R-39016/38
- RF designs available

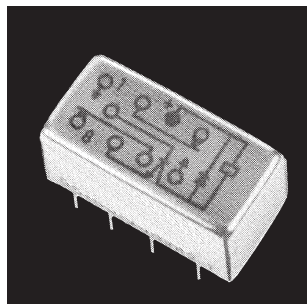

The hybrid .150 Grid-space relay — only 0.32 inches high — saves space in electronic packaging. The pin spacing allows you to insert the relay with no intermediate pin spreader.

Electrical Characteristics

**Contact Ratings** —  
DC resistive — 2 amps at 28 volts (50,000 operations)  
1 Amp @ 28 V (100,000 operations)  
DC inductive — 0.5 amps at 28 volts, 200 mH  
AC resistive — 0.5 amps at 115 volts  
AC — 0.125 amps at 115 volts (case grounded)  
Low-level — 50 µA at 50 mV  
Peak AC or DC

**Contact Resistance** —  
0.050 ohms max.; 0.150 ohms after life test

**Life** — 100,000 operations at rated loads listed; 1,000,000 operations at low-level loads

Operating Characteristics

**Operate Time** — 4 ms max.  
**Release Time** — 6 ms max.  
**Contact Bounce** — 1.5 ms  
**Dielectric Strength (Note 1)** —  
500 volts rms at sea level;  
350 volts rms at 70,000 feet and above  
**Insulation Resistance (Note 1)** —  
1,000 megohm min. over temperature range

Environmental Characteristics

**Vibration** — 30G, to 3000 Hz  
**Shock** — 100 G at 11 ms  
**Temperature** — -65°C to +125°C

Semiconductor Characteristics at 25°C

**Diode** —  
Max. Negative Transient — 1.0 volt  
Breakdown Voltage — 100 VDC @ 10 µA  
Max. Leakage Current — 1 µA @ 50 VDC

See page 1-44 for Mounting Forms, Terminals and Circuit Diagrams.

Coil Table Single Diode (All Values DC)\*(2DPT), 135 mW Sensitivity: (Code 5)

Coil Code Letter	Coil Resistance (@ 25C (ohms)	Voltage Calibrated, Code 5				Current Calibrated, Code 6			
		Suggested Source Volts†	Max. Operate Volts (@ 25C	Release Voltage Range @ 25C		Max. Continuous Current @ 125C (mA)	Max. Operate Current @ 25C (mA)	Release Current Range @ 25C (mA)	
				Max.	Min.			Max.	Min.
A	44 ± 10%	3.5- 6.2	2.4	1.45	0.26	87.0	54.5	32.7	6.00
B	56 ± 10%	4.0- 7.0	2.7	1.6	0.3	77.0	48.3	28.6	5.30
D	140 ± 10%	6.4-12.0	4.4	2.6	0.5	50.3	31.4	18.5	3.60
E	210 ± 10%	8.0-16.0	5.4	3.2	0.6	40.0	25.7	15.4	2.80
L	650 ± 10%	13.6-24.0	9.5	5.6	1.0	22.9	14.3	8.6	1.54
K	1350 ± 10%	20.0-35.0	13.5	8.1	1.5	15.5	10.0	6.0	1.10
N	2245 ± 10%	26.0-46.0	17.1	10.5	1.9	12.0	7.6	4.7	0.84

Coil Table Dual Diode (All Values DC)\*(2DPT), 135 mW Sensitivity: (Code 6)

Coil Code Letter	Coil Resistance (@ 25C (ohms)	Suggested Source Volts†	Max. Operate Volts (@ 25C	Max.	Min.	Max. Continuous Current @ 125C (mA)	Max. Operate Current @ 25C (mA)	Max.	Min.
A	44 ± 10%	3.9- 7.0	3.4	2.0	0.37	98.2	77.3	45.5	8.4
B	56 ± 10%	4.6- 8.0	3.7	2.2	0.41	89.8	66.1	39.3	7.1
D	140 ± 10%	7.8-12.0	5.4	3.2	0.6	52.4	38.6	22.9	4.3
E	210 ± 10%	9.3-16.0	6.4	3.8	0.7	41.4	30.5	18.1	3.3
L	650 ± 10%	15.0-24.0	10.5	6.2	1.1	23.6	16.2	9.5	1.7
K	1350 ± 10%	21.0-35.0	14.5	8.7	1.6	16.0	10.7	6.4	1.2
N	2245 ± 10%	27.0-46.0	18.1	10.9	2.0	12.1	8.1	4.9	0.9

Ordering Instructions

**Example:** The relay selected in the example is a FORM AB .150-grid relay, current calibrated, end bracket mounting with 0.13-inch solder hook header, 210 ohms coil resistance, and 50 mW sensitivity. By choosing the proper code for each of these relay characteristics, the catalog number is 3SBC6131E2. The letter R following sensitivity code indicates relay received 5000 operation miss-test. Ex. 3SBC6131E2R.

**Note:** Relays specified by catalog numbers (per above directions) are general use items controlled by catalog specifications. Relays to be controlled by customer drawings — or relays having requirements not covered in this publication — will be assigned special catalog numbers upon request.

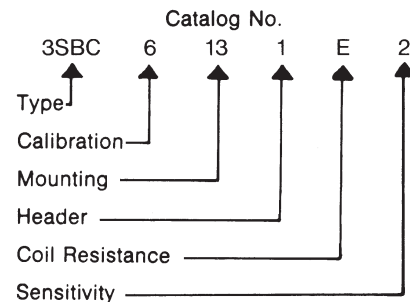

\* The part number example shown on this page is for catalog items. For a list of specific QPL part numbers, please see the index in Section 15.

**.150 Grid-space  
Long-life Relays  
Type 3SCC (2PDT)  
170 mW**

**Product Facts**

- 100,000,000 operations low-level signal loads
- RF designs available
- Low profile — 0.32 height
- Hermetic seal
- High reliability
- Performance tested

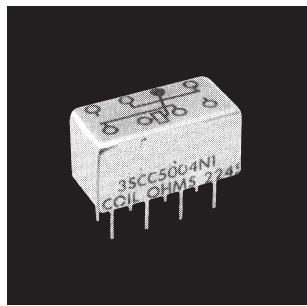

The .150 Grid relay, the smallest (.320 inches high) 2 Amp rated relay available in commercial and military qualified models, is now available in the long life version. Capable of over 100,000,000 mechanical operations at low level and signal load, the .150 Grid relay provides the simplicity of relays for circuit design, the low circuit resistance of precious metal contact systems, and the long life processing that has made CII relays the standard for quality and reliability.

**Electrical Characteristics**

**Contact Ratings —**  
 DC resistive — 2 amps at 28 volts (50,000 operations)  
 1 Amp @ 28 V (100,000 operations)  
 DC inductive — 0.5 amps at 28 volts, 200 mH  
 AC resistive — 0.5 amps at 115 volts  
 AC — 0.125 amps at 115 volts (case grounded)  
 Low-level — 50  $\mu$ A at 50 mV Peak AC or DC

**Contact Resistance —**  
 0.050 ohms max.; 0.150 ohms after life test

**Life —** 100,000 operations at rated loads listed; 1,000,000 operations at low-level loads

**Operating Characteristics**

**Operate Time —** 4 ms max.  
**Release Time —** 4 ms max.  
**Contact Bounce —** 1.5 ms  
**Dielectric Strength —**  
 500 volts rms at sea level;  
 350 volts rms at 70,000 feet and above  
**Insulation Resistance —** 1,000 megohm min. over temperature range

**Environmental Characteristics**

**Vibration —** 30G, to 3000 Hz  
**Shock —** 100 G at 11 ms  
**Temperature —** -40°C to +125°C

See page 1-44 for Mounting Forms, Terminals and Circuit Diagrams.

**Coil Table Type 3SCC (All Values DC)\* 2 PDT Relay – 170mW Sensitivity: (Code 1)**

Coil Code Letter	Coil Resistance @ 25C (ohms)	Voltage Calibrated, Code 5				Current Calibrated, Code 6			
		Suggested Source Volts†	Max. Operate Volts @25C	Release Voltage Range @ 25C		Max. Continuous Current @ 125C (mA)	Max. Operate Current @ 25C (mA)	Release Current Range @ 25C (mA)	
				Max.	Min.			Max.	Min.
A	44 $\pm$ 10%	3.5- 6.2	2.7	1.45	0.26	87.0	61.4	32.7	6.00
B	56 $\pm$ 10%	4.0- 7.0	3.1	1.6	0.3	77.0	55.4	28.6	5.30
D	140 $\pm$ 10%	6.4-12.0	4.9	2.6	0.5	50.3	35.0	18.5	3.60
E	210 $\pm$ 10%	8.0-16.0	5.9	3.2	0.6	40.0	28.0	15.4	2.80
L	650 $\pm$ 10%	13.6-24.0	10.5	5.6	1.0	22.9	16.2	8.6	1.54
K	1350 $\pm$ 10%	20.0-35.0	15.1	8.1	1.5	15.5	11.2	6.0	1.10
N	2245 $\pm$ 10%	26.0-46.0	19.5	10.5	1.9	12.0	8.7	4.7	0.84

\*Values listed are factory test and inspection data. User should allow for meter variations.

†Applicable over the operating temperature range in circulating air.

**Ordering Instructions**

**Example:** The relay selected in the example is a 2PDT .150-grid relay, current calibrated, end bracket mounting with 0.13-inch solder hook header, 210 ohms coil resistance, and 175 mW sensitivity. By choosing the proper code for each of these relay characteristics, the catalog number is 3SCC6131E1. The letter R following sensitivity code indicates relay received 5000 operation miss-test. Ex. 3SCC6131E1R.

**Note:** Relays specified by catalog numbers (per above directions) are general use items controlled by catalog specifications. Relays to be controlled by customer drawings — or relays having requirements not covered in this publication — will be assigned special catalog numbers upon request.

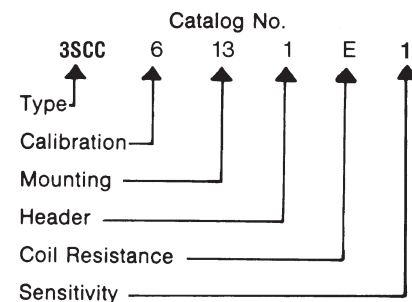

Double Pole, Electrically Held, 2 Amps and Less (Continued)

Mounting Forms  
(3SBC, 3SCC)

(Vibration note with each form is acceleration from 55 to 3000 Hz)

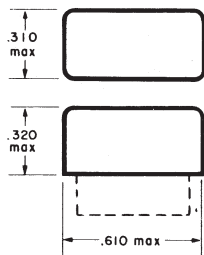

No Mount

Mounting Code	Vibration
00	30g

\*Assumes relay held securely by potting or other means

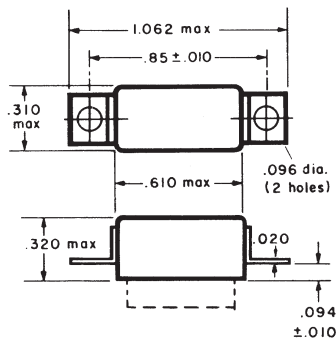

End Bracket

Mounting Code	Vibration
13	30g

All dimensions in inches

TOLERANCES (Unless otherwise specified)	
Hundredths	± 0.020
Thousandths	± 0.005

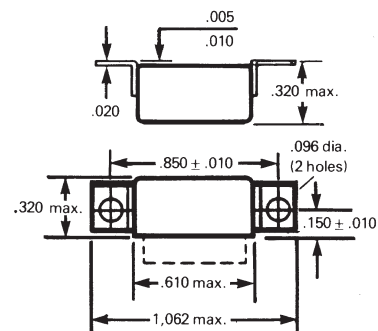

Side Bracket

Mounting Code	Vibration
25	30g

Header and Connection Diagrams

Header Types

TYPE	Z DIMENSION	HEADER CODE
Solder hook	0.13	1
Straight pin	0.12	8
Straight pin	0.19	4
Straight pin	0.25	5

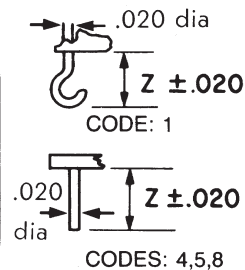

CODE 1, 5, & 6

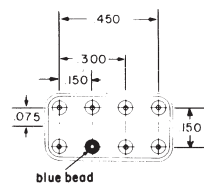

CODE 2

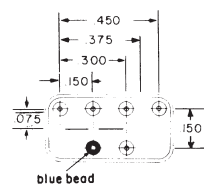

Terminal View

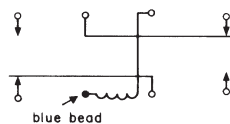

CODE 1

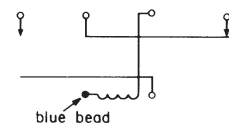

CODE 2

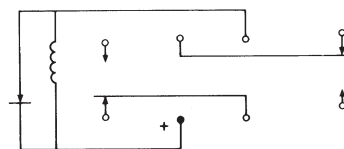

CODE 5  
SINGLE DIODE

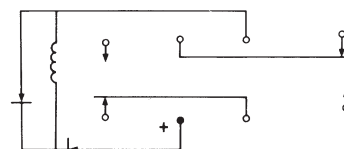

CODE 6  
DUAL DIODE

Double Pole, Electrically Held, 2 Amps and Less (Continued)

Crystal-Can Relays  
Type 3SAE (2PDT)

Product Facts

- Small lightweight crystal-can type
- 0.25 cubic inch, 0.60 ounces
- Power or low-level switching
- 20G to 2000 Hz vibration capability

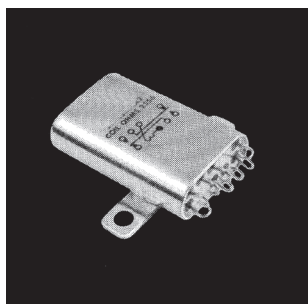

The TE Connectivity line of crystal-can relays is backed by years of experience and millions of relays operating in the field.

Electrical Characteristics

**Contact Ratings** —  
 DC resistive — 2 amps at 28 volts  
 DC inductive — 1 amp at 28 volts, L/R < .025  
 Low-level — 50 µA at 50 mV  
 Peak AC or DC  
 AC resistive — 1.0 amp at 115 volts, case not grounded  
 AC resistive — 0.25 amps at 115 volts, case grounded  
**Coil Resistance** —  
 0.050 ohms max. initial;  
 0.100 ohms max. after life test  
**Life** — 100,000 operations at rated load; 1,000,000 at low-level

Operating Characteristics

**Operate Time** — 6 ms max.  
**Release Time** — 5 ms max.  
**Contact Bounce** — 2.5 ms  
**Dielectric Strength** —  
 1,000 volts rms at sea level;  
 700 volts rms across contact gaps;  
 350 volts rms at 70,000 feet  
**Insulation Resistance** —  
 1,000 megohm min. except coil to case 500 min. at 125°C  
**Environmental Characteristics**  
**Vibration** — Depends upon mounting forms  
**Shock** — 50 G at 11 ms  
**Temperature** — -65°C to +125°C  
 See page 1-46 for Mounting Forms, Terminals and Circuit Diagrams.

Coil Table (All Values DC)\*  
Type 3SAE 330 mW Sensitivity: (Code 1)

Coil Code Letter	Voltage Calibrated, CODE: 5				
	Coil Resistance at 25C (Ohms)	Suggested Source Volts†	Maximum Operate Volts at 25C	Release Voltage at 25C	
				Max	Min
A	22 ± 10%	3.9- 5.9	2.7	1.4	0.29
B	34 ± 10%	4.8- 7.4	3.3	1.7	0.36
C	53 ± 10%	6.2- 9.2	4.2	2.2	0.46
D	92 ± 10%	8.0-12.0	5.4	2.8	0.60
E	146 ± 10%	10.2-15.0	6.9	3.6	0.76
F	215 ± 10%	12.3-18.5	8.3	4.3	0.92
H	342 ± 10%	15.4-23.0	10.4	5.4	1.16
K	552 ± 10%	20.0-29.5	13.5	7.0	1.50
L	814 ± 10%	25.0-36.0	16.9	8.8	1.88
M	1180 ± 10%	30.0-43.0	20.5	10.6	2.28
N	1278 ± 15%	31.0-41.5	21.3	11.0	2.36
P	1800 ± 15%	38.0-49.0	25.8	13.3	2.86
R	2530 ± 15%	43.0-58.5	29.0	15.0	3.22
S	2950 ± 15%	50.0-63.0	34.0	17.5	3.77
T	5000 ± 20%	62.0-75.0	41.8	21.6	4.64
V	5170 ± 20%	68.0-76.0	46.0	25.4	5.12

\*Values listed are factory test and inspection values. User should allow for meter variations.  
 †Applicable over the operating temperature range in circulating air.

Ordering Instructions

**Example:** The relay selected in this example is a 2PDT crystal-can relay, voltage calibrated, two-hole side bracket mounting solder hook header, 552 ohms coil resistance, and 330 mW sensitivity. By choos-

ing the proper code for each of these relay characteristics, the catalog number is identified as 3SAE5041K1. The letter R following sensitivity code indicates relay received 5000 operation miss-test. Ex. 3SAE5041K1R.

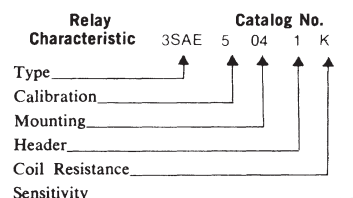

Double Pole, Electrically Held, 2 Amps and Less (Continued)

Mounting Forms (3SAE)

(Vibration note with each form is acceleration from 55 to 2000 Hz)

All dimensions in inches

TOLERANCES (unless otherwise specified)	
Hundredths	±0.020
Thousandths	±0.005

No Mount

Mounting Code	A Dim. (Max)	Vibration*	Relay Type
00	0.875	20g	3SAE

\* Assumes relay securely held by potting or other means.

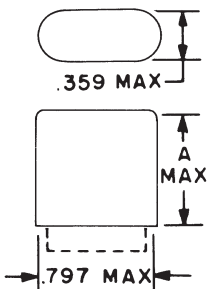

Flange Mount, 2 in-line holes

Mounting Code	A Dim. (Max)	X Dim.	Vibration	Relay Type
13	0.875	0.125	15g	3SAE
14	0.875	0.375	20g	3SAE

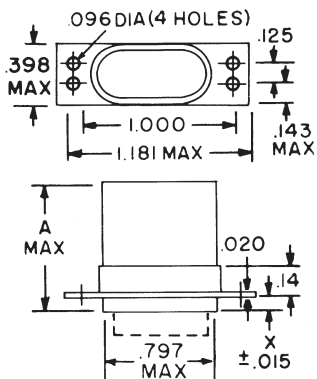
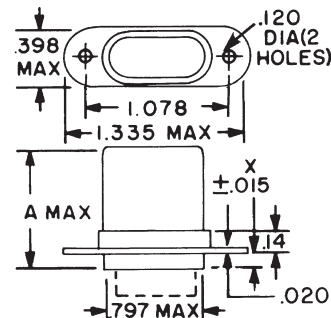

Four-hole Flange

Mounting Code	A Dim. (Max)	X Dim.	Vibration	Relay Type
01	0.875	0.125	15g	3SAE
02	0.875	0.375	20g	3SAE

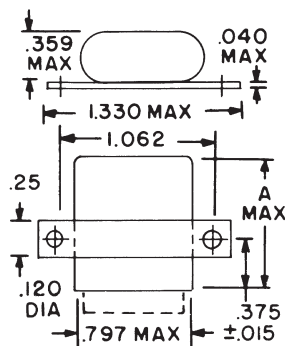

Two-hole Side Bracket

Mounting Code	A Dim. (Max)	Vibration	Relay Type
04	0.875	20g	3SAE

Side Studs

Mounting Code	A Dim. (Max)	C Dim.	X Dim.	Vibration	Relay Type
07	0.875	0.488	0.375	20g	3SAE
08	0.875	0.488	0.250	20g	3SAE

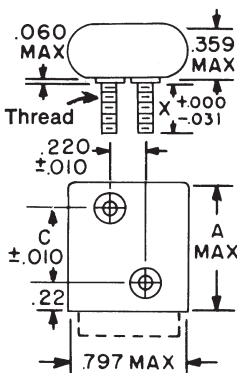

Top Studs

Mounting Code	A Dim. (Max)	X Dim.	Vibration	Relay Type
10	0.940	0.375	20g	3SAE
11	0.940	0.250	20g	3SAE

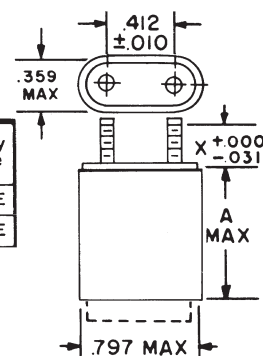

Header and Connection Diagrams

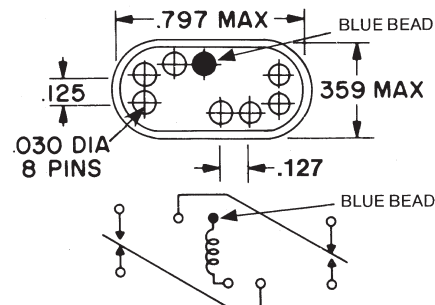

Header Types

Type	Z Dim.	Header Code
Solder hook	0.19	2
Straight pin (socket or PCB type)	0.19	4
Straight pin	2.99	8

CODE: 1

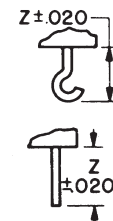

CODES: 4, 8

Double Pole, Magnetic Latching, 2 Amps and Less

LS

LS

Magnetic Latching Half Size High Performance Relay

DESIGNED to MIL-R-39016/45

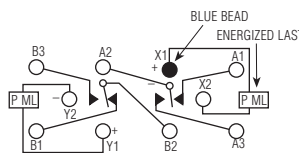
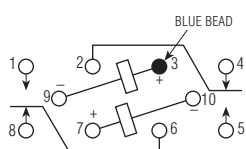
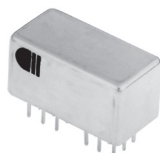

Terminal View

**Standard Schematic** Contacts will switch from the indicated position when either coil is energized with polarity as shown.

**MIL-R-39016/45 SCHEMATIC** Contacts will switch from the indicated position when either coil is energized with polarity as shown.

Product Facts

- Hermetically sealed
- Up to 2 amps switching
- High shock & vibration ratings
- Optional terminals & mounting styles
- Latching design

Electrical Characteristics

**Contact Arrangement** — 2 Form C (DPDT)

**Contact Material** —

Stationary — Gold plated hardened silver alloy

Moveable — Gold plated hardened silver alloy

**Contact Resistance** —

Before Life — 50 milliohms max.

(measured at 10 mA @ 6 Vdc)

After Life — 100 milliohms max.

(measured @ 2 A @ 28 Vdc)

**Mechanical Life Expectancy** —

1 million operations min.

**Coil Voltage** — 5 to 48 Vdc

**Coil Power** — 1.0 watts max.

**Duty Cycle** — Continuous

**Pick-up Voltage** — Approximately

50% of nominal coil voltage

**Pick-up Sensitivity** — 170 mW

Contact Ratings

Contact Load	Type	Operations Min.
2 A @ 28 Vdc	Resistive	100,000
0.3 A @ 115 Vac, 60 Hz & 400 Hz	Resistive	100,000
0.75 A @ 28 Vdc	Inductive (200mH)	100,000
0.1 A @ 28 Vdc	Intermediate	50,000
0.160 A @ 28 Vdc	Lamp	100,000
30 $\mu$ A @ 50 mVdc	Low Level	1,000,000

RF Performance

Frequency (MHz)	RF Losses (dB)	VSWR	Isolation (dB)
100	0.1	1.15:1	38
500	0.3	1.19:1	31
1000	0.6	1.32:1	45

**Double Pole, Magnetic Latching, 2 Amps and Less** (Continued)

**LS (Continued)**

**Operating Characteristics**

**Timing** —  
Set-Reset Time — 5.0 ms max.  
**Contact Bounce** —  
2.0 ms max.  
**Dielectric Withstanding Voltage** —  
Between Open Contacts —  
500 Vrms 60 Hz  
Between Adjacent Contacts —  
1000 Vrms 60 Hz  
Between Contacts and Coil —  
1000 Vrms 60 Hz  
**Insulation Resistance** —  
10,000 megohms min. @ 500 Vdc

**Environmental Characteristics**

**Temperature Range** —  
-65°C to +125°C  
**Weight** — .46 oz (13 gms) max.  
**Vibration Resistance** —  
Standard — 20 G's, 10 to 2,000 Hz  
QPL Equiv. — 30 G's, 10 to 2,500 Hz  
**Shock Resistance** —  
100 G's, 6 ±1 ms  
**QPL Equivalent** —  
MIL-R-39016/45

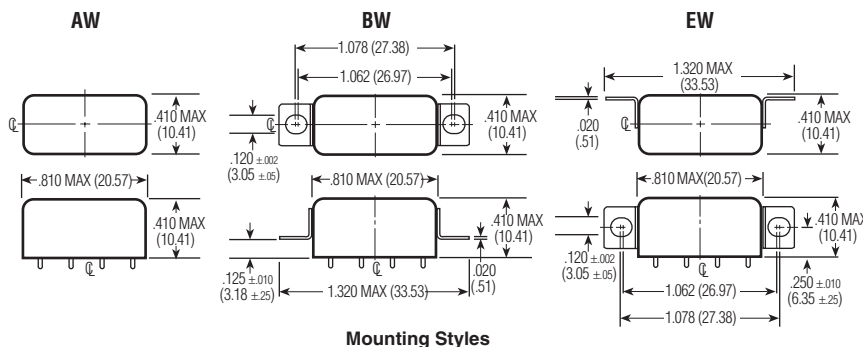
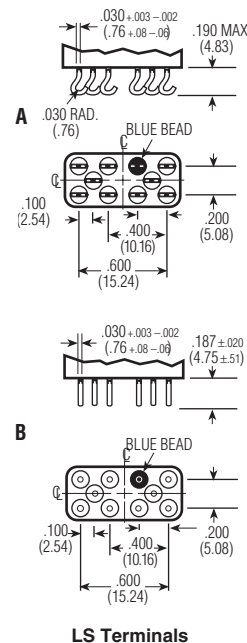

**Standard Coil Data**

Nom. Coil Voltage (Vdc)	Coil Resistance in Ohms ±10% @ 25°C	Pickup Voltage Vdc (Max.) @ 25°C	Pickup Voltage Vdc (Max.) @ 125°C	Pickup Voltage Vdc (Min.) @ 25°C	Pickup Voltage Vdc (Min.) @ -65°C	Nom. Coil Power (mW) @ 25°C	Max. Coil Voltage	Coil Desig.
5.0	45	2.7	3.8	1.6	1.0	556	6.7	5
6.0	63	3.25	4.5	2.0	1.3	571	8.0	6
12.0	254	6.5	9.0	4.0	2.6	567	16.0	12
26.5	1,000	13.0	18.0	8.0	5.2	702	32.0	24
48.0	3,800	26.0	36.0	16.0	10.4	606	64.0	48

**Ordering Instructions**

Catalog-selected Relays: The catalog number is derived by choosing the proper CODE for each of the six relay characteristics in the order in which the codes are listed.

**Specifying a Part Number Example:**

**Type**                      **Mountings**                      **Contacts**                      **Coils**                      **Terminals**  
 LS                              BW-                              2C-                              24                              B

**Double Pole, Magnetic Latching, 2 Amps and Less** (Continued)

**Magnetic Latching, Grid Space, Relay Type 3SDM (2PDT)**

**Product Facts**

- Suitable for pulse operation
- No hang up feature
- MIL-R-39016 type
- Special contact and coil wiring available

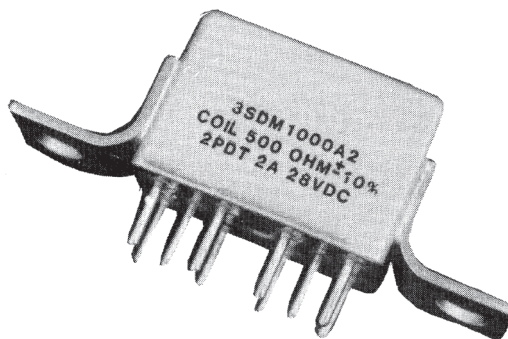

This magnetic latching relay maintains the high reliability attributes of the aerospace proven CII 3SAM relay family. By reducing the size of the coil and maintaining the contact system of the 3SAM, we can now offer a smaller 2 amp rated magnetic latching relay. The pulse operation can provide multiple hundred thousand operations in power saving circuits. The on or off

circuits are maintained using no power until there is a need to switch the contacts. Suitable for matrix switches or relay trees, these versatile relays have contact systems capable of reliability switching high power or very low level signals in the same package. The relay's unique circuit prevents it from ever hanging up in an off-center or neutral position.

**Electrical Characteristics**

**Contact Ratings** —  
 DC resistive — 2 amps at 28 volts  
 Low-level — 50  $\mu$ A at 50 mV DC or peak AC

**Contact Resistance** —  
 0.050 ohms initial;  
 0.100 ohms after life test (High level)  
 0.150 ohms after life test (Low level)

**Life** —  
 100,000 operations at rated load;  
 1,000,000 operations at low-level

**Operating Characteristics**

**Operate Time** — 4 ms

**Reset Time** — 4 ms

**Contact Bounce** — 2 ms

**Dielectric Strength** —  
 1,000 volts at sea level;  
 500 volts across contact gap and  
 500 volts coil to case

**Insulation Resistance** —  
 1,000 megohms min.

**Environmental Characteristics**

**Vibration** —  
 Sine — 30G; 55 to 3000 Hz  
 Random — 0.4 G<sup>2</sup>/Hz; 100 to 1,000 Hz

**Shock** — 150 G at 11 ms, half-sine wave

**Temperature** — -65°C to +125°C

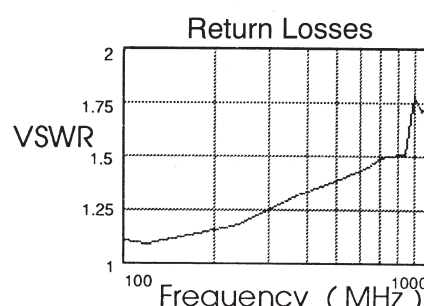
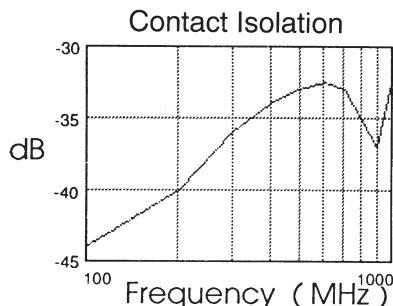
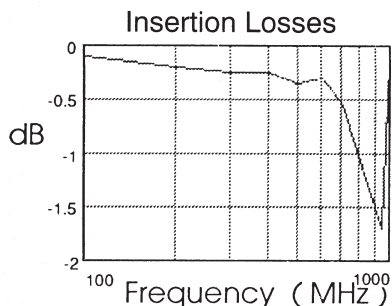

Double Pole, Magnetic Latching, 2 Amps and Less (Continued)

Mounting Forms (3SDM)

Mounting Code	X Dim.
10	0.250
11	0.375

Mounting Code	X Dim.
13	0.125
14	0.250

Mounting Code	X Dim.
53	

Mounting Code	X Dim.
04	

**Coil Resistance (All Values are DC): Voltage Calibrated - Code 5**

Coil Resistance Code	Coil Voltage Rated	Coil Voltage Maximum	Coil Res. Ohms @ 20°C	Max. Set-Reset VDC @ 20°C	Max. Set-Reset VDC @ 125°C
C	6	7	31 +/- 10%	3.0	5.3
E	12	14	124 +/- 10%	6.0	10.5
H	24	28	500 +/- 10%	12.0	21.0

Values are factory test and inspection values. User should allow for meter variations.

Header:

Type	Z Dimensions	Header Code
Straight Pin (socket or PCB Type)	0.19 +/- .020	4
Solder Hook	0.16 +/- .020	2

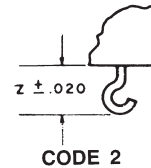
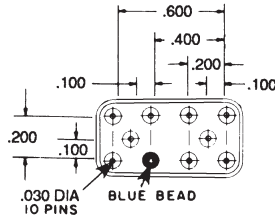

CODE 4

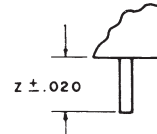

Sensitivity and Modification: 290 mW Sensitivity

Sensitivity Code	Modification (see connection diagrams at right)
1	No Diode
5	Single Diode

(Terminal View) (+ on blue bead closes as shown)

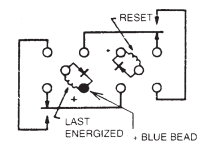
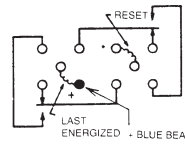

Ordering Instructions

Type 3SDM relays can be ordered by specifying the correct catalog number. This number is derived by choosing the proper CODE for each of the six relay characteristics in the order in which the codes are listed in the example. The letter R following the sensitivity code indicates relay received 5,000 operations miss-test.

**Example:** The relay selected is a 2PDT magnetic-latching relay, voltage calibrated, 2-hole end bracket mount, solder hook header, 500 ohm coil, and 290 mW sensitivity. **3SDM5132H1**

Relay Characteristic Catalog Number

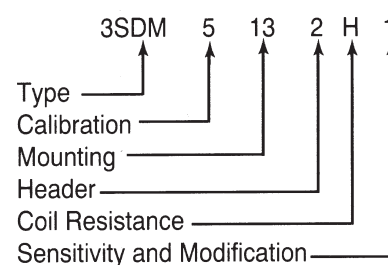

Double Pole, Magnetic Latching, 2 Amps and Less (Continued)

Magnetic Latching, Grid-space, Relays Type 3SAM (2PDT)

Product Facts

- Special shock designs up to 700 G, 1 ms
- Suitable for pulse operation
- No hang up feature on low power pulses
- Qualified to MIL-R-39016/32
- Special wiring is available

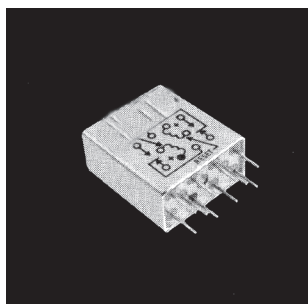

This relay has “memory” in that the contact positions do not change when coil power is removed. Switching is accomplished by applying power to the applicable coil (dual coil) or with the applicable polarity (single coil). The low switching power requirements are further enhanced by its ability to operate from capacitor discharge or other pulses or through its own contacts for batteries or similarly limited supplies.

Electrical Characteristics

**Contact Ratings** —  
 DC resistive — 2 amps at 28 volts  
 DC inductive — 0.5 amps at 28 volts, 200 mH  
 AC resistive — 1 amp at 115 volts (single coil), case not grounded  
 AC resistive — 0.25 amps at 115 volts (dual coil), case not grounded  
 Low-level — 50  $\mu$ A at 50 mV  
 Peak AC or DC

**Contact Resistance** —  
 0.050 ohms initial;  
 0.100 ohms after life test

**Life** —  
 100,000 operations at rated load;  
 1,000,000 at low-level

Operating Characteristics

**Operate Time** — 4 ms  
**Release Time** — 4 ms  
**Contact Bounce** — 2 ms  
**Dielectric Strength** —  
 1,000 volts rms at sea level;  
 700 volts rms across contact gap  
**Insulation Resistance** —  
 1,000 megohm min.

Environmental Characteristics

**Vibration** — 30 G, to 3,000 Hz  
**Shock** — 150 G at 11 ms  
**Temperature** — -65°C to +125°C

See page 1-52 for Mounting Forms, Terminals and Circuit Diagrams.

Coil Table (All Values DC) Single Coil 50 mW Sensitivity: (Code: 1)

Coil Code Letter	Current Calibrated, CODE: 6		
	Coil Resistance @25C (Ohms)	Max Operate and Reset Current (mA) †	Suggested Source Voltage ‡
A	16.4 ± 10%	55.2	1.8-4.8
B	40 ± 10%	35.3	2.7-7.5
C	96 ± 10%	22.8	4.2-11.0
D	164 ± 10%	17.4	5.5-15.0
E	260 ± 10%	13.9	7.0-19.0
F	400 ± 10%	11.2	8.5-23.0
H	600 ± 10%	9.2	11.0-29.0
K	960 ± 10%	7.2	13.0-37.0
L	1350 ± 10%	6.1	16.0-43.0
M	1950 ± 10%	5.1	19.0-52.0
N	3000 ± 15%	4.1	25.0-64.0
P	4800 ± 15%	3.3	32.0-81.0
R	8200 ± 20%	2.5	43.0-91.0

† Applicable over the operating temperature range in circulating air.  
 ‡ Initial or inspection value. Allow 20% increase in value of maximum pickup during rated life.

Coil Table (All Values DC) Dual Coil 75 mW Sensitivity: (Code: 2)

Coil Code Letter	Current Calibrated, CODE: 6		
	Coil Resistance @25C For Each Coil (Ohms)	Max† Operate Current For Each Coil (mA)	Suggested Source Voltage For Each Coil‡
A	8.2 ± 10%	95.8	1.5-2.6
B	20 ± 10%	61.2	2.3-4.1
C	48 ± 10%	39.5	3.6-6.3
D	82 ± 10%	30.2	4.7-8.3
E	130 ± 10%	24.0	6.0-10.0
F	200 ± 10%	19.4	7.4-13.0
H	300 ± 10%	15.8	9.0-16.0
K	480 ± 10%	12.5	12.0-20.0
L	675 ± 10%	10.6	14.0-24.0
M	975 ± 10%	8.8	16.0-29.0
N	1500 ± 15%	7.1	21.0-35.0
P	2400 ± 15%	5.6	27.0-44.0
R	4100 ± 20%	4.3	37.0-55.0

† Applicable over the operating temperature range in circulating air.  
 ‡ Initial or inspection value. Allow 20% increase in value of maximum pickup during rated life.

Ordering Instructions

**Example:** The relay selected in this example is a 2PDT magnetic latching relay, current calibrated, four-hole end bracket mounting, solder hook header, 1500 ohms coil resistance, and 75 mW sensitivity. By choosing the proper code for each

of these relay characteristics, the catalog number is identified as 3SAM6014N2. The letter R following sensitivity code indicates relay received 5000 operation miss-test. Ex. 3SAM6014N2R.

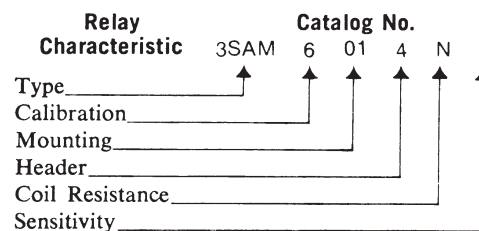

\* The part number example shown on this page is for catalog items. For a list of specific QPL part numbers, please see the index in Section 15.

Double Pole, Magnetic Latching, 2 Amps and Less (Continued)

Mounting Forms (3SAM)

(Vibration note with each form is acceleration from 55 to 3000 Hz)

No Mount

Mounting Code	Vibration*
00	30g

\* Assumes relay securely held by potting or other means.

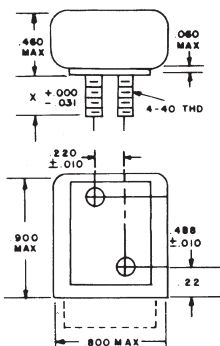
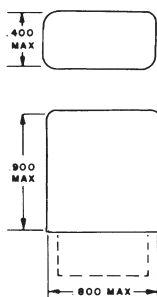

Two-hole End Bracket

Mounting Code	X Dim.	Vibration
13	0.125	30g
14	0.250	30g
15	0.450	30g

Side Studs

Mounting Code	X Dim.	Vibration
07	0.250	30g
08	0.375	30g

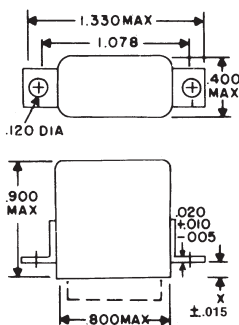

All dimensions in inches

TOLERANCES (unless otherwise specified)	
Hundredths	±0.020
Thousandths	±0.005

Top Studs

Mounting Code	X Dim.	Vibration
10	0.250	30g
11	0.375	30g

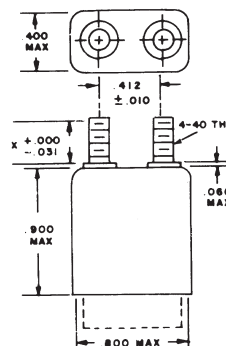

Four-hole End Bracket

Mounting Code	X Dim.	Vibration
01	0.125	30g
02	0.250	30g
03	0.450	30g

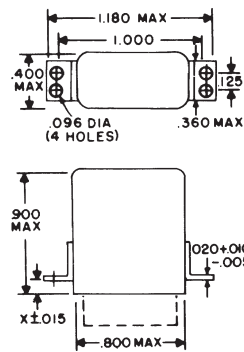

Four-hole Side Bracket

Mounting Code	Vibration
06	30g

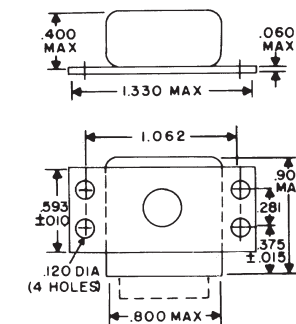

Header and Connection Diagrams

Single Coil

(Terminal View)

(+ on blue bead closes as shown)

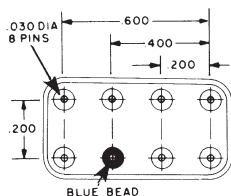

Dual Coil

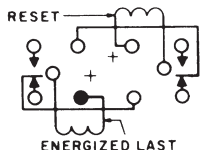
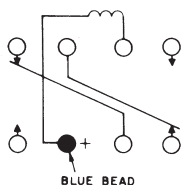
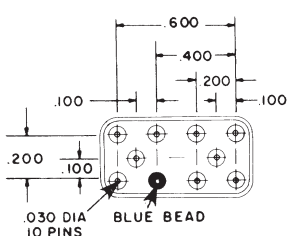

Header Types

Type	Z Dimension	Header Code	
		Single	Dual
Solder hook	0.16	1	4
Straight pin (socket or PCB type)	0.19	2	5

CODES: 2, 5

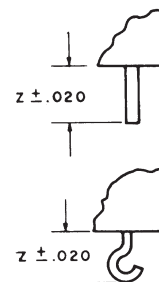

CODES: 1, 4

Four Pole, Electrically Held, 2 Amps and Less

SR

SR

Four Pole Half Size  
High Performance Relay

Qualified to  
MIL-R-39016/40

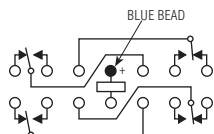

Terminal View

Product Facts

- Hermetically sealed
- Up to 2 amps switching
- High shock & vibration ratings
- Optional terminals & mounting styles
- 4 form C Hi-density design

Electrical Characteristics

Contact Arrangement —

4 Form C (4PDT)

Contact Material —

Stationary —  
Gold plated hardened silver alloy  
Moveable —  
Gold plated hardened silver alloy

Contact Resistance —

Before Life — 50 milliohms max.  
(measured at 10 mA @ 6 Vdc)  
After Life — 100 milliohms max.  
(measured @ 2 A @ 28 Vdc)

Mechanical Life Expectancy —

1 million operations min.

Coil Voltage — 6 to 26.5 Vdc

Coil Power — 2.6 watts max. @ 25°C

Duty Cycle — Continuous

Pick-up Voltage — Approximately  
50% of nominal coil voltage

Pick-up Sensitivity — 475 mW

Contact Ratings

Contact Load	Type	Operations Min.
2 A @ 28 Vdc	Resistive	100,000
0.3 A @ 115 Vac, 60 Hz & 400 Hz	Resistive	100,000
0.75 A @ 28 Vdc	Inductive (200mH)	100,000
0.1 A @ 28 Vdc	Intermediate	50,000
0.2 A @ 28 Vdc	Lamp	100,000
10 µA @ 50 mV	Low Level	1,000,000

Four Pole, Electrically Held, 2 Amps and Less (Continued)

SR (Continued)

Operating Characteristics

**Timing** —  
 Operate Time — 5.0 ms max.  
 Release Time — 5.0 ms max.  
**Contact Bounce** — 5 ms max  
**Dielectric Withstanding Voltage** —  
 Between Open Contacts —  
 350 Vrms 60 Hz  
 Between Adjacent Contacts —  
 500 Vrms 60 Hz  
 Between Contacts & Coil —  
 500 Vrms 60 Hz  
**Insulation Resistance** —  
 1,000 megohms min. @ 500 Vdc

Environmental Characteristics

**Temperature Range** —  
 -65°C to +125°C  
**Weight** —  
 0.28 oz. (7.8 grms)  
**Vibration Resistance** —  
 15 G's, 10 to 2,000 Hz  
**Shock Resistance** —  
 100 G's, 6 ±1 ms  
**QPL Approval** —  
 MIL-R-39016/40

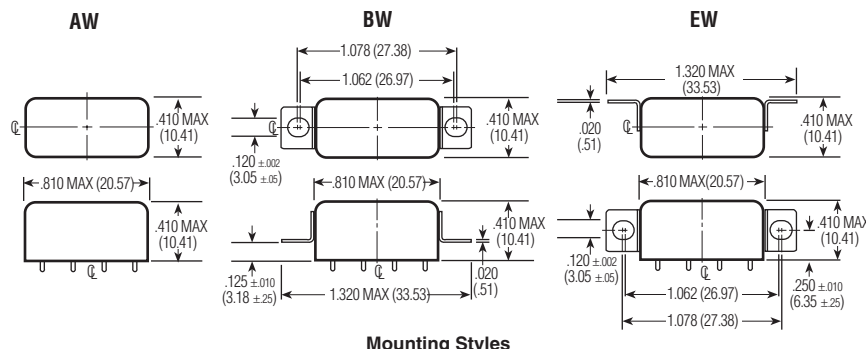
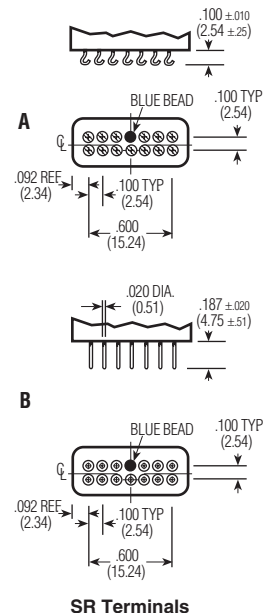

Standard Coil Data

Nom. Coil Voltage (Vdc)	Coil Resistance in Ohms ±10% @ 25°C	Pickup Voltage Vdc (Max.) @ 25°C	Pickup Voltage Vdc (Max.) @ 125°C	Drop-out Voltage Vdc (Min.) @ 25°C	Drop-out Voltage Vdc (Min.) @ -65°C	Nom. Coil Power (W) @ 25°C	Max. Coil Voltage	Coil Desig.
5.0	20	2.75	3.8	0.35	0.23	1.25	6.0	5
6.0	25	3.5	4.5	0.45	0.3	1.44	8.0	6
12.0	100	6.5	9.0	0.9	0.6	1.44	15.0	12
26.5	390	14.0	18.0	1.8	1.2	1.8	32.0	24

Specifying a Part Number Example:

**Type**                      **Mountings**                      **Contacts**                      **Coils**                      **Terminals**  
 SR                              BW-                              4C-                              24                              B

\* The part number example shown on this page is for catalog items. For a list of specific QPL part numbers, please see the index in Section 15.

Four Pole, Electrically Held, 2 Amps and Less (Continued)

.150 Grid-space Relays  
Type 3SBH (4PDT)

Product Facts

- Low profile... only 0.32 inches high
- Long life version available
- Qualified to MIL-R-39016/14

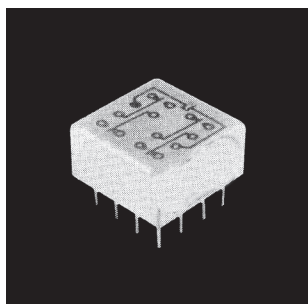

This .150 four pole double throw Grid-space relay is the companion to the two pole 3SBC type shown on page 1-41. It also features the same .150 inch pin spacing that allows you to insert the relay with no intermediate pin spreaders. There is adequate clearance for conductors to reach all pins. It is a very compact 4 pole double throw 2 ampere relay.

Electrical Characteristics

**Contact Ratings** —  
 DC resistive — 2 amps at 28 volts  
 DC inductive — 0.5 amps at 28 volts, 200 mH  
 AC resistive — 0.5 amps at 115 volts, 400 or 60 Hz (enclosure isolated from ground, or enclosure and movable contact at same potential)  
 AC — 0.125 amps at 115 volts (enclosure at line potential with respect to movable contact)  
 Low-level — low-level operation at 50 millivolts, 30  $\mu$ A, 33 ohm miss level

**Contact Resistance** —  
 0.050 ohms max.;  
 0.150 ohms after life test

**Life** —  
 100,000 operations at rated loads listed;  
 1,000,000 operations at low-level loads

Operating Characteristics

**Operate Time** — 4 ms max.  
**Release Time** — 4 ms max.  
**Contact Bounce** — 1.5 ms  
**Dielectric Strength** —  
 500 volts rms at sea level;  
 350 volts rms at 70,000 feet  
**Insulation Resistance** —  
 1,000 megohms min. over temperature range

**Environmental Characteristics**  
**Vibration** — 30 G, to 3,000 Hz  
**Shock** — 100 G at 11 ms  
**Temperature** — -65°C to +125°C

See page 1-57 for Mounting Forms, Terminals and Circuit Diagrams.

Coil Table (All Values DC)\* Type 3SBH, 4 Pole Relay — 250 mW Sensitivity: (Code 1)

SENSITIVITY CODE: 1					
Coil Code Letter	Coil Resistance at 25C ohms	Voltage Calibrated, Code: 5			
		Suggested Source Volts†	Maximum Operate Volts at 25C	Release Voltage Range at 25C	
				Max.	Min.
B	28 $\pm$ 10%	4.0- 7.0	2.7	1.6	0.3
D	73 $\pm$ 10%	6.0-11.0	4.2	2.5	0.4
E	115 $\pm$ 10%	8.0-14.0	5.4	3.2	0.6
G	280 $\pm$ 10%	12 -22.0	8.4	5.0	0.8
H	430 $\pm$ 10%	15 -26.0	10.3	6.0	1.0
K	720 $\pm$ 10%	20 -35.0	13.5	8.1	1.5
N	1040 $\pm$ 10%	26 -46.0	17.5	10.5	1.9

\*Values listed are factory test and inspection values. User should allow for meter variations.  
 †Applicable over the operating temperature range in circulating air.

Ordering Instructions

**Catalog-selected Relays:** The catalog number is derived by choosing the proper CODE for each of the six relay characteristics in the order in which the codes are listed.

**Example:** The relay selected in this example is a 4PDT .150-grid relay, voltage calibrated, end bracket mounting, 0.13 inch solder hook header, 720 ohms coil resistance, and 250 mW sensitivity. By choosing the proper code for each of these relay characteristics, the catalog number is identified as 3SBH5131K1. The letter R following sensitivity code indicates relay received 5000 operation miss-test. Ex. 3SBH5131K1R.

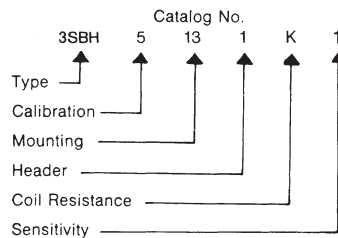

\* The part number example shown on this page is for catalog items. For a list of specific QPL part numbers, please see the index in Section 15.

Four Pole, Electrically Held, 2 Amps and Less (Continued)

.150 Grid-space Hybrid Relays  
Type 3SBH (4PDT)

Product Facts

- Low profile... only 0.32 inches high
- Long life version available
- Qualified to MIL-R-39016/53 & 54

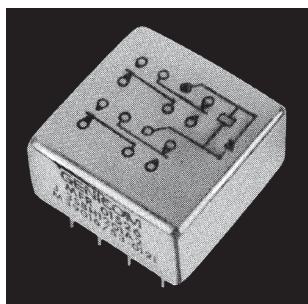

The 4PDT .150 Grid-space hybrid relays are advanced designs of the standard high reliability 4PDT .150 Grid-space relays. In the single diode version, the relay coil-back electromotive force is suppressed to prevent circuit/component damage. With the dual diode version, a steering diode is added to the coil circuit, along with the suppression diode. This

steering diode prevents operation of the relay by reverse polarity voltages and protects the suppression diode. The single diode version is qualified to MIL-R-39016/53 and the dual diode is qualified to MIL-R-39016/54.

Electrical Characteristics

**Contact Ratings** —  
DC resistive — 2 amps at 28 volts  
DC inductive — 0.5 amps at 28 volts, 200 mH  
AC resistive — 0.5 amps at 115 volts, 400 or 60 Hz (enclosure isolated from ground, or enclosure and movable contact at same potential)  
AC — 0.125 amps at 115 volts (enclosure at line potential with respect to movable contact)  
Low-level — 50  $\mu$ A at 50mV  
**Contact Resistance** —  
0.050 ohms max.;  
0.150 ohms after life test  
**Life** — 100,000 operations at rated loads listed; 1,000,000 operations at low-level loads

Operating Characteristics

**Operate Time** — 4 ms max.  
**Release Time** — 6 ms max.  
**Contact Bounce** — 2.0 ms  
**Dielectric Strength (Note 1)** —  
500 volts rms at sea level;  
350 volts rms at 70,000 feet  
**Insulation Resistance (Note 1)** —  
1,000 megohms min. over temperature range

Semiconductor Characteristics at 25°C

**Max. Negative Transient** — 1 volt  
**Breakdown Voltage** —  
100 Vdc @ 10  $\mu$ A min.  
**Max. Leakage Current** —  
1  $\mu$ A @ 50 Vdc

**Note 1:** Tests for dielectric withstanding voltage and insulation resistance should be made with "coil terminals" shorted together to avoid unnecessary electrical stress to semiconductor elements.

See page 1-57 for Mounting Forms, Terminals and Circuit Diagrams.

Coil Table (All Values DC)\* Type 3SBH, 4 Pole Relay — 250 mW Sensitivity:  
(Code 5 single diode, Code 6 dual diodes)

Single Diode		SENSITIVITY CODE: 5			
Coil Code Letter	Coil Resistance at 25C ohms	Voltage Calibrated, Code: 5			
		Suggested Source Volts†	Maximum Operate Volts at 25C	Release Voltage Range at 25C	
				Max.	Min.
B	28 $\pm$ 10%	4.0- 7.0	2.7	1.6	0.3
D	73 $\pm$ 10%	6.0-11.0	4.2	2.5	0.4
E	115 $\pm$ 10%	8.0-14.0	5.4	3.2	0.6
G	280 $\pm$ 10%	12 -22.0	8.4	5.0	0.8
H	430 $\pm$ 10%	15 -26.0	10.3	6.0	1.0
K	720 $\pm$ 10%	20 -35.0	13.5	8.1	1.5
N	1040 $\pm$ 10%	26 -46.0	17.5	10.5	1.9
Dual Diode		SENSITIVITY CODE: 6			
B	28 $\pm$ 10%	4.0- 7.0	3.7	2.3	0.5
D	73 $\pm$ 10%	6.0-11.0	5.2	3.2	0.6
E	115 $\pm$ 10%	8.0-14.0	6.4	3.9	0.8
G	280 $\pm$ 10%	12.0-22.0	9.4	5.7	1.0
H	430 $\pm$ 10%	15 -26.0	11.3	6.7	1.2
K	720 $\pm$ 10%	20 -35.0	14.5	8.8	1.7
N	1040 $\pm$ 10%	26 -46.0	18.1	11.1	2.1

\*Values listed are factory test and inspection values. User should allow for meter variations.

†Applicable over the operating temperature range in circulating air.

Four Pole, Electrically Held, 2 Amps and Less (Continued)

No Mount

Mounting Code	Vibration*
00	30g

\*Assumes relay held securely by potting or other means.

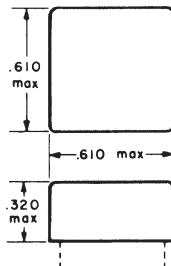

End Bracket

Mounting Code	Vibration
13	30g

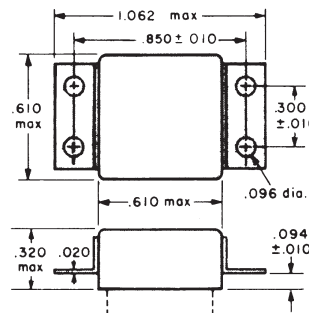

Header Types

Type	Z Dimension	Header Code
Solder hook	0.13	1
Straight pin	0.12	8
Straight pin socket or PCB type)	0.19	4
Straight pin	0.25	5

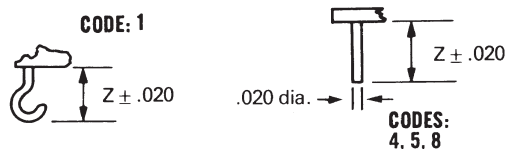

All dimensions in inches

TOLERANCES (Unless otherwise specified)	
Hundredths	±0.020
Thousandths	±0.005

Header and Connection Diagrams

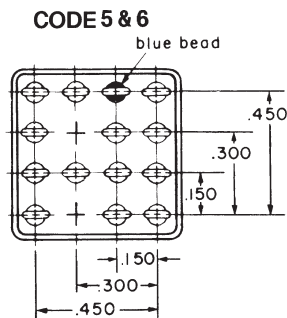
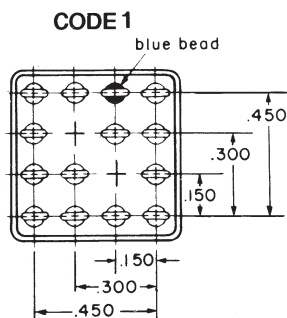
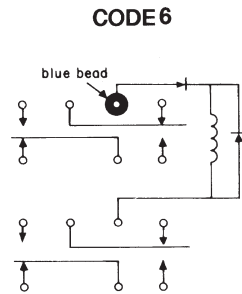
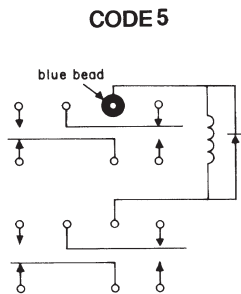
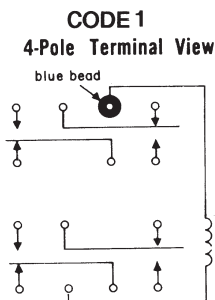

Terminals .020 dia

Ordering Instructions

**Catalog-selected Relays:** The catalog number is derived by choosing the proper CODE for each of the six relay characteristics in the order in which the codes are listed.

**Example:** The relay selected in this example is a 4PDT .150-grid relay, voltage calibrated, end bracket mounting, 0.13 inch solder hook header, 720 ohms coil resistance, and 250 mW sensitivity. By choosing the proper code for each of these relay characteristics, the catalog number is identified as 3SBH5131K5. The letter R following sensitivity code indicates relay received 5000 operation miss-test. Ex. 3SBH5131K5R.

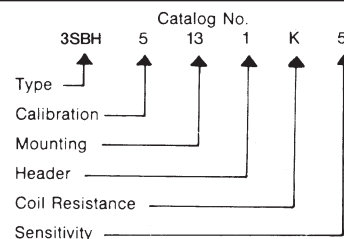

\* The part number example shown on this page is for catalog items. For a list of specific QPL part numbers, please see the index in Section 15.

**Four Pole, Electrically Held, 2 Amps and Less** (Continued)

**Long-life .150 Grid-space Relays**  
**100,000,000 Operations At Low Levels**  
**Type 3SDH (4PDT)**

**Product Facts**

- Long life at low level or signal loads
- Low profile... only 0.32 inches high

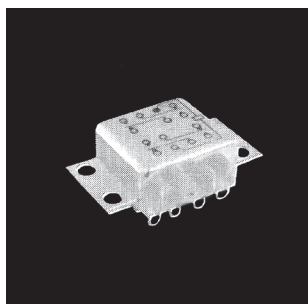

The 3SDH relay is designed for 100,000,000 operations at low levels. It is a four pole double throw Grid-space relay. The 0.150 inch pin spacing allows the user to insert the relay with no intermediate pin spreaders. There is adequate clearance for conductor to reach all pins.

**Electrical Characteristics**

**Contact Ratings** —  
 DC resistive — 2 amps at 28 volts, (DC 100,000 operations)  
 DC inductive — 0.3 amp at 28 volts, (L/R not greater than 0.008)  
 AC resistive — 0.5 amp at 115 volts, 400 or 60 Hz (enclosure isolated from ground, or enclosure and movable contact at same potential)  
 AC resistive — 0.125 amp at 115 volts (enclosure at line potential with respect to movable contact)  
 Low-level — 50  $\mu$ A at 50 mV  
 Peak AC or DC

**Contact Resistance** —  
 0.050 ohms max.;  
 0.150 ohms after life test

**Life** — 100,000 operations at rated loads listed; 100,000,000 operations at low-level loads

**Operating Characteristics**

**Operate Time @ +25°C** —  
 4 ms max.

**Release Time @ +25°C** —  
 4 ms max.

**Contact Bounce @ +25°C** — 1.5 ms

**Dielectric Strength** —  
 500 volts rms at sea level;  
 350 volts rms at 70,000 feet

**Insulation Resistance** —  
 1,000 megohms min. over temperature range

**Environmental Characteristics**

**Vibration** — 30 G, to 3,000 Hz

**Shock** — 100 G at 11 ms

**Temperature** — -40°C to +125°C

See page 1-59 for Mounting Forms, Terminals and Circuit Diagrams.

**Coil Table (All Values DC)\*Type 3SDH, 4 Pole Relay—210mW Sensitivity: (Code 1)**

SENSITIVITY CODE: 1					
Coil Code Letter	Coil Resistance at 25C ohms	Voltage Calibrated, Code: 5			
		Suggested Source Volts†	Maximum Operate Volts at 25C	Release Voltage Range at 25C	
				Max.	Min.
B	28 $\pm$ 10%	4.0- 7.0	3.0	1.6	0.3
D	73 $\pm$ 10%	6.0-11.0	4.8	2.5	0.4
E	115 $\pm$ 10%	8.0-14.0	5.9	3.2	0.6
G	280 $\pm$ 10%	12 -22.0	9.3	5.0	0.8
H	430 $\pm$ 10%	15 -26.0	11.5	6.0	1.0
K	720 $\pm$ 10%	20 -35.0	14.9	8.1	1.5
N	1040 $\pm$ 10%	26 -46.0	17.9	10.5	1.9

\*Values listed are factory test and inspection values. User should allow for meter variations.

†Applicable over the operating temperature range in circulating air.

Four Pole, Electrically Held, 2 Amps and Less (Continued)

No Mount

Mounting Code	Vibration*
00	30g

\*Assumes relay held securely by potting or other means.

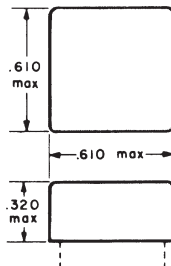

End Bracket

Mounting Code	Vibration
13	30g

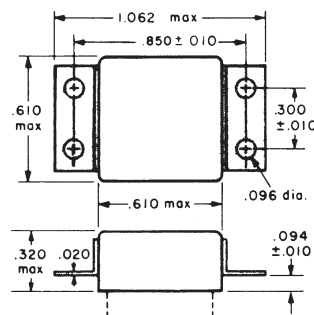

Header Types

Type	Z Dimension	Header Code
Solder hook	0.13	1
Straight pin	0.12	8
Straight pin socket or PCB type)	0.19	4
Straight pin	0.25	5

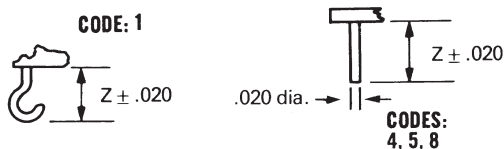

All dimensions in inches

TOLERANCES (Unless otherwise specified)	
Hundredths	±0.020
Thousandths	±0.005

Header and Connection Diagrams

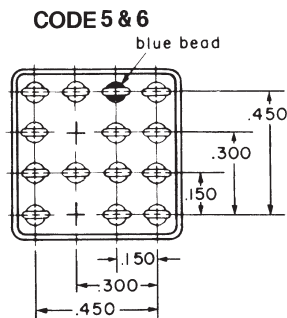
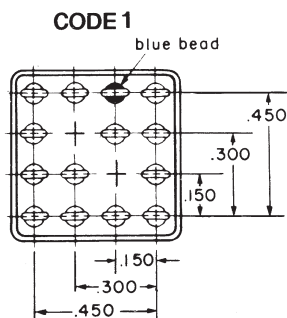
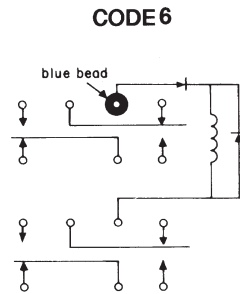
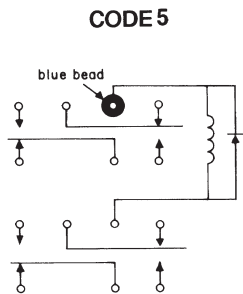
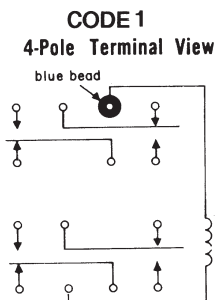

Terminals .020 dia

Ordering Instructions

**Catalog-selected Relays:** The catalog number is derived by choosing the proper CODE for each of the six relay characteristics in the order in which the codes are listed.

**Example:** The relay selected in this example is a 4PDT .150-grid relay, voltage calibrated, end bracket mounting, 0.13 inch solder hook header, 720 ohms coil resistance, and 210 mW sensitivity. By choosing the proper code for each of these relay characteristics, the catalog number is identified as 3SDH5131K1. The letter R following sensitivity code indicates relay received 5000 operation miss-test. Ex. 3SDH5131K1R.

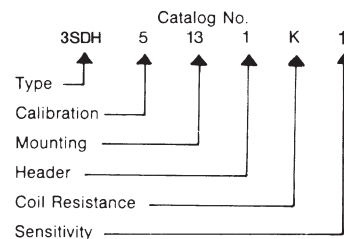

## Four Pole, Magnetic Latching, 2 Amps and Less

### .150 Grid-space Magnetic Latching Relays Type 3SBM (4PDT)

#### Product Facts

- Low profile... only 0.32 inches high
- Internal diode for coil transient suppression available
- Qualified to MIL-R-39016/31
- Suitable for low pulse operation — 2 ms at rated voltage

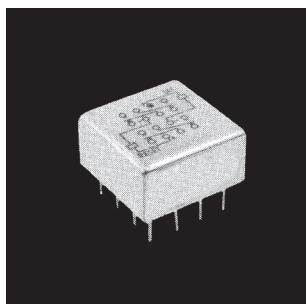

The Type 3SBM relay adds magnetic latching capability to the popular and growing family of .150-grid relays. This relay has memory in that the contact positions do not change when coil power is removed. Switching is accomplished by applying power to the applicable coil (dual coil) or with the applicable polarity (single coil). The low switching power requirements are further enhanced by its ability to operate from capacitor discharge or other pulses or through its own contacts from batteries or similarly limited supplies.

#### Electrical Characteristics

**Operate Sensitivity**—  
Single-coil form, 100 mW,  
Dual-coil form, 180 mW

**Contact Arrangement**—  
4-pole double-throw (4C)

**Contact Ratings** —  
DC resistive — 2 amps at 28 volts  
DC inductive — 0.5 amp at 28 volts,  
200 mH  
AC resistive — 0.5 amp at 115 volts  
(enclosure isolated from ground, or  
enclosure and movable contact at same  
potential)  
AC — 0.125 amp at 115 volts  
(enclosure at line potential with respect  
to movable contact)  
Low-level — 50  $\mu$ A at 50 mV  
Peak AC or DC

**Contact Resistance** —  
0.050 ohms max.;  
0.150 ohms after life tests

**Life** —  
100,000 operations at rated loads listed;  
1,000,000 operations at low-level loads

#### Operating Characteristics

**Operate Time** — 4 ms max.  
**Release Time** — 4 ms max.  
**Contact Bounce** — 1.5 ms  
**Dielectric Strength** —  
500 volts rms at sea level;  
350 volts rms at 70,000 feet and above  
**Insulation Resistance** —  
1,000 megohms min. over temperature  
range

**Environmental Characteristics**  
**Vibration** — 30 G, 55 to 3,000 Hz  
**Shock** — 150 G at 11 ms  
**Temperature** — -65°C to +125°C

See page 1-62 for Mounting Forms,  
Terminals and Circuit Diagrams.

Coil Table (All Values DC)\*

Coil Code Letter	SINGLE COIL, SENSITIVITY 1, (100 mW)			
	Coil Resistance @ 25C (Ohms) $\pm$ 10%	Maximum Set-Reset Values		Suggested Source Volts†
		Calibration Code 5 Voltage (Volts)	Calibration Code 6 Current (mA)	
N	57	2.4	42	3.6– 8.5
R	256	5.1	20	7.6–18
T	830	9.1	11	14–32
V	1700	13.0	7.7	20–46
W	3250	18.0	5.5	28–63

Coil Code Letter	DUAL COIL, SENSITIVITY CODE 2, (180 mW)			
	Coil Resistance @ 25C (Ohms) $\pm$ 10%	Maximum Set-Reset Values		Suggested Source Volts†
		Calibration Code 5 Voltage (Volts)	Calibration Code 6 Current (mA)	
H	10	1.4	135	2.0– 3.7
N	37	2.6	70	3.8– 7.2
R	145	5.2	35	7.6–14.5
T	450	9.0	20	14–25
V	975	13.5	13.5	20–35
W	2140	20.0	9.2	30–54

\*Values listed are factory test and inspection values. User should allow for meter variations.  
†Applicable over the operating temperature range in circulating air.

#### Ordering Instructions

Type 3SBM relays can be ordered by specifying the correct catalog number. This number is derived by choosing the proper CODE for each of the six relay characteristics in the order in which the codes are listed.

**Example:** The relay selected in this example is a dual coil, current calibrated, four-hole end bracket mounting, solder hook header, 37 ohms coil resistance, and 180 mW sensitivity. By choosing the proper code for each of these relay characteristics, the catalog number is identified as 3SBM6131N2. The letter R following sensitivity code indicates relay received 5000 operation miss-test. Ex. 3SBM6131N2R.

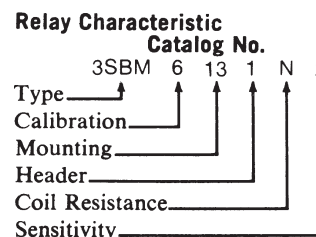

\* The part number example shown on this page is for catalog items. For a list of specific QPL part numbers, please see the index in Section 15.

**.150 Grid-space Hybrid Magnetic Latching Relays Single Diode, Dual Diode Type 3SBM (4PDT)**

**Product Facts**

- Low profile... only 0.32 inches high
- Suitable for pulse operation
- Qualified to MIL-R-39016/35
- Qualified to MIL-R-39016/36

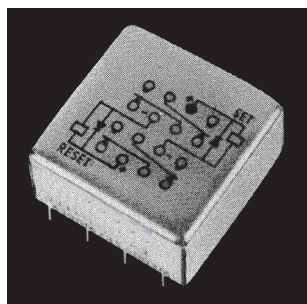

The dual coil version of the 3SBM magnetic latching relay is now available with coil transient suppression with or without blocking diodes for reverse polarity protection. This hybrid magnetic latching relay is an addition to the growing family of .150 grid relays. The diode method is employed to limit the back EMF generated when the coil circuit is opened in order to protect other circuit components such as semiconductors. The contact load

capabilities of the 3SBM as well as the memory feature of the latching function are both maintained.

**Electrical Characteristics**

**Contact Arrangement**— 4-pole double-throw (4C)

**Operate Sensitivity**— Single-coil form, 100 mW, Dual-coil form, 180 mW per coil

**Contact Ratings** — DC resistive — 2 amps at 28 volts DC inductive — 0.5 amp at 28 volts, 200 mH AC resistive — 0.5 amp at 115 volts (enclosure isolated from ground, or enclosure and movable contact at same potential) AC — 0.125 amp at 115 volts (enclosure at line potential with respect to movable contact) Low-level — 50  $\mu$ A at 50 mV Peak AC or DC

**Contact Resistance** — 0.050 ohms max.; 0.150 ohms after life test

**Life** — 100,000 operations at rated loads listed; 1,000,000 operations at low-level loads

**Operating Characteristics**

**Operate Time** — 4 ms max.

**Release Time** — 4 ms max.

**Contact Bounce** — 1.5 ms

**Dielectric Strength (Note 1)** — 500 volts rms at sea level; 350 volts rms at 70,000 feet and above

**Insulation Resistance (Note 1)** — 1,000 megohms min. over temperature range

**Environmental Characteristics**

**Vibration** — 30 G, 55 to 3,000 Hz

**Shock** — 150 G at 11 ms

**Temperature** — -65°C to +125°C

**Semiconductor Characteristics at 25°C**

**Max. Negative Transient** — 1 volt

**Breakdown Voltage** — 100 Vdc min.

**Max. Leakage Current** — 1  $\mu$ A @ 50 Vdc

**Note 1:** Tests for dielectric withstanding voltage and insulation resistance should be made with "coil terminals" shorted together to avoid unnecessary electrical stress to semiconductor elements.

See page 1-62 for Mounting Forms, Terminals and Circuit Diagrams.

**Coil Table Single Diode (All Values DC)\***

Coil Code Letter	Dual Coil, Sensitivity Code 5 (180 mW)			Suggested Source Volts†
	Coil Resistance @ 25C (ohms) $\pm$ 10%	MAX. SET—RESET VALUES		
		Calibration Code 5 Voltage (Volts)	Calibration Code 6 Current (mA)	
H	10	1.4	135	2.0- 3.7
N	37	2.6	70	3.8- 7.2
R	145	5.2	35	7.6-14.5
T	450	9.0	20	14-25
V	975	13.5	3.5	20-35
W	2140	20.0	9.2	30-54

**Coil Table Dual Diode (All Values DC)\***

Coil Code Letter	Dual Coil, Sensitivity Code 6 (180 mW)			Suggested Source Volts†
	Coil Resistance @ 25C (ohms) $\pm$ 10%**	MAX. SET—RESET VALUES		
		Calibration Code 5 Voltage (Volts)	Calibration Code 6 Current (mA)	
H	10	2.4	135	2.6- 4.1
N	37	3.6	70	3.8- 7.2
R	145	6.2	35	7.6-14.5
T	450	10.0	20	14.0-25.0
V	975	14.5	13.5	20.0-35.0
W	2140	21.0	9.2	30.0-45.0

\*Values listed are factory test and inspection values. User should allow for meter variations.

†Applicable over the operating temperature range in circulating air.

\*\*Coil resistance cannot be measured by conventional bridge.

**Note:** See page 1-60 for ordering instructions.

\* The part number example shown on this page is for catalog items. For a list of specific QPL part numbers, please see the index in Section 15.

Four Pole, Magnetic Latching, 2 Amps and Less (Continued)

Mounting Forms (3SBM)

(Vibration note with each form is acceleration from 55 to 3000 Hz)

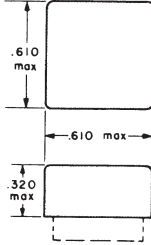

No Mount

Mounting Code	Vibration*
00	30g

\*Assumes relay held securely by potting or other means.

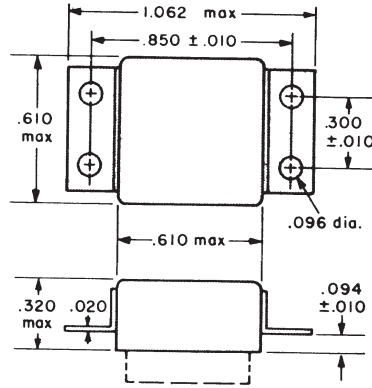

End Bracket

Mounting Code	Vibration
13	30g

ALL DIMENSIONS IN INCHES

TOLERANCES	
Unless otherwise specified:	
Hundredths	±0.020
Thousandths	±0.005

Header and Connection Diagrams

Dual Coil

When the SET coil is pulsed with plus polarity on the blue bead, the movable contacts take the position shown in the connection diagram. The contacts are transferred when the RESET coil is pulsed with plus polarity on the reset terminal. A new pulse of the SET coil with plus polarity on the blue bead will transfer the contacts back.

The contacts can also be transferred by applying a pulse of opposite polarity to the coil previously pulsed. However, this method requires slightly more power than the more normal form of operation described in the previous paragraph.

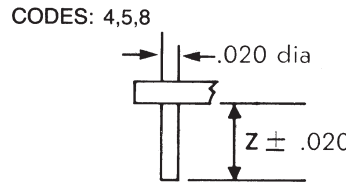
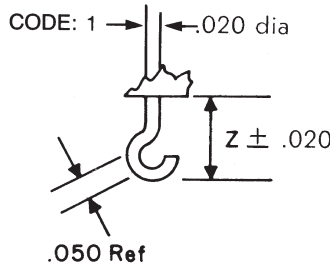

Header Types

Type	Z Dimension	Header Code
Solder Hook	0.13	1
Straight Pin	0.12	8
Straight Pin (socket or PCB type)	0.19	4
Straight Pin	0.25	5

Terminal numbers for reference only

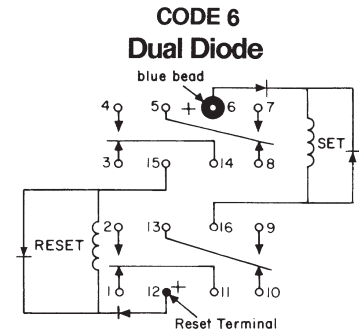
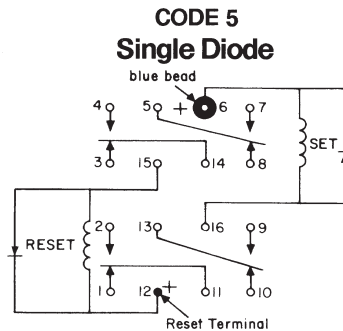
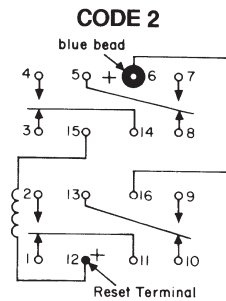
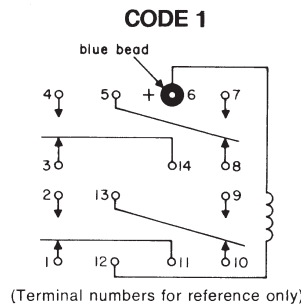
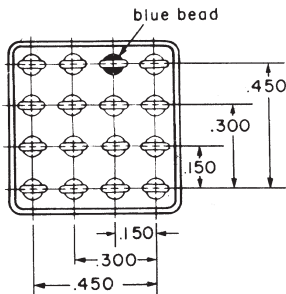

Six Pole, Electrically Held, 2 Amps and Less

SS

SS

Six Pole Half Size High Performance Relay

Designed to MIL-R-39016

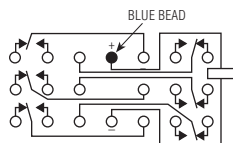

Terminal View

Product Facts

- Hermetically sealed
- Up to 2 amps switching
- High shock & vibration ratings
- Optional terminals & mounting styles
- 6 form C Hi-density design

Electrical Characteristics

Contact Arrangement —

6 Form C (6PDT)

Contact Material —

Stationary — Gold plated hardened silver alloy

Moveable — Gold plated hardened silver alloy

Gold plated hardened silver alloy

Gold plated hardened silver alloy

Contact Resistance —

Before Life — 50 milliohms max.

(measured at 10 mA @ 6 Vdc)

After Life — 100 milliohms max.

(measured @ 2 A @ 28 Vdc)

Mechanical Life Expectancy —

1 million operations min.

Coil Voltage — 5 to 26.5 Vdc

Coil Power — 2.6 watts max. @ 25°C

Duty Cycle — Continuous

Pick-up Voltage — Approximately

50% of nominal coil voltage

Pick-up Sensitivity — 475 mW

Contact Ratings

Contact Load	Type	Operations Min.
2 A @ 28 Vdc	Resistive	100,000
0.3 A @ 115 Vac, 60 Hz & 400 Hz	Resistive	100,000
0.75 A @ 28 Vdc	Inductive (200mH)	100,000
0.1 A @ 28 Vdc	Intermediate	50,000
0.2 A @ 28 Vdc	Lamp	100,000
10 µA @ 50 mV	Low Level	1,000,000

Six Pole, Electrically Held, 2 Amps and Less (Continued)

SS (Continued)

**Operating Characteristics**

**Timing** —  
 Operate Time — 5.0 ms max.  
 Release Time — 5.0 ms max.  
**Contact Bounce** — 5.0 ms max  
**Dielectric Withstanding Voltage** —  
 Between Open Contacts —  
 350 Vrms 60 Hz  
 Between Adjacent Contacts —  
 500 Vrms 60 Hz  
 Between Contacts & Coil —  
 500 Vrms 60 Hz  
**Insulation Resistance** —  
 1,000 megohms min. @ 500 Vdc

**Environmental Characteristics**

**Temperature Range** —  
 -65°C to +125°C  
**Weight** —  
 0.28 oz. (7.8 grms)  
**Vibration Resistance** —  
 15 G's, 10 to 2,000 Hz  
**Shock Resistance** —  
 100 G's, 6 ±1 ms  
**QPL Equivalent** —  
 MIL-R-39016

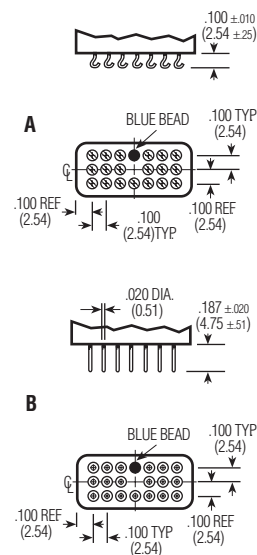

SS Terminals

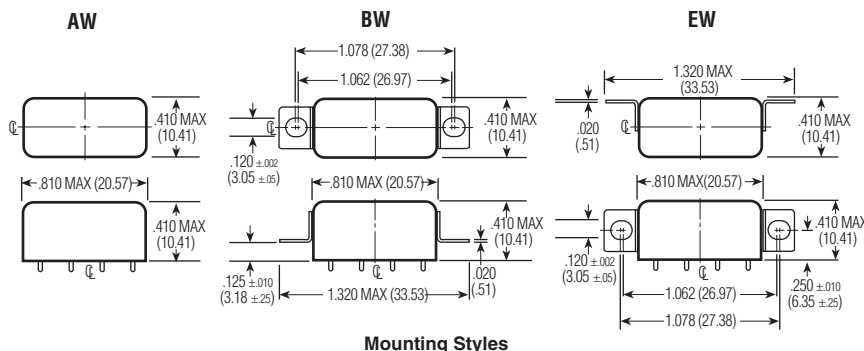

Mounting Styles

Standard Coil Data

Nom. Coil Voltage (Vdc)	Coil Resistance in Ohms ±10% @ 25°C	Pickup Voltage Vdc (Max.) @ 25°C	Pickup Voltage Vdc (Max.) @ 125°C	Drop-out Voltage Vdc (Min.) @ 25°C	Drop-out Voltage Vdc (Min.) @ -65°C	Nom. Coil Power (W) @ 25°C	Max. Coil Voltage	Coil Desig.
5.0	20	2.75	3.8	0.35	0.23	1.25	6.0	5
6.0	25	3.5	4.5	0.45	0.3	1.44	8.0	6
12.0	100	6.5	9.0	0.9	0.6	1.44	15.0	12
26.5	390	14.0	18.0	1.8	1.2	1.8	32.0	24

Specifying a Part Number Example:

**Type** SS      **Mountings** BW-      **Contacts** 6C-      **Coils** 24      **Terminals** B

**Double Pole, Electrically Held, 5 Amps and Less**

**HFW4A, HFW5A**

**HFW4A, HFW5A**  
**Standard Half Size**  
**High Performance Relay**  
**Designed to**  
**MIL-R-39016/6**

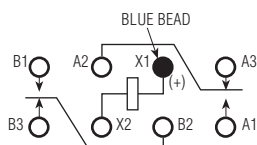
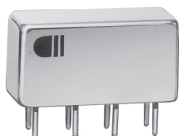

Terminal View

**Product Facts**

- Hermetically sealed
- Up to 5 amps switching
- High shock & vibration ratings
- Optional terminals & mounting styles
- Excellent RF switching

**Electrical Characteristics**

**Contact Arrangement** — 2 Form C (DPDT)

**Contact Material** — Stationary —

Hardened silver alloy

Moveable —

Gold plated hardened silver alloy

**Contact Resistance** —

Before Life — 50 milliohms max.

(measured at 10 mA @ 6 Vdc)

After Life — 100 milliohms max.

(measured @ 2 A @ 28 Vdc)

**Mechanical Life Expectancy** —

50 million operations

**Coil Voltage** —

5 to 48 Vdc (HFW4A)

5 to 26.5 Vdc (HFW5A)

**Coil Power** — 1.4 watts max. @ 25°C

**Duty Cycle** — Continuous

**Pick-up Voltage** — Approximately

50% of nominal coil voltage

**Pick-up Sensitivity @ 25°C** —

145 to 260 mW

**Contact Ratings**

Contact Load	Type	Operations Min.
4 A @ 28 Vdc (HFW4A)	Resistive	100,000
5 A @ 28 Vdc (HFW5A)	Resistive	100,000
0.75 A @ 28 Vdc	Inductive (200mH)	100,000
0.1 A @ 115 Vac, 60 Hz & 400 Hz	Resistive	100,000
0.3 A @ 115 Vac, 60 Hz & 400 Hz	Resistive	100,000
0.1 A @ 28 Vdc	Intermediate	50,000
0.160 A @ 28 Vdc	Lamp	100,000
30 µA @ 50 mVdc	Low Level	1,000,000

**RF Performance**

Frequency (MHz)	RF Losses (dB)	VSWR	Isolation (dB)
100	0.1	1.17:1	40
500	0.3	1.19:1	28
1000	0.4	1.19:1	23

Double Pole, Electrically Held, 5 Amps and Less (Continued)

HFW4A, HFW5A (Continued)

Operating Characteristics

- Timing** —  
Operate Time — 4.0 ms max.  
Release Time — 4.0 ms max.
- Contact Bounce** — 2.0 ms max.
- Dielectric Withstanding Voltage**  
— Between Open Contacts —  
500 Vrms 60 Hz  
Between Adjacent Contacts —  
1000 Vrms 60 Hz  
Between Contacts & Coil —  
1000 Vrms 60 Hz
- Insulation Resistance** —  
10,000 megohms min. @ 500 Vdc

Environmental Characteristics

- Temperature Range** —  
-65°C to +125°C
- Weight** — 0.46 oz. (13 gms max.)
- Vibration Resistance** —  
20 G's, 10 to 2,000 Hz
- Shock Resistance** —  
100 G's, 6 ±1 ms

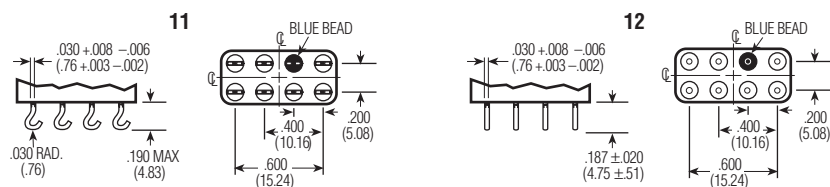

Terminals

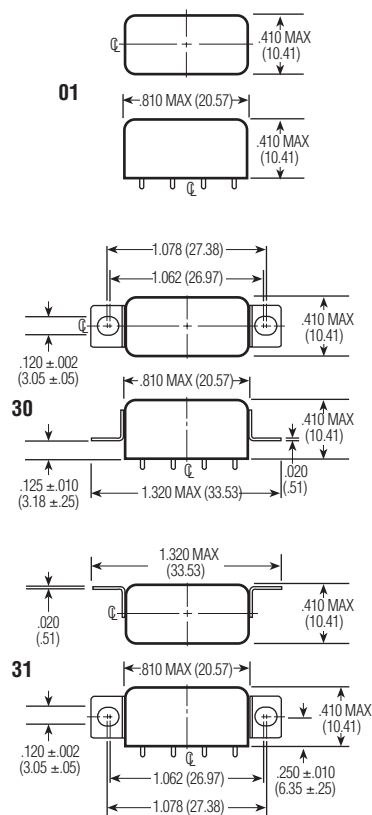

Mounting Styles

Standard Coil Data

	Nom. Coil Voltage (Vdc)	Coil Resistance in Ohms ±10% @ 25°C	Pickup Voltage Vdc (Max.) @ 25°C	Pickup Voltage Vdc (Min.) @ 125°C	Drop-out Voltage Vdc (Min.) @ 25°C	Drop-out Voltage Vdc (Min.) @ -65°C	Nom. Coil Power (mW) @ 25°C	Max. Coil Voltage	Coil Desig.
HFW4A/HFW5A	5.0	27	2.7	3.8	0.29	0.21	926	6.0	L
	6.0	40	3.2	4.5	0.35	0.25	900	7.5	F
	12.0	160	6.4	9.0	0.7	0.5	900	15.0	G
	26.5	700	13.5	18.0	1.5	1.0	1003	32.0	K
Other	6-8	60	3.5	4.85	0.35	0.22	817	9.0	A
	12-15	320	6.8	9.42	0.68	0.44	570	21.0	B
HFW4A relays only)	18.0	520	9.5	13.16	0.95	0.62	623	27.0	J
	26.5-32	1,250	14.0	19.4	1.5	0.98	684	42.0	D
	40.0	2,700	21.3	29.5	2.1	1.37	593	61.0	H
	48.0	3,500	25.5	35.3	2.5	1.63	658	70.0	E

Specifying a Part Number Example:

<b>Type</b>	<b>Terminals</b>	<b>Mountings</b>	<b>Coils</b>	<b>Features</b>
HFW5A	12	30	K	00

**HFC4A, HFC5A**  
Commercial/Industrial  
Half Size Relay

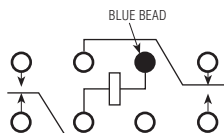
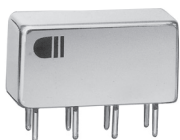

Terminal View

**Product Facts**

- Hermetically sealed
- Up to 5 amps switching
- Economical configuration
- Optional terminals & mounting styles

**Double Pole, Electrically Held, 5 Amps and Less (Continued)**

**Electrical Characteristics**

**Contact Arrangement** — 2 Form C (DPDT)  
**Contact Material** — Stationary — Bifurcated hardened silver alloy  
 Moveable — Gold plated hardened alloy  
**Contact Resistance** — Before Life — 50 milliohms max. (measured at 10 mA @ 6 Vdc)  
 After Life — 100 milliohms max. (measured @ 2 A @ 28 Vdc)  
**Mechanical Life Expectancy** — 10 million operations  
**Coil Voltage** — 5 to 26.5 Vdc  
**Coil Power** — 1.4 watts max. @ 25°C

**Duty Cycle** — Continuous  
**Pick-up Voltage** — Approximately 60% of nominal coil voltage  
**Pick-up Sensitivity** — 360 mW

**Operating Characteristics**  
**Timing** — Operate Time — 6.0 ms max.  
 Release Time — 6.0 ms max.

**Dielectric Withstanding Voltage**  
 — Between Open Contacts — 350 Vrms 60 Hz  
 Between Adjacent Contacts — 500 Vrms 60 Hz  
 Between Contacts and Coil — 500 Vrms 60 Hz  
**Insulation Resistance** — 1,000 megohms min @ 500 Vdc

**Environmental Characteristics**

**Temperature Range** — -55°C to +85°C  
**Weight** — 0.46 oz. (13 gms) max.  
**Vibration Resistance** — 10 G's, 10 to 500 Hz  
**Shock Resistance** — 30 G's, 6 ±1 ms

**Contact Ratings**

	Contact Load	Type	Operations Min.
HFC4A	4 A @ 28 Vdc	Resistive	100,000
HFC5A	5 A @ 28 Vdc	Resistive	100,000
	0.75 A @ 28 Vdc	Inductive (200 mH)	100,000
	0.3 A @ 115 Vac, 60 Hz & 400 Hz	Resistive	100,000

**Standard Coil Data**

Nom. Coil Voltage (Vdc)	Coil Resistance in Ohms ± 20% @ 25°C	Pickup Voltage Vdc (Max.) @ 25°C	Pickup Voltage Vdc (Max.) @ 85°C	Nom. Coil Power (W) @ 25°C	Max. Coil Voltage	Coil Desig.
5.0	27	3.0	3.7	.92	6.0	L
6.0	40	3.6	4.5	.90	7.5	F
12.0	160	7.2	8.9	.90	15.0	G
26.5	700	16.0	19.7	1.00	32.0	K

01

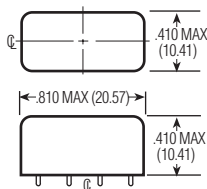

30

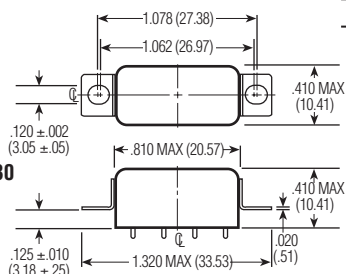

31

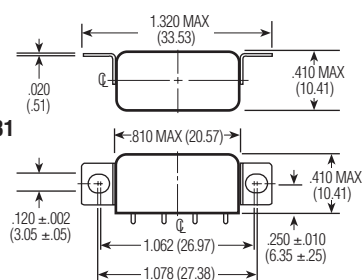

Mounting Styles

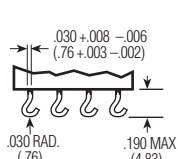

11

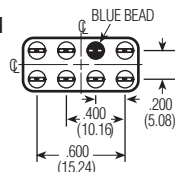

Terminals

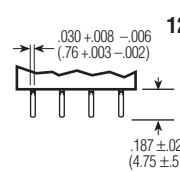

12

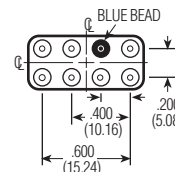

**Specifying a Part Number Example:**

**Type** HFC5A    **Terminals** 12    **Mountings** 30    **Coils** K    **Features** 00

Double Pole, Electrically Held, 5 Amps and Less (Continued)

**FW, FW5A, SF, SF5A**  
**Two Pole Full Size**  
**Crystal-Can Relay**  
**FW Qualified to**  
**MIL-R-5757/10**

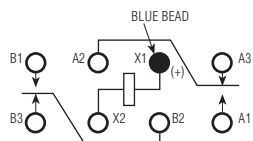
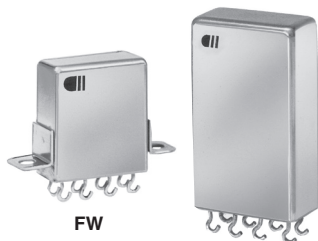

Terminal View

**Product Facts**

- Hermetically sealed
- Up to 5 amps switching
- High shock & vibration ratings
- Optional terminals & mounting options
- Excellent RF switching

**Electrical Characteristics**

**Contact Arrangement** — 2 Form C  
**Contact Material** — Stationary — Bifurcated hardened silver alloy  
 Moveable — Gold plated hardened alloy  
**Contact Resistance** — Before Life — 50 milliohms max. (measured at 10 mA @ 6 Vdc)  
 After Life — 100 milliohms max. (measured @ 2 mA @ 28 Vdc)  
**Mechanical Life Expectancy** — 50 million operations  
**Coil Voltage** — 6.3 to 110 Vdc (FW, FW5A)  
 1.8 to 40 Vdc (SF)  
 2.8 to 40 Vdc (SF5A)  
**Coil Power** — 1.5 watts max. @ 25°C  
**Duty Cycle** — Continuous  
**Pick-up Voltage** — Approximately 50% of nominal coil voltage  
**Pick-up Sensitivity** — 250 mW (FW, FW5A)  
 40 mW (SF)  
 80 mW (SF5A)

**Operating Characteristics**

**Operate Time** — 15 ms max. (SF)  
 5 ms (FW, FW5A)  
 6 ms max. (MIL-R-5757/10)  
**Release Time** — 10 ms max. (SF)  
 5 ms max. (FW, FW5A)  
 6 ms max. (MIL-R-5757/10)  
**Contact Bounce** — 2 ms max.  
**Dielectric Withstanding Voltage** — Between Open Contacts — 500 Vrms 60 Hz  
 Between Adjacent Contacts — 1,000 Vrms 60 Hz  
 Between Contacts and Coil — 1,000 Vrms 60 Hz  
**Insulation Resistance** — 10,000 megohms min @ 500 Vdc

**Environmental Characteristics**

**Temperature Range** — -65°C to +125°C  
**Weight** — 0.6 oz. max. (FW, FW5A)  
 0.7 oz. max. (SF 6)  
 1.1 oz. max. (SF/SF 5A)  
**Vibration Resistance** — Standard — 20 G's, 10 to 2000 Hz (FW, FW5A)  
 15 G's, 10 to 2000 Hz (SF)  
 QPL — 20 G's, 10 to 2000 Hz  
**Shock Resistance** — 100 G's, 6 ±1 ms  
**QPL Approval** — MIL-R-5757/10 (FW only)  
**QPL Equivalent** — MIL-R-5757/13 (SF only)

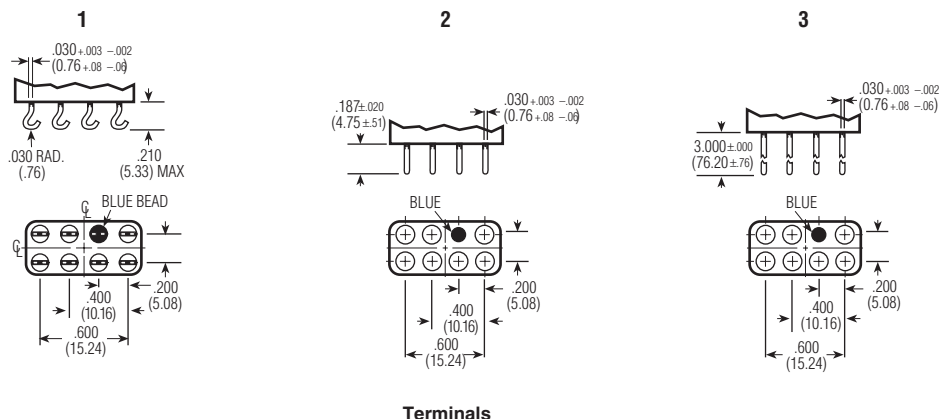

Terminals

**RF Performance**

Frequency (MHz)	RF Losses (dB)	VSWR	Isolation (dB)
100	0.1	1.17:1	40
250	0.2	1.18:1	33
500	0.3	1.19:1	28
750	0.4	1.19:1	25
1,000	0.4	1.19:1	23

**Contact Ratings**

Contact Load	Type	Operations Min.
5 A @ 28 Vdc (FW5A/SF5A)	Resistive	100,000
3 A @ 28 Vdc (FW)	Resistive	100,000
2 A @ 28 Vdc (SF)	Resistive	100,000
1 A @ 115 Vac, 60 Hz & 400 Hz (FW)	Resistive	100,000
0.3 A @ 115 Vac, 60 Hz & 400 Hz (SF)	Resistive	100,000
1 A @ 28 Vdc	Inductive (200 mH)	100,000
0.1 A @ 28 Vdc	Lamp	100,000
10 µA @ 50 mVdc	Low Level	1,000,000
75 WATTS @ 50 MHz (FW)	RF	10,000,000

Double Pole, Electrically Held, 5 Amps and Less (Continued)

FW, FWSA Coil Data

Nom. Coil Voltage (Vdc)	Coil Resistance in Ohms ±10% @ 25°C	Pickup Voltage Vdc (Max.) @ 25°C	Pickup Voltage Vdc (Max.) @ 125°C	Drop-out Voltage Vdc (Min.) @ 25°C	Drop-out Voltage Vdc (Min.) @ -65°C	Nom. Coil Power (W) @ 25°C	Max. Coil Voltage	Coil Desig.
6.3	35	3.2	4.4	0.35	0.23	1.13	7.9	A
12.6	200	6.8	9.4	0.74	0.49	.79	15.8	D
17.6	340	8.9	12.3	0.97	0.64	.91	22.0	E
26.5	675	13.5	18.7	1.47	0.96	1.04	33.1	G
32.0	975	15.5	21.5	1.69	1.1	1.05	40.0	H
48.0	2,450	25.0	34.7	2.73	1.8	.94	60.0	L
56.0	3,150	30.0	41.6	3.27	2.1	1.90	70.0	M
75.0	5,000	38.0	52.7	4.14	2.7	1.13	93.8	N
110.0	9,100	51.0	70.7	5.56	3.6	1.33	137.5	R

SF5/SF6 Coil Data

Nom. Coil Voltage (Vdc)	Nom. Current (mA)	Coil Resistance in Ohms ± 10% @ 25°C	Pickup Current (mA) @ 25°C	Nom. Coil Power (mW) @ 25°C	Coil Desig.
1.8	90.0	20	45.0	162	A
9.0	18.0	500	9.0	162	E
12.6	12.6	1,000	6.5	159	F
16.5	11.0	1,500	5.2	182	G
18.0	9.0	2,000	4.5	162	H
20.0	8.0	2,500	4.0	160	J
26.5	5.3	5,000	2.8	140	W
36.0	4.5	8,000	2.3	162	L
40.0	4.0	10,000	2.0	160	Y

SF5A Coil Data

Nom. Coil Voltage (Vdc)	Nom. Current (mA)	Coil Resistance in Ohms ± 10% @ 25°C	Pickup Current (mA) @ 25°C	Nom. Coil Power (mW) @ 25°C	Coil Desig.
2.8	140.0	20	65.0	392	A
4.0	80.0	50	41.6	320	B
12.0	24.0	500	12.5	288	E
18.0	18.0	1,000	9.3	324	F
26.5	10.6	2,500	5.6	281	J
40.0	8.0	5,000	4.0	320	W

NOTE:  
FW/FW5A = .875 (22.23) Max.  
SF6 = .900 (22.86) Max.  
SF5/SF5A5 = 1.281 (32.54) Max.

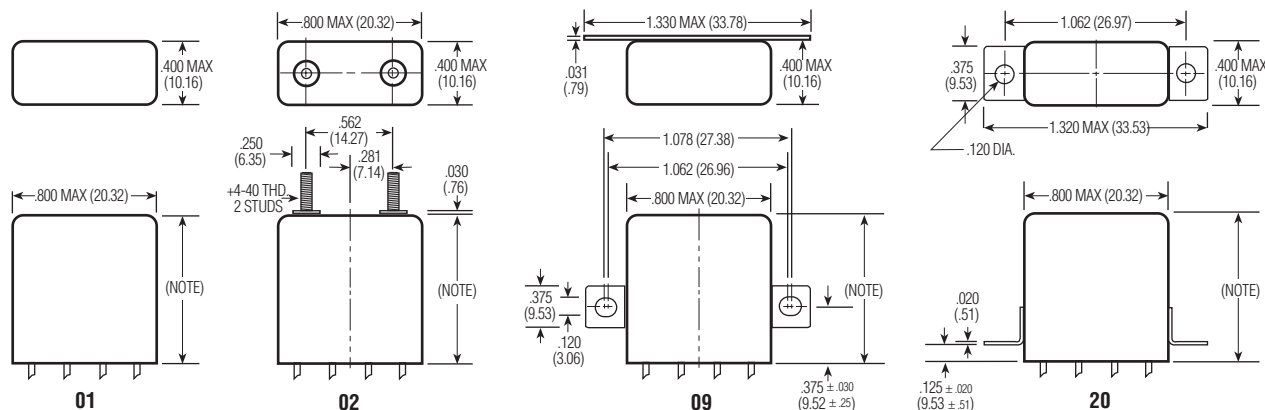

Mounting Styles

Specifying a Part Number Example:

Type	Series	Terminals	Mountings	Coils	Features
FW	1	1	20	G	00
SF	5	1	20	W	00
SF5A	5	1	20	W	00
SF	6	1	20	W	00

## Single Pole, Electrically Held, 10 Amps and Less

**C**  
Single Pole, Half Size  
High Performance Relay

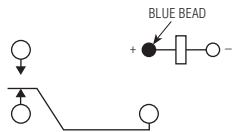

Terminal View

**Product Facts**

- Hermetically sealed
- Up to 10 amps switching
- High shock & vibration ratings
- Optional terminals & mounting styles

**Electrical Characteristics**

**Contact Arrangement** — 1 Form C (SPDT)  
**Contact Material** — Stationary — Hardened silver alloy  
 Moveable — Hardened silver alloy  
**Contact Resistance** — Before Life — 50 Milliohms max. (measured at 10 mA @ 6 Vdc)  
 After Life — 100 Milliohms max. (measured @ 1 A @28 Vdc)  
**Contact Rating** — Contact Load — 10 A 28 Vdc  
 Type — Resistive  
 Operations min. 50,000  
**Mechanical Life Expectancy** — 1 million operations min.  
**Coil Voltage** — 6 to 26.5 Vdc  
**Coil Power** — 1.4 watts max. @ 25°C  
**Duty Cycle** — Continuous

**Pick-up Voltage** — Approximately 50% of nominal coil voltage  
**Pick-up Sensitivity** — 260 mW  
**Operational Characteristics**  
**Operate Time** — 5.0 ms max.  
**Release Time** — 5.0 ms max.  
**Contact Bounce** — 5.0 ms max.  
**Dielectric Withstanding Voltage** — Between Open Contacts — 500 Vrms 60 Hz  
 Between Adjacent Contacts — 1000 Vrms 60 Hz  
 Between Contacts and Coils — 1000 Vrms 60 Hz  
**Insulation Resistance** — 1,000 megohms min. @ 500 Vdc

**Environmental Characteristics**  
**Temperature Range** — -65°C to +125°C  
**Weight** — 0.28 oz. (8 grams) max.  
**Vibration Resistance** — 20 G's, 10 to 2,000 Hz  
**Shock Resistance** — 100 G's, 6 ±1 ms  
**Designed To** — MIL-R-39016

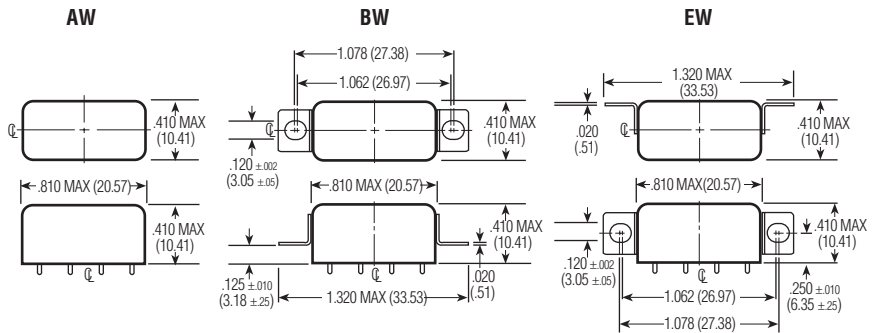

Mounting Styles

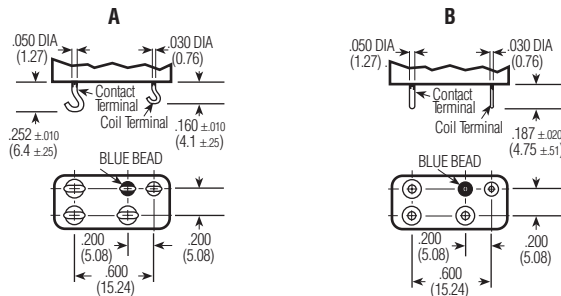

Terminals

**Standard Coil Data**

Nom. Coil Voltage (Vdc)	Coil Resistance in Ohms ±10% @ 25°C	Pickup Voltage Vdc (Max.) @ 25°C	Pickup Voltage Vdc (Max.) @ 125°C	Drop-out Voltage Vdc (Min.) @ 25°C	Drop-out Voltage Vdc (Min.) @ -65°C	Nom. Coil Power (W) @ 25°C	Max. Coil Voltage	Coil Desig.
6.0	40	3.5	4.5	0.45	0.3	.9	8.0	6
12.0	160	6.5	9.0	0.9	0.6	.9	15.0	12
26.5	700	14.0	18.0	1.8	1.2	1.0	32.0	24

**Specifying a Part Number Example:**

**Type** C      **Mountings** BW-      **Contacts** 1C-      **Coils** 24      **Terminals** B

**07**  
**Two Pole 10 Amp**  
**High Performance Relay**  
**Qualified to**  
**MIL-R-5757/23**  
**MS 27245 & MS 27247**

**Product Facts**

- Hermetically sealed
- Up to 10 amps switching
- High shock & vibration ratings
- Optional terminals & mounting styles
- DC, AC & diode-suppressed coils

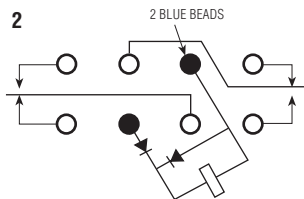

Terminal View

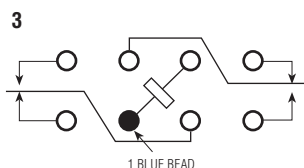

Terminal View

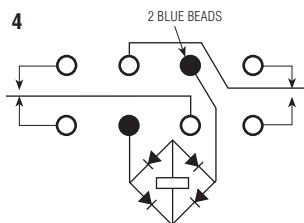

Terminal View

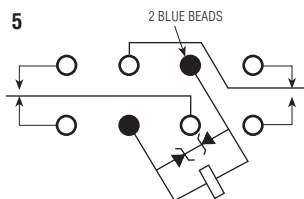

Terminal View

**Double Pole, Electrically Held, 10 Amps and Less**

**Electrical Characteristics**

**Contact Arrangement** — 2 Form C (DPDT)  
**Contact Material** — Stationary — Silver cadmium oxide  
 Moveable — Silver cadmium oxide  
**Contact Resistance** — Before Life — 10 milliohms max.  
 After life — 20 milliohms max.  
 (Measured at 10 A @ 28 Vdc)  
**Mechanical Life Expectancy** — 1 million operations  
**Coil Voltage** — 6 to 120 Vdc, 115 Vac  
**Coil Power** — 4.3 watts max. @ 25°C  
**Duty Cycle** — Continuous  
**Pick-up Voltage** — Approximately 50% of nominal coil voltage  
**Pick-up Sensitivity** — 565 mW

**Operating Characteristics**

**Operate Time** — Std — 10 ms max.  
 QPL — 15 ms max.  
 AC Coil — 15 ms max.  
**Release Time** — Std — 10 ms max.  
 QPL — 15 ms max.  
 AC Coil — 20 ms max.  
**Contact Bounce** — Std — 5 ms max. (N.O. and N.C.)  
 QPL — 2 ms max. (N.O.)  
 QPL — 5 ms max. (N.C.)  
**Dielectric Withstanding Voltage**  
 — Between Open Contacts — 500 Vrms 60 Hz  
 Between Adjacent Contacts — 1000 Vrms 60 Hz  
 Between Contacts and Coil — 1000 Vrms 60 Hz  
**Insulation Resistance** — 1,000 megohms min. @ 500 Vdc

**Environmental Characteristics**

**Temperature Range** — -65°C TO +125°C  
**Weight** — 1.3 oz (37 gms) max.  
**Vibration Resistance** — Standard — 30 G's, 10 to 2,000 Hz  
 QPL — 20 G's, 10 to 2,000 Hz  
**Shock Resistance** — 100 G's, 6 ±1 ms  
**QPL Approval** — MIL-R-5757/23  
 MS 27245  
 MS 27247

**Contact Ratings**

Contact Load	Type	Operations Min.
10 A @ 28 Vdc	Resistive	100,000
3 A @ 115 V, 60 Hz	Resistive	50,000
5 A @ 115 V, 400 Hz	Resistive	50,000
6 A @ 28 Vdc	Inductive	50,000
2 A @ 115 V, 60 Hz	Inductive	50,000
2.5 A @ 115 V, 400 Hz	Inductive	50,000
1 A @ 28 Vdc	Lamp	50,000
0.5 A @ 115 V, 60 Hz	Lamp	50,000
0.8 A @ 115 V, 400 Hz	Lamp	50,000
3 A @ 28 Vdc	Motor	50,000
1.5 A @ 115 V, 60 Hz	Motor	50,000
3 A @ 115 V, 400 Hz	Motor	50,000

\*All ratings grounded case

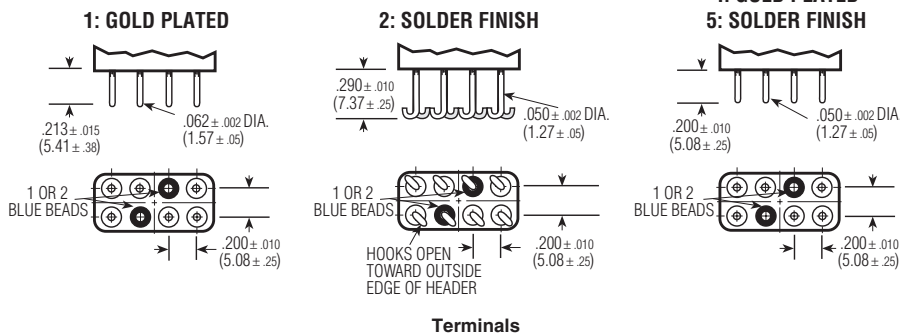

Double Pole, Electrically Held, 10 Amps and Less (Continued)

Coil Data

	Nom. Coil Voltage (Vdc)	Coil Resistance in Ohms ±10% @ 25°C	Pickup Voltage Vdc (Max.) @ 25°C	Pickup Voltage Vdc (Max.) @ 125°C	Drop-out Voltage Vdc (Min.) @ 25°C	Drop-out Voltage Vdc (Min.) @ -65°C	Nom. Coil Power (mW) @ 25°C	Max. Coil Voltage	Coil Desig.	Environmental
	6.0	19	3.6	4.5	0.4	0.25	1.89	9.0	AA	<b>Temperature</b> -55°C to +85°C
	12.0	75	7.2	9.0	0.9	0.5	1.92	16.0	AB	
	26.5	300	14.4	18.0	1.8	1.0	2.34	32.0	AC	
	48.0	1,200	29.0	36.0	3.6	2.0	1.92	52.0	AD	
	120.0	7,600	72.0	90.0	9.0	5.0	1.89	122.0	AE	
	115 Vac 400 Hz	1,200	72.0	90.0	10.0	5.0	n/a	n/a	AR	<b>Vibration</b> 20G's, 10 to 2,000Hz
	115 Vac 60-400 Hz	7,600	72.0	90.0	10.0	5.0	n/a	n/a	AS	
	6.0	19	3.3	4.5	0.4	0.25	1.89	9.0	BA	
	12.0	75	6.5	9.0	0.9	0.5	1.92	16.0	BB	
	26.5	300	13.0	18.0	1.8	1.0	2.34	32.0	BC	
	48.0	1,200	26.0	36.0	3.6	2.0	1.92	52.0	BD	<b>Vibration</b> 20G's, 10 to 2,000Hz
	120.0	7,600	66.0	90.0	9.0	5.0	1.89	122.0	BE	
	115 Vac 400 Hz	1,200	75.0	90.0	10.0	5.0	n/a	n/a	BR	
	115 Vac 60-400 Hz	7,600	75.0	90.0	10.0	5.0	n/a	n/a	BS	
	6.0	19	3.7	5.0	0.4	0.25	1.89	9.0	CA	
	12.0	75	7.4	10.0	0.9	0.5	1.92	16.0	CB	<b>Temperature</b> -65°C to +125°C
	26.5	300	14.7	20.0	1.8	1.0	2.34	32.0	CC	
	48.0	1,200	29.4	40.0	3.6	2.0	1.92	52.0	CD	
	120.0	7,600	74.0	100.0	9.0	5.0	1.89	122.0	CE	
	115 Vac 400 Hz	1,200	80.0	100.0	10.0	5.0	n/a	n/a	CR	
	115 Vac 60-400 Hz	7,600	80.0	100.0	10.0	5.0	n/a	n/a	CS	<b>Vibration</b> 30G's, 10 to 2,000Hz
	6.0	19	3.7	5.0	0.4	0.25	1.89	9.0	CA	
	12.0	75	7.4	10.0	0.9	0.5	1.92	16.0	CB	
	26.5	300	14.7	20.0	1.8	1.0	2.34	32.0	CC	
	48.0	1,200	29.4	40.0	3.6	2.0	1.92	52.0	CD	
	120.0	7,600	74.0	100.0	9.0	5.0	1.89	122.0	CE	<b>Shock</b> 50G's, 11ms
	115 Vac 400 Hz	1,200	80.0	100.0	10.0	5.0	n/a	n/a	CR	
	115 Vac 60-400 Hz	7,600	80.0	100.0	10.0	5.0	n/a	n/a	CS	

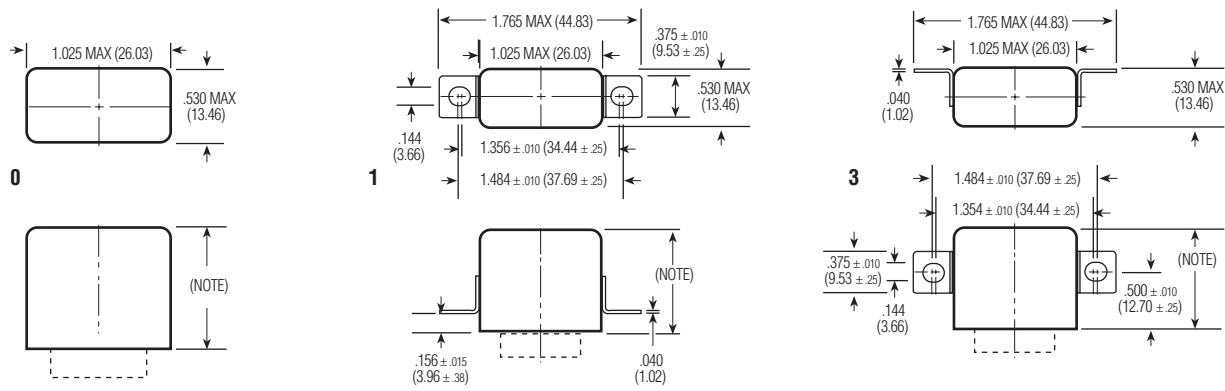

**Note:**  
 A07 = .895 max (22.73), Schematic 3 only  
 B07 = 1.010 max (25.66), Schematic 3 only  
 B07 = 1.234 max (31.35), Schematics 2, 4 & 5 only

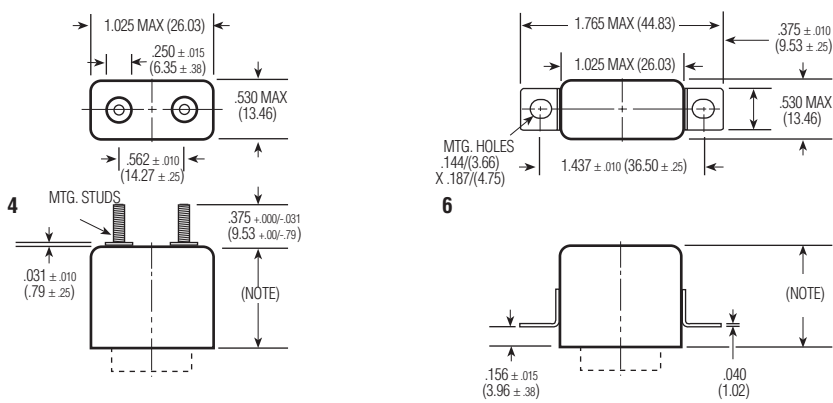

07 Mounting Styles

Specifying a Part Number Example:

Type	Rated	Mountings	Schematic	Terminals	Coil	Testing
B07	B	3	3	2	BC	1

\* The part number example shown on this page is for catalog items. For a list of specific QPL part numbers, please see the index in Section 15.

