

REVISIONS					
P	LTR	DESCRIPTION	DATE	DWN	APVD
A		REVISED PER E.O. P20503	5/27/10	AM	RDR
B		REVISED PER E.O. P20543	7/14/10	AM	RDR
C		REVISED PER PCN E-18-018867	12/4/18	AJ	DM
CI		REVISED PER PCN E-19-007592	01/09/20	CO	IG

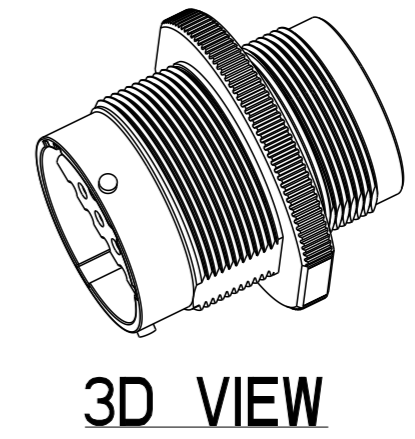
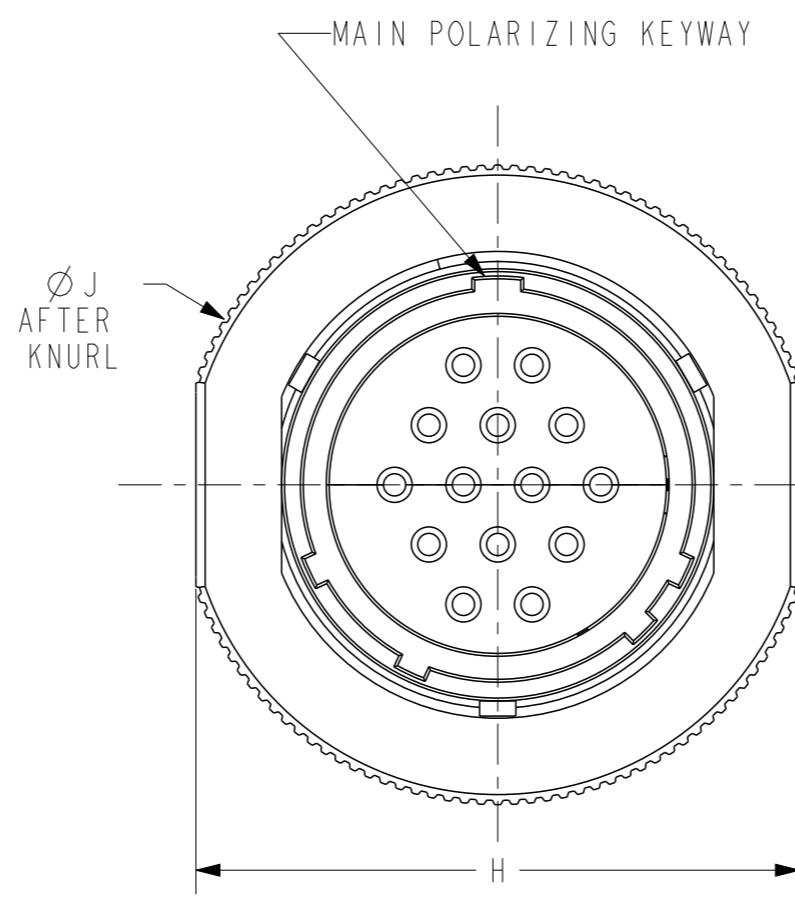
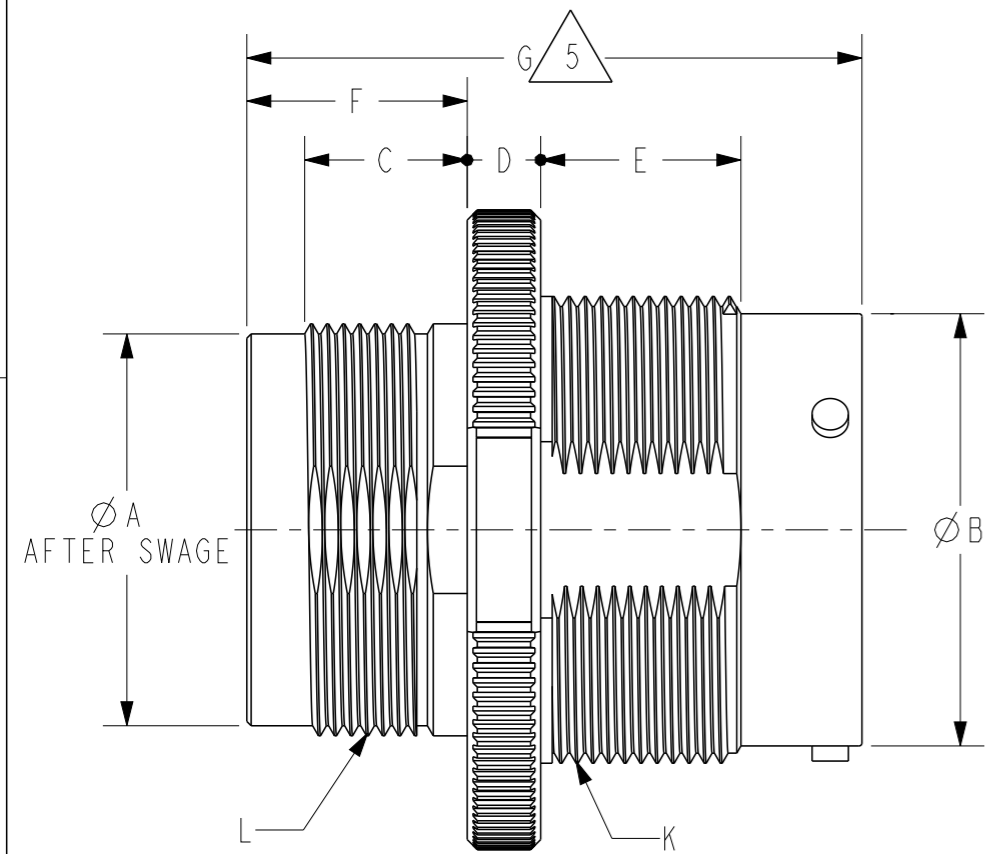

PART NUMBER	SIZE	Ø A [mm]	Ø B REF [mm]	C [mm]	D [mm]	E [mm]	F [mm]	G REF [mm]	H [mm]	Ø J [mm]	K THREAD	L THREAD
3TXXXX-24-XXP/S	24	Ø 1.368 [34.75]	Ø 1.500 [38.10]	.565 [14.35]	.255 [6.48]	.695 [17.65]	.765 [19.43]	2.248 [57.10]	2.095 [53.21]	2.220 [56.39]	1.625-18UNEF-2A MODIFIED	1.4375-18UNEF-2A MODIFIED
3TXXXX-32-XXP/S	32	Ø 1.925 [48.90]	Ø 2.110 [53.59]	.520 [13.21]	.300 [7.62]	.695 [17.65]	.720 [18.29]	2.348 [59.64]	2.925 [74.30]	3.200 [81.28]	2.250-16UN-2A	2.000-18UNS-2A MODIFIED

7. SEE SHEET 2 FOR CONTINUED NOTES.

6. PART NUMBER INFO:
 XXXX = CATERPILLAR PART NO.
 24/32 = RECEPTACLE SHELL SIZE
 XX = ARRANGEMENT NO.

5. TOTAL DIMENSION WITH WIRE SEAL.

4. FOR CONTACTS AND WIRES PERFORMANCE AND APPLICATION CHARACTERISTICS SEE CUSTOMER DRAWING 4025-001-0000.

3. FOR ARRANGEMENT OF CONTACT LOCATION SEE CUSTOMER DRAWING 4025-006-0000.

2. RECEPTACLE IS SUPPLIED WITH DUST CAP PN 6VI830 (SIZE 24), AND 6VI827 (SIZE 32) (NOT SHOWN).

1. CONSULT THE FACTORY FOR ELECTRICAL AND MATERIAL SPECIFICATIONS.

NOTES:

TE INTERNAL PN	DEUTSCH PN	REV	ARRANGEMENT	CONTACT SIZE	QTY	CONTACT TYPE
3T0204-24-20S	3T0204-24-20S	J	24-20	16	20	SOC
3T3043-32-25S	3T3043-32-25S	J	32-25	4 8 12 16	2 3 4 16	SOC
3T3410-32-37S	3T3410-32-37S	J	32-37	16	37	SOC

CONTACT SIZE	MIN. INSUL O.D.	MAX. INSUL O.D.	WIRE RANGE [mm ²] REF ONLY
4	.280 [7.11]	.420 [10.67]	4 AWG [21.0]
8	.190 [4.83]	.240 [6.10]	8-10 AWG [8.0-5.0]
12	.134 [3.40]	.170 [4.32]	10-14 AWG [5.0-2.0]
16	.100 [2.54]	.134 [3.40]	14-20 AWG [2.0-0.5]

THIS DRAWING IS A CONTROLLED DOCUMENT.		DWN A. MALAGON 12/23/09														
DIMENSIONS: in [mm]		CHK R. MILLIGAN 7/14/10														
TOLERANCES UNLESS OTHERWISE SPECIFIED:		APVD S. BEARD 7/14/10	NAME RECEPTACLE CONNECTOR SHELL SIZE 24 & 32 C.E. SERIES													
<table border="0"> <tr> <td>0 PLC</td><td>±</td></tr> <tr> <td>1 PLC</td><td>±</td></tr> <tr> <td>2 PLC</td><td>±</td></tr> <tr> <td>3 PLC</td><td>±.025 [0.64]</td></tr> <tr> <td>4 PLC</td><td>±</td></tr> <tr> <td>ANGLES</td><td>±</td></tr> </table>		0 PLC	±	1 PLC	±	2 PLC	±	3 PLC	±.025 [0.64]	4 PLC	±	ANGLES	±	PRODUCT SPEC -	SIZE A3	
0 PLC	±															
1 PLC	±															
2 PLC	±															
3 PLC	±.025 [0.64]															
4 PLC	±															
ANGLES	±															
MATERIAL		APPLICATION SPEC -	CAGE CODE 11139	DRAWING NO 3TXXXX-24/32-XXP/S												
FINISH		WEIGHT -	RESTRICTED TO													
<table border="0"> <tr> <td>8</td><td>9</td></tr> </table>		8	9	CUSTOMER DRAWING		SCALE 1:1 SHEET 1 OF 2 REV CI										
8	9															

4

3

2

1

THIS DRAWING IS UNPUBLISHED

RELEASED FOR PUBLICATION

2010

© COPYRIGHT 2010

BY - TE CONNECTIVITY

ALL RIGHTS RESERVED.

REVISIONS

P	LTR	DESCRIPTION	DATE	DWN	APVD
		SEE SHEET 1			

SIZE 24
RECOMMENDED PANEL CUTOUT

Technical drawing of a Size 24 recommended panel cutout. It shows a circular cutout with a diameter dimension of $\phi 1.640$ [41,66] and a width dimension of 1.525 [38,74].

SIZE 24
RECOMMENDED PANEL CUTOUT

Technical drawing of a Size 24 recommended panel cutout. It shows a circular cutout with a diameter dimension of $\phi 2.257$ [57,34] and a width dimension of 2.176 [55,27].

11. ENDBELL MOUNTING TORQUE:

- SIZE 24
124 \pm 17.7 in-lbf [14 \pm 2 Nm]
- SIZE 32
159.31 \pm 35.4 in-lbf [18 \pm 4 Nm]

10. PANEL NUT MOUNTING TORQUE:

- SIZE 24
361 \pm 60.2 in-lbf [40.8 \pm 6.8 Nm]
- SIZE 32
1625 \pm 120.4 in-lbf [183.6 \pm 13.6 Nm]

9. PLATING: CLEAR TRIVALENT CHROMATE CONVERSION COATING (ROHS COMPLIANT).

8. MATERIAL:
RECEPTACLE HOUSING: AL 6000 SERIES
GROMMET: VMQ (RED-ORANGE)
RETAINING RING: PA66 GF10
SOCKET FRONT: PA66 GF10 (BLACK)

NOTES: (CONTINUED)

THIS DRAWING IS A CONTROLLED DOCUMENT.

DIMENSIONS:
in [mm]

MATERIAL

8

TOLERANCES UNLESS OTHERWISE SPECIFIED:

0 PLC	\pm
1 PLC	\pm
2 PLC	\pm
3 PLC	$\pm .025$ [0.64]
4 PLC	\pm
ANGLES	\pm

FINISH

9

DWN 12/23/09

A. MALAGON

CHK 7/14/10

R. MILLIGAN

APVD 7/14/10

S. BEARD

PRODUCT SPEC

-

APPLICATION SPEC

-

WEIGHT

-

CUSTOMER DRAWING

NAME
RECEPTACLE CONNECTOR
SHELL SIZE 24 & 32
C.E. SERIES

SIZE	CAGE CODE	DRAWING NO	RESTRICTED TO
A3	11139	C-3TXXXX-24/32-XXP/S	

SCALE	1:1	SHEET	2 OF 2	REV	CI
-------	-----	-------	--------	-----	----

1470-19 (3/13)