



Circuit breaker size S0 for motor protection, CLASS 10 A-release 5.5...8 A N-release 104 A screw terminal Standard switching capacity with transverse auxiliary switches 1 NO+1 NC

product brand name	SIRIUS
product designation	Circuit breaker
design of the product	For motor protection
product type designation	3RV2
General technical data	
size of the circuit-breaker	S0
size of contactor can be combined company-specific	S00, S0
product extension auxiliary switch	Yes
power loss [W] for rated value of the current	
• at AC in hot operating state	9.25 W
• at AC in hot operating state per pole	3.1 W
insulation voltage with degree of pollution 3 at AC rated value	690 V
surge voltage resistance rated value	6 kV
shock resistance according to IEC 60068-2-27	25g / 11 ms
mechanical service life (operating cycles)	
• of the main contacts typical	100 000
• of auxiliary contacts typical	100 000
electrical endurance (operating cycles) typical	100 000
type of protection according to ATEX directive 2014/34/EU	Ex II (2) GD
certificate of suitability according to ATEX directive 2014/34/EU	DMT 02 ATEX F 001
reference code according to IEC 81346-2	Q
Substance Prohibitance (Date)	10/01/2009
SVHC substance name	Blei - 7439-92-1
Ambient conditions	
installation altitude at height above sea level maximum	2 000 m
ambient temperature	
• during operation	-20 ... +60 °C
• during storage	-50 ... +80 °C
• during transport	-50 ... +80 °C
relative humidity during operation	10 ... 95 %
Main circuit	
number of poles for main current circuit	3
adjustable current response value current of the current-dependent overload release	5.5 ... 8 A
operating voltage	
• rated value	20 ... 690 V
• at AC-3 rated value maximum	690 V
• at AC-3e rated value maximum	690 V
operating frequency rated value	50 ... 60 Hz
operational current rated value	8 A

operational current	
<ul style="list-style-type: none"> • at AC-3 at 400 V rated value • at AC-3e at 400 V rated value 	8 A 8 A
operating power	
<ul style="list-style-type: none"> • at AC-3 <ul style="list-style-type: none"> — at 230 V rated value — at 400 V rated value — at 500 V rated value — at 690 V rated value • at AC-3e <ul style="list-style-type: none"> — at 230 V rated value — at 400 V rated value — at 500 V rated value — at 690 V rated value 	1.5 kW 3 kW 4 kW 5.5 kW 1.5 kW 3 kW 4 kW 5.5 kW
operating frequency	
<ul style="list-style-type: none"> • at AC-3 maximum • at AC-3e maximum 	15 1/h 15 1/h
Auxiliary circuit	
design of the auxiliary switch	transverse
number of NC contacts for auxiliary contacts	
•	1
number of NO contacts for auxiliary contacts	
•	1
number of CO contacts for auxiliary contacts	0
operational current of auxiliary contacts at AC-15	
<ul style="list-style-type: none"> • at 24 V • at 120 V • at 125 V • at 230 V 	2 A 0.5 A 0.5 A 0.5 A
operational current of auxiliary contacts at DC-13	
<ul style="list-style-type: none"> • at 24 V • at 60 V 	1 A 0.15 A
Protective and monitoring functions	
product function	
<ul style="list-style-type: none"> • ground fault detection • phase failure detection 	No Yes
trip class	CLASS 10
design of the overload release	thermal
maximum short-circuit current breaking capacity (Icu)	
<ul style="list-style-type: none"> • at AC at 240 V rated value • at AC at 400 V rated value • at AC at 500 V rated value • at AC at 690 V rated value 	100 kA 100 kA 42 kA 6 kA
operating short-circuit current breaking capacity (Ics) at AC	
<ul style="list-style-type: none"> • at 240 V rated value • at 400 V rated value • at 500 V rated value • at 690 V rated value 	100 kA 100 kA 42 kA 4 kA
response value current of instantaneous short-circuit trip unit	104 A
UL/CSA ratings	
full-load current (FLA) for 3-phase AC motor	
<ul style="list-style-type: none"> • at 480 V rated value • at 600 V rated value 	8 A 8 A
yielded mechanical performance [hp]	
<ul style="list-style-type: none"> • for single-phase AC motor <ul style="list-style-type: none"> — at 110/120 V rated value — at 230 V rated value • for 3-phase AC motor <ul style="list-style-type: none"> — at 200/208 V rated value — at 220/230 V rated value 	0.33 hp 1 hp 2 hp 2 hp

— at 460/480 V rated value	5 hp
— at 575/600 V rated value	5 hp
contact rating of auxiliary contacts according to UL	C300 / R300
Short-circuit protection	
product function short circuit protection	Yes
design of the short-circuit trip	magnetic
design of the fuse link	Fuse gL/gG: 10 A, miniature circuit breaker C 6 A (short-circuit current $I_k < 400$ A)
• for short-circuit protection of the auxiliary switch required	
Installation/ mounting/ dimensions	
mounting position	any
fastening method	screw and snap-on mounting onto 35 mm DIN rail according to DIN EN 60715
height	97 mm
width	45 mm
depth	97 mm
required spacing	
• with side-by-side mounting at the side	
• for grounded parts at 400 V	
— downwards	
— upwards	
— at the side	
• for live parts at 400 V	
— downwards	
— upwards	
— at the side	
• for grounded parts at 500 V	
— downwards	
— upwards	
— at the side	
• for live parts at 500 V	
— downwards	
— upwards	
— at the side	
• for grounded parts at 690 V	
— downwards	
— upwards	
— backwards	
— at the side	
— forwards	
• for live parts at 690 V	
— downwards	
— upwards	
— backwards	
— at the side	
— forwards	
Connections/ Terminals	
type of electrical connection	screw-type terminals
• for main current circuit	
• for auxiliary and control circuit	screw-type terminals
arrangement of electrical connectors for main current circuit	Top and bottom
type of connectable conductor cross-sections	2x (1 ... 2.5 mm ²), 2x (2.5 ... 10 mm ²) 2x (1 ... 2.5 mm ²), 2x (2.5 ... 6 mm ²), 1x 10 mm ² 2x (16 ... 12), 2x (14 ... 8)
• for main contacts	
— solid or stranded	
— finely stranded with core end processing	
• for AWG cables for main contacts	
type of connectable conductor cross-sections	2x (0.5 ... 1.5 mm ²), 2x (0.75 ... 2.5 mm ²) 2x (0.5 ... 1.5 mm ²), 2x (0.75 ... 2.5 mm ²) 2x (20 ... 16), 2x (18 ... 14)
• for auxiliary contacts	
— solid or stranded	
— finely stranded with core end processing	
• for AWG cables for auxiliary contacts	

tightening torque	
<ul style="list-style-type: none"> for main contacts with screw-type terminals for auxiliary contacts with screw-type terminals 	2 ... 2.5 N·m 0.8 ... 1.2 N·m
design of screwdriver shaft	Diameter 5 to 6 mm
size of the screwdriver tip	Pozidriv size 2
design of the thread of the connection screw	
<ul style="list-style-type: none"> for main contacts of the auxiliary and control contacts 	M4 M3

Safety related data

proportion of dangerous failures	
<ul style="list-style-type: none"> with low demand rate according to SN 31920 with high demand rate according to SN 31920 	50 % 50 %
failure rate [FIT] with low demand rate according to SN 31920	50 FIT
B10 value with high demand rate according to SN 31920	5 000
IEC 61508	
T1 value for proof test interval or service life according to IEC 61508	10 a
Electrical Safety	
protection class IP on the front according to IEC 60529	IP20
touch protection on the front according to IEC 60529	finger-safe, for vertical contact from the front
display version for switching status	Handle

Approvals Certificates

General Product Approval



[Confirmation](#)



[KC](#)

General Product Approval	For use in hazardous locations	Test Certificates	Marine / Shipping
---------------------------------	---------------------------------------	--------------------------	--------------------------



[Type Test Certificates/Test Report](#)

[Special Test Certificate](#)



Marine / Shipping	other
--------------------------	--------------



[Miscellaneous](#)

other	Railway	Environment
--------------	----------------	--------------------

[Confirmation](#)



[Confirmation](#)

[EPD Typ II/III \(with life cycle assessment\)](#)

Further information

Information on the packaging

<https://support.industry.siemens.com/cs/ww/en/view/109813875>

Information- and Downloadcenter (Catalogs, Brochures,...)

<https://www.siemens.com/ic10>

Industry Mall (Online ordering system)

<https://mall.industry.siemens.com/mall/en/en/Catalog/product?mlfb=3RV2021-1HA15>

Cax online generator

<http://support.automation.siemens.com/WW/CAXorder/default.aspx?lang=en&mlfb=3RV2021-1HA15>

Service&Support (Manuals, Certificates, Characteristics, FAQs,...)

<https://support.industry.siemens.com/cs/ww/en/ps/3RV2021-1HA15>

Image database (product images, 2D dimension drawings, 3D models, device circuit diagrams, EPLAN macros, ...)

http://www.automation.siemens.com/bilddb/cax_de.aspx?mlfb=3RV2021-1HA15&lang=en

Characteristic: Tripping characteristics, I²t, Let-through current

<https://support.industry.siemens.com/cs/ww/en/ps/3RV2021-1HA15/char>

Further characteristics (e.g. electrical endurance, switching frequency)

<http://www.automation.siemens.com/bilddb/index.aspx?view=Search&mlfb=3RV2021-1HA15&objecttype=14&gridview=view1>

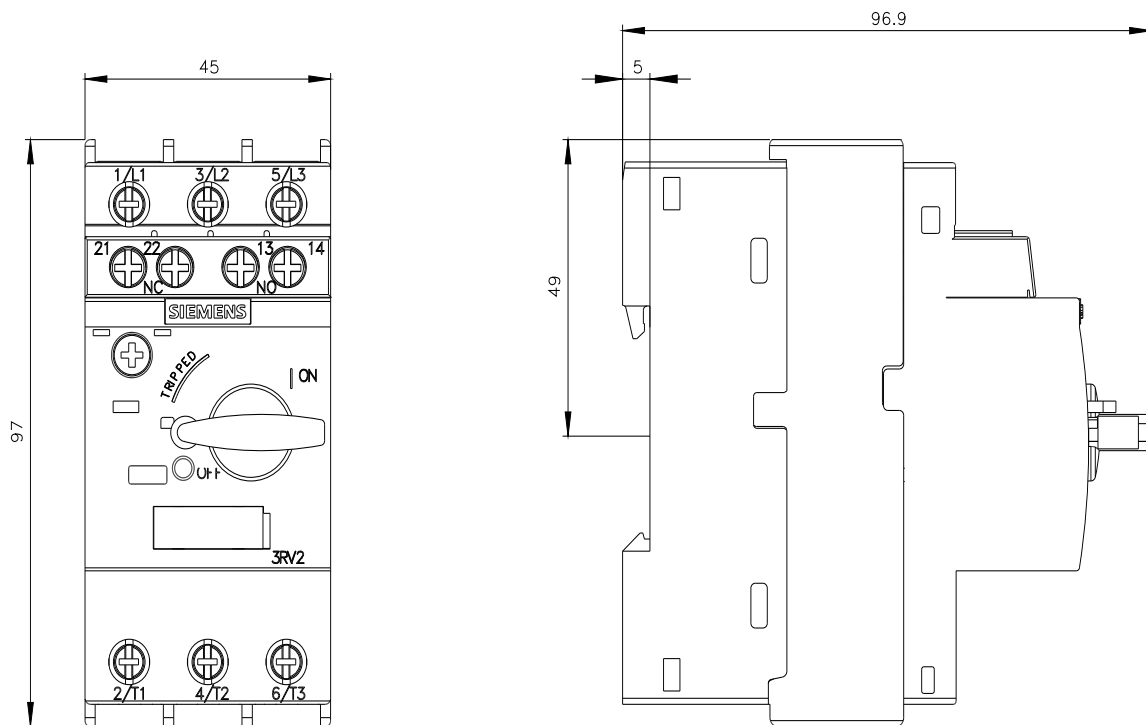

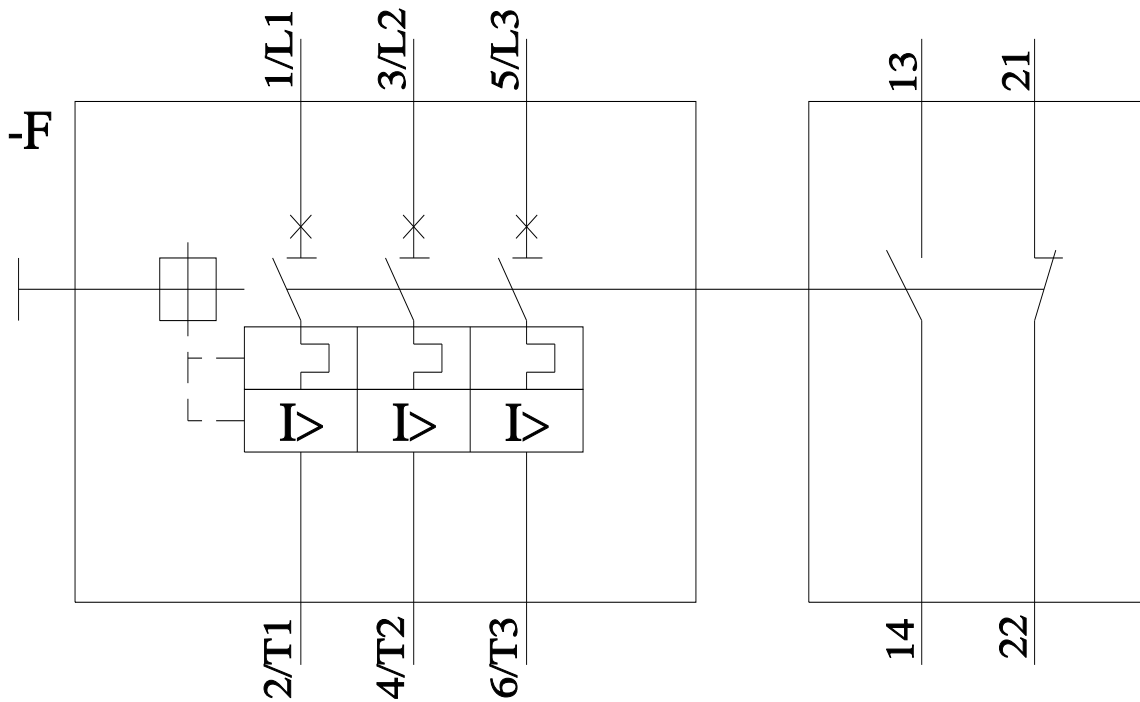
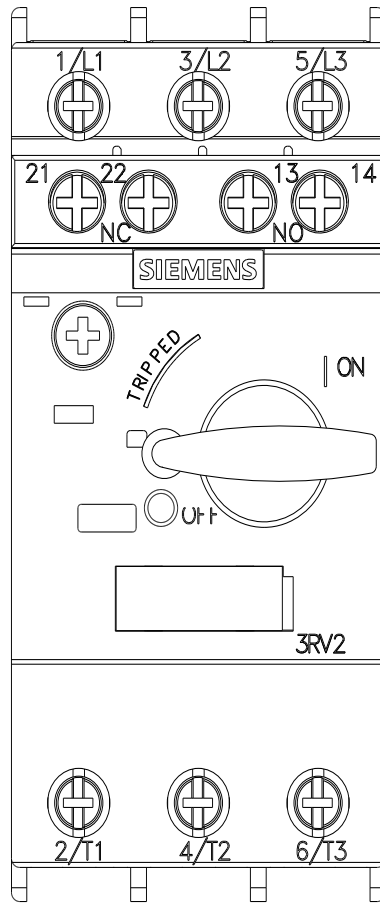

last modified:

9/1/2023