



Circuit breaker size S00 for motor protection, CLASS 10 A-release 1.4...2 A N-release 26 A screw terminal Standard switching capacity with transverse auxiliary switches 1 NO+1 NC

| | |
|---|----------------------|
| product brand name | SIRIUS |
| product designation | Circuit breaker |
| design of the product | For motor protection |
| product type designation | 3RV2 |
| General technical data | |
| size of the circuit-breaker | S00 |
| size of contactor can be combined company-specific | S00, S0 |
| product extension auxiliary switch | Yes |
| power loss [W] for rated value of the current | |
| • at AC in hot operating state | 7.25 W |
| • at AC in hot operating state per pole | 2.4 W |
| insulation voltage with degree of pollution 3 at AC rated value | 690 V |
| surge voltage resistance rated value | 6 kV |
| shock resistance according to IEC 60068-2-27 | 25g / 11 ms |
| mechanical service life (operating cycles) | |
| • of the main contacts typical | 100 000 |
| • of auxiliary contacts typical | 100 000 |
| electrical endurance (operating cycles) typical | 100 000 |
| type of protection according to ATEX directive 2014/34/EU | Ex II (2) GD |
| certificate of suitability according to ATEX directive 2014/34/EU | DMT 02 ATEX F 001 |
| reference code according to IEC 81346-2 | Q |
| Substance Prohibitance (Date) | 10/01/2009 |
| SVHC substance name | Blei - 7439-92-1 |
| Ambient conditions | |
| installation altitude at height above sea level maximum | 2 000 m |
| ambient temperature | |
| • during operation | -20 ... +60 °C |
| • during storage | -50 ... +80 °C |
| • during transport | -50 ... +80 °C |
| relative humidity during operation | 10 ... 95 % |
| Main circuit | |
| number of poles for main current circuit | 3 |
| adjustable current response value current of the current-dependent overload release | 1.4 ... 2 A |
| operating voltage | |
| • rated value | 20 ... 690 V |
| • at AC-3 rated value maximum | 690 V |
| • at AC-3e rated value maximum | 690 V |
| operating frequency rated value | 50 ... 60 Hz |
| operational current rated value | 2 A |

| | |
|---|--|
| operational current | |
| <ul style="list-style-type: none"> at AC-3 at 400 V rated value at AC-3e at 400 V rated value | 2 A 2 A |
| operating power | |
| <ul style="list-style-type: none"> at AC-3 <ul style="list-style-type: none"> at 230 V rated value at 400 V rated value at 500 V rated value at 690 V rated value at AC-3e <ul style="list-style-type: none"> at 230 V rated value at 400 V rated value at 500 V rated value at 690 V rated value | 0.4 kW 0.75 kW 0.8 kW 1.1 kW 0.4 kW 0.75 kW 0.8 kW 1.1 kW |
| operating frequency | |
| <ul style="list-style-type: none"> at AC-3 maximum at AC-3e maximum | 15 1/h 15 1/h |
| Auxiliary circuit | |
| design of the auxiliary switch | transverse |
| number of NC contacts for auxiliary contacts | |
| <ul style="list-style-type: none"> | 1 |
| number of NO contacts for auxiliary contacts | |
| <ul style="list-style-type: none"> | 1 |
| number of CO contacts for auxiliary contacts | 0 |
| operational current of auxiliary contacts at AC-15 | |
| <ul style="list-style-type: none"> at 24 V at 120 V at 125 V at 230 V | 2 A 0.5 A 0.5 A 0.5 A |
| operational current of auxiliary contacts at DC-13 | |
| <ul style="list-style-type: none"> at 24 V at 60 V | 1 A 0.15 A |
| Protective and monitoring functions | |
| product function | |
| <ul style="list-style-type: none"> ground fault detection phase failure detection | No Yes |
| trip class | CLASS 10 |
| design of the overload release | thermal |
| maximum short-circuit current breaking capacity (I_{cu}) | |
| <ul style="list-style-type: none"> at AC at 240 V rated value at AC at 400 V rated value at AC at 500 V rated value at AC at 690 V rated value | 100 kA 100 kA 100 kA 10 kA |
| operating short-circuit current breaking capacity (I_{cs}) at AC | |
| <ul style="list-style-type: none"> at 240 V rated value at 400 V rated value at 500 V rated value at 690 V rated value | 100 kA 100 kA 100 kA 10 kA |
| response value current of instantaneous short-circuit trip unit | 26 A |
| UL/CSA ratings | |
| full-load current (FLA) for 3-phase AC motor | |
| <ul style="list-style-type: none"> at 480 V rated value at 600 V rated value | 2 A 2 A |
| yielded mechanical performance [hp] | |
| <ul style="list-style-type: none"> for single-phase AC motor <ul style="list-style-type: none"> at 230 V rated value for 3-phase AC motor <ul style="list-style-type: none"> at 460/480 V rated value at 575/600 V rated value | 0.13 hp 1 hp 1 hp |
| contact rating of auxiliary contacts according to UL | C300 / R300 |

| Short-circuit protection | |
|---|--|
| product function short circuit protection | Yes |
| design of the short-circuit trip | magnetic |
| design of the fuse link <ul style="list-style-type: none"> for short-circuit protection of the auxiliary switch required | Fuse gL/gG: 10 A, miniature circuit breaker C 6 A (short-circuit current $I_k < 400$ A) |
| design of the fuse link for IT network for short-circuit protection of the main circuit <ul style="list-style-type: none"> at 400 V at 500 V at 690 V | gL/gG 25 A gL/gG 25 A gL/gG 20 A |
| Installation/ mounting/ dimensions | |
| mounting position | any |
| fastening method | screw and snap-on mounting onto 35 mm DIN rail according to DIN EN 60715 |
| height | 97 mm |
| width | 45 mm |
| depth | 97 mm |
| required spacing <ul style="list-style-type: none"> with side-by-side mounting at the side for grounded parts at 400 V <ul style="list-style-type: none"> downwards upwards at the side for live parts at 400 V <ul style="list-style-type: none"> downwards upwards at the side for grounded parts at 500 V <ul style="list-style-type: none"> downwards upwards at the side for live parts at 500 V <ul style="list-style-type: none"> downwards upwards at the side for grounded parts at 690 V <ul style="list-style-type: none"> downwards upwards backwards at the side forwards for live parts at 690 V <ul style="list-style-type: none"> downwards upwards backwards at the side forwards | 0 mm 30 mm 30 mm 9 mm 30 mm 30 mm 9 mm 30 mm 30 mm 9 mm 50 mm 50 mm 0 mm 30 mm 0 mm 50 mm 50 mm 0 mm 30 mm 0 mm |
| Connections/ Terminals | |
| type of electrical connection <ul style="list-style-type: none"> for main current circuit for auxiliary and control circuit | screw-type terminals screw-type terminals |
| arrangement of electrical connectors for main current circuit | Top and bottom |
| type of connectable conductor cross-sections <ul style="list-style-type: none"> for main contacts <ul style="list-style-type: none"> solid or stranded finely stranded with core end processing for AWG cables for main contacts | 2x (0,75 ... 2,5 mm ²), 2x 4 mm ² 2x (0.5 ... 1.5 mm ²), 2x (0.75 ... 2.5 mm ²) 2x (18 ... 14), 2x 12 |
| type of connectable conductor cross-sections <ul style="list-style-type: none"> for auxiliary contacts <ul style="list-style-type: none"> solid or stranded | 2x (0.5 ... 1.5 mm ²), 2x (0.75 ... 2.5 mm ²) |

| | |
|---|---|
| — finely stranded with core end processing | 2x (0.5 ... 1.5 mm ²), 2x (0.75 ... 2.5 mm ²) |
| • for AWG cables for auxiliary contacts | 2x (20 ... 16), 2x (18 ... 14) |
| tightening torque | |
| • for main contacts with screw-type terminals | 0.8 ... 1.2 N·m |
| • for auxiliary contacts with screw-type terminals | 0.8 ... 1.2 N·m |
| design of screwdriver shaft | Diameter 5 to 6 mm |
| size of the screwdriver tip | Pozidriv size 2 |
| design of the thread of the connection screw | |
| • for main contacts | M3 |
| • of the auxiliary and control contacts | M3 |

Safety related data

| | |
|--|--------|
| proportion of dangerous failures | |
| • with low demand rate according to SN 31920 | 50 % |
| • with high demand rate according to SN 31920 | 50 % |
| failure rate [FIT] with low demand rate according to SN 31920 | 50 FIT |
| B10 value with high demand rate according to SN 31920 | 5 000 |
| IEC 61508 | |
| T1 value for proof test interval or service life according to IEC 61508 | 10 a |

Electrical Safety

| | |
|--|--|
| protection class IP on the front according to IEC 60529 | IP20 |
| touch protection on the front according to IEC 60529 | finger-safe, for vertical contact from the front |
| display version for switching status | Handle |

Approvals Certificates

General Product Approval



[Confirmation](#)



[KC](#)

| | | | |
|--------------------------|--------------------------------|-------------------|-------------------|
| General Product Approval | For use in hazardous locations | Test Certificates | Marine / Shipping |
|--------------------------|--------------------------------|-------------------|-------------------|



[Type Test Certificates/Test Report](#)

[Special Test Certificate](#)



| | |
|-------------------|-------|
| Marine / Shipping | other |
|-------------------|-------|



[Miscellaneous](#)

| | | |
|-------|---------|-------------|
| other | Railway | Environment |
|-------|---------|-------------|

[Confirmation](#)



[Confirmation](#)

[EPD Typ II/III \(with life cycle assessment\)](#)

Further information

Information on the packaging

<https://support.industry.siemens.com/cs/ww/en/view/109813875>

Information- and Downloadcenter (Catalogs, Brochures,...)

<https://www.siemens.com/ic10>

Industry Mall (Online ordering system)

<https://mall.industry.siemens.com/mall/en/en/Catalog/product?mlfb=3RV2011-1BA15>

Cax online generator

<http://support.automation.siemens.com/WW/CAXorder/default.aspx?lang=en&mlfb=3RV2011-1BA15>

Service&Support (Manuals, Certificates, Characteristics, FAQs,...)

<https://support.industry.siemens.com/cs/ww/en/ps/3RV2011-1BA15>

Image database (product images, 2D dimension drawings, 3D models, device circuit diagrams, EPLAN macros, ...)

http://www.automation.siemens.com/bilddb/cax_de.aspx?mlfb=3RV2011-1BA15&lang=en

Characteristic: Tripping characteristics, I²t, Let-through current

<https://support.industry.siemens.com/cs/ww/en/ps/3RV2011-1BA15/char>

Further characteristics (e.g. electrical endurance, switching frequency)

<http://www.automation.siemens.com/bilddb/index.aspx?view=Search&mlfb=3RV2011-1BA15&objecttype=14&gridview=view1>

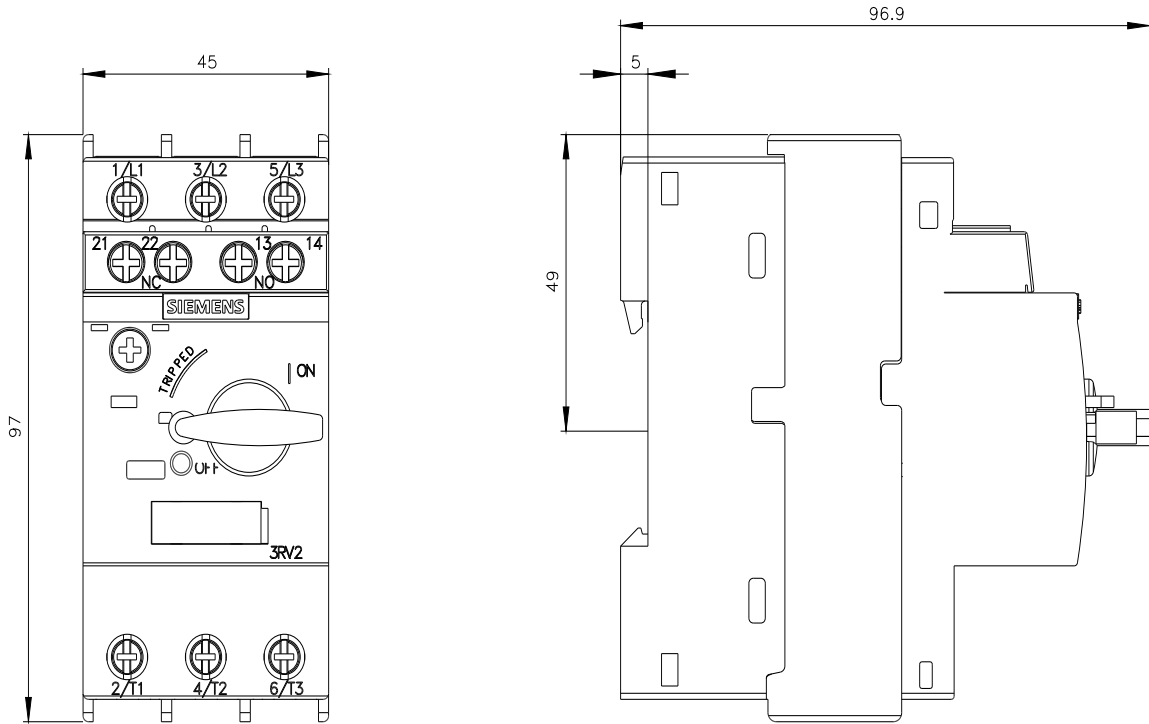

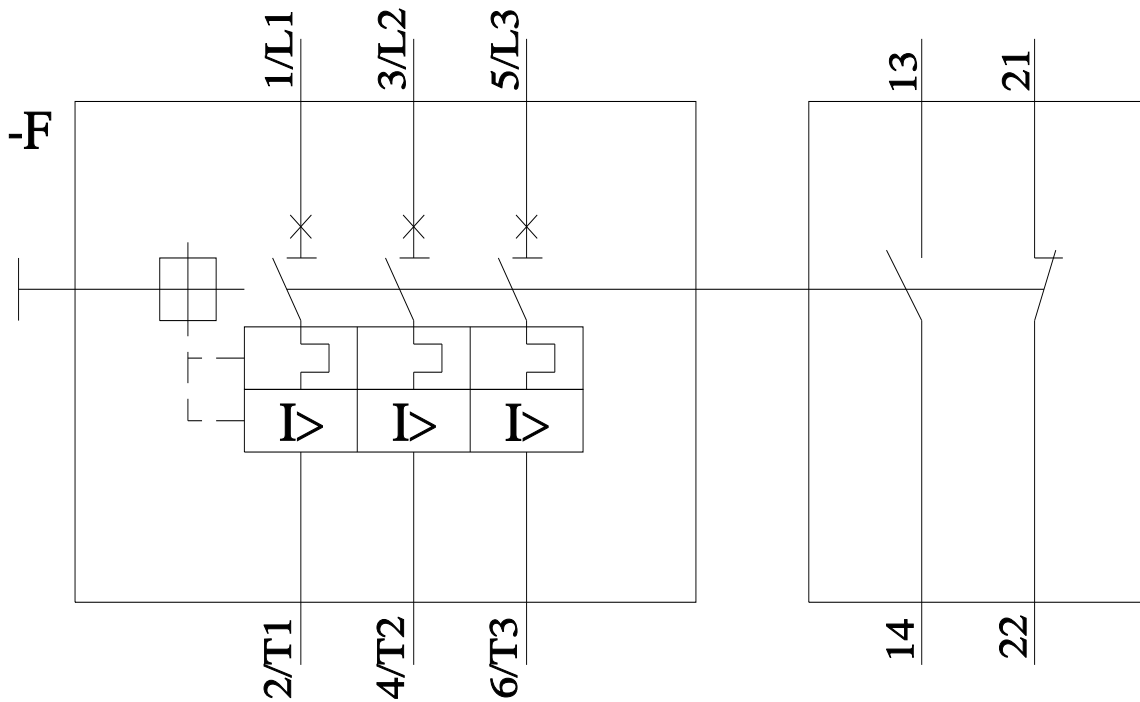

last modified:

8/29/2023