



Circuit breaker size S00 for motor protection, CLASS 10 A-release 1.1...1.6 A N-release 21 A screw terminal Standard switching capacity with transverse auxiliary switches 1 NO+1 NC

<b>product brand name</b>	SIRIUS
<b>product designation</b>	Circuit breaker
<b>design of the product</b>	For motor protection
<b>product type designation</b>	3RV2
<b>General technical data</b>	
<b>size of the circuit-breaker</b>	S00
<b>size of contactor can be combined company-specific</b>	S00, S0
product extension auxiliary switch	Yes
<b>power loss [W] for rated value of the current</b>	
• at AC in hot operating state	7.25 W
• at AC in hot operating state per pole	2.4 W
insulation voltage with degree of pollution 3 at AC rated value	690 V
<b>surge voltage resistance rated value</b>	6 kV
<b>shock resistance according to IEC 60068-2-27</b>	25g / 11 ms
<b>mechanical service life (operating cycles)</b>	
• of the main contacts typical	100 000
• of auxiliary contacts typical	100 000
electrical endurance (operating cycles) typical	100 000
<b>type of protection according to ATEX directive 2014/34/EU</b>	Ex II (2) GD
certificate of suitability according to ATEX directive 2014/34/EU	DMT 02 ATEX F 001
<b>reference code according to IEC 81346-2</b>	Q
<b>Substance Prohibitance (Date)</b>	10/01/2009
<b>SVHC substance name</b>	Blei - 7439-92-1
<b>Ambient conditions</b>	
installation altitude at height above sea level maximum	2 000 m
<b>ambient temperature</b>	
• during operation	-20 ... +60 °C
• during storage	-50 ... +80 °C
• during transport	-50 ... +80 °C
relative humidity during operation	10 ... 95 %
<b>Main circuit</b>	
<b>number of poles for main current circuit</b>	3
<b>adjustable current response value current of the current-dependent overload release</b>	1.1 ... 1.6 A
<b>operating voltage</b>	
• rated value	20 ... 690 V
• at AC-3 rated value maximum	690 V
• at AC-3e rated value maximum	690 V
<b>operating frequency rated value</b>	50 ... 60 Hz
<b>operational current rated value</b>	1.6 A

<b>operational current</b>	
<ul style="list-style-type: none"> <li>at AC-3 at 400 V rated value</li> <li>at AC-3e at 400 V rated value</li> </ul>	1.6 A 1.6 A
<b>operating power</b>	
<ul style="list-style-type: none"> <li>at AC-3 <ul style="list-style-type: none"> <li>at 230 V rated value</li> <li>at 400 V rated value</li> <li>at 500 V rated value</li> <li>at 690 V rated value</li> </ul> </li> <li>at AC-3e <ul style="list-style-type: none"> <li>at 230 V rated value</li> <li>at 400 V rated value</li> <li>at 500 V rated value</li> <li>at 690 V rated value</li> </ul> </li> </ul>	0.3 kW 0.55 kW 0.8 kW 1.1 kW 0.3 kW 0.55 kW 0.8 kW 1.1 kW
<b>operating frequency</b>	
<ul style="list-style-type: none"> <li>at AC-3 maximum</li> <li>at AC-3e maximum</li> </ul>	15 1/h 15 1/h
<b>Auxiliary circuit</b>	
<b>design of the auxiliary switch</b>	transverse
<b>number of NC contacts for auxiliary contacts</b>	
<ul style="list-style-type: none"> <li></li> </ul>	1
number of NO contacts for auxiliary contacts	
<ul style="list-style-type: none"> <li></li> </ul>	1
number of CO contacts for auxiliary contacts	0
<b>operational current of auxiliary contacts at AC-15</b>	
<ul style="list-style-type: none"> <li>at 24 V</li> <li>at 120 V</li> <li>at 125 V</li> <li>at 230 V</li> </ul>	2 A 0.5 A 0.5 A 0.5 A
<b>operational current of auxiliary contacts at DC-13</b>	
<ul style="list-style-type: none"> <li>at 24 V</li> <li>at 60 V</li> </ul>	1 A 0.15 A
<b>Protective and monitoring functions</b>	
<b>product function</b>	
<ul style="list-style-type: none"> <li>ground fault detection</li> <li>phase failure detection</li> </ul>	No Yes
<b>trip class</b>	CLASS 10
<b>design of the overload release</b>	thermal
<b>maximum short-circuit current breaking capacity (Icu)</b>	
<ul style="list-style-type: none"> <li>at AC at 240 V rated value</li> <li>at AC at 400 V rated value</li> <li>at AC at 500 V rated value</li> <li>at AC at 690 V rated value</li> </ul>	100 kA 100 kA 100 kA 100 kA
<b>operating short-circuit current breaking capacity (Ics) at AC</b>	
<ul style="list-style-type: none"> <li>at 240 V rated value</li> <li>at 400 V rated value</li> <li>at 500 V rated value</li> <li>at 690 V rated value</li> </ul>	100 kA 100 kA 100 kA 100 kA
response value current of instantaneous short-circuit trip unit	21 A
<b>UL/CSA ratings</b>	
<b>full-load current (FLA) for 3-phase AC motor</b>	
<ul style="list-style-type: none"> <li>at 480 V rated value</li> <li>at 600 V rated value</li> </ul>	1.6 A 1.6 A
<b>yielded mechanical performance [hp]</b>	
<ul style="list-style-type: none"> <li>for single-phase AC motor <ul style="list-style-type: none"> <li>at 230 V rated value</li> </ul> </li> <li>for 3-phase AC motor <ul style="list-style-type: none"> <li>at 460/480 V rated value</li> <li>at 575/600 V rated value</li> </ul> </li> </ul>	0.1 hp 1 hp 0.8 hp
<b>contact rating of auxiliary contacts according to UL</b>	C300 / R300

Short-circuit protection	
<b>product function short circuit protection</b>	Yes
<b>design of the short-circuit trip</b>	magnetic
<b>design of the fuse link</b> <ul style="list-style-type: none"> <li>for short-circuit protection of the auxiliary switch required</li> </ul>	Fuse gL/gG: 10 A, miniature circuit breaker C 6 A (short-circuit current $I_k < 400$ A)
<b>design of the fuse link for IT network for short-circuit protection of the main circuit</b> <ul style="list-style-type: none"> <li>at 500 V</li> <li>at 690 V</li> </ul>	gL/gG 20 A gL/gG 16 A
Installation/ mounting/ dimensions	
<b>mounting position</b>	any
<b>fastening method</b>	screw and snap-on mounting onto 35 mm DIN rail according to DIN EN 60715
<b>height</b>	97 mm
<b>width</b>	45 mm
<b>depth</b>	97 mm
<b>required spacing</b> <ul style="list-style-type: none"> <li>with side-by-side mounting at the side</li> <li>for grounded parts at 400 V <ul style="list-style-type: none"> <li>downwards</li> <li>upwards</li> <li>at the side</li> </ul> </li> <li>for live parts at 400 V <ul style="list-style-type: none"> <li>downwards</li> <li>upwards</li> <li>at the side</li> </ul> </li> <li>for grounded parts at 500 V <ul style="list-style-type: none"> <li>downwards</li> <li>upwards</li> <li>at the side</li> </ul> </li> <li>for live parts at 500 V <ul style="list-style-type: none"> <li>downwards</li> <li>upwards</li> <li>at the side</li> </ul> </li> <li>for grounded parts at 690 V <ul style="list-style-type: none"> <li>downwards</li> <li>upwards</li> <li>backwards</li> <li>at the side</li> <li>forwards</li> </ul> </li> <li>for live parts at 690 V <ul style="list-style-type: none"> <li>downwards</li> <li>upwards</li> <li>backwards</li> <li>at the side</li> <li>forwards</li> </ul> </li> </ul>	0 mm 30 mm 30 mm 9 mm 30 mm 30 mm 9 mm 30 mm 30 mm 9 mm 50 mm 50 mm 0 mm 30 mm 0 mm 50 mm 50 mm 0 mm 30 mm 0 mm
Connections/ Terminals	
<b>type of electrical connection</b> <ul style="list-style-type: none"> <li>for main current circuit</li> <li>for auxiliary and control circuit</li> </ul>	screw-type terminals screw-type terminals
<b>arrangement of electrical connectors for main current circuit</b>	Top and bottom
<b>type of connectable conductor cross-sections</b> <ul style="list-style-type: none"> <li>for main contacts <ul style="list-style-type: none"> <li>solid or stranded</li> <li>finely stranded with core end processing</li> </ul> </li> <li>for AWG cables for main contacts</li> </ul>	2x (0,75 ... 2,5 mm <sup>2</sup> ), 2x 4 mm <sup>2</sup> 2x (0.5 ... 1.5 mm <sup>2</sup> ), 2x (0.75 ... 2.5 mm <sup>2</sup> ) 2x (18 ... 14), 2x 12
<b>type of connectable conductor cross-sections</b> <ul style="list-style-type: none"> <li>for auxiliary contacts <ul style="list-style-type: none"> <li>solid or stranded</li> <li>finely stranded with core end processing</li> </ul> </li> </ul>	2x (0.5 ... 1.5 mm <sup>2</sup> ), 2x (0.75 ... 2.5 mm <sup>2</sup> ) 2x (0.5 ... 1.5 mm <sup>2</sup> ), 2x (0.75 ... 2.5 mm <sup>2</sup> )

<ul style="list-style-type: none"> <li>for AWG cables for auxiliary contacts</li> </ul>	2x (20 ... 16), 2x (18 ... 14)
<b>tightening torque</b>	
<ul style="list-style-type: none"> <li>for main contacts with screw-type terminals</li> </ul>	0.8 ... 1.2 N·m
<ul style="list-style-type: none"> <li>for auxiliary contacts with screw-type terminals</li> </ul>	0.8 ... 1.2 N·m
<b>design of screwdriver shaft</b>	Diameter 5 to 6 mm
<b>size of the screwdriver tip</b>	Pozidriv size 2
<b>design of the thread of the connection screw</b>	
<ul style="list-style-type: none"> <li>for main contacts</li> </ul>	M3
<ul style="list-style-type: none"> <li>of the auxiliary and control contacts</li> </ul>	M3

### Safety related data

<b>proportion of dangerous failures</b>	
<ul style="list-style-type: none"> <li>with low demand rate according to SN 31920</li> </ul>	50 %
<ul style="list-style-type: none"> <li>with high demand rate according to SN 31920</li> </ul>	50 %
<b>failure rate [FIT] with low demand rate according to SN 31920</b>	50 FIT
<b>B10 value with high demand rate according to SN 31920</b>	5 000

IEC 61508	
<b>T1 value for proof test interval or service life according to IEC 61508</b>	10 a

Electrical Safety	
<b>protection class IP on the front according to IEC 60529</b>	IP20
<b>touch protection on the front according to IEC 60529</b>	finger-safe, for vertical contact from the front
display version for switching status	Handle

### Approvals Certificates

#### General Product Approval



[Confirmation](#)



[KC](#)

General Product Approval	For use in hazardous locations	Test Certificates	Marine / Shipping
--------------------------	--------------------------------	-------------------	-------------------



[Type Test Certificates/Test Report](#)

[Special Test Certificate](#)



Marine / Shipping	other
-------------------	-------



[Miscellaneous](#)

other	Railway	Environment
-------	---------	-------------

[Confirmation](#)



[Confirmation](#)

[EPD Typ II/III \(with life cycle assessment\)](#)

### Further information

#### Information on the packaging

<https://support.industry.siemens.com/cs/ww/en/view/109813875>

Information- and Downloadcenter (Catalogs, Brochures,...)

<https://www.siemens.com/ic10>

Industry Mall (Online ordering system)

<https://mall.industry.siemens.com/mall/en/en/Catalog/product?mlfb=3RV2011-1AA15>

Cax online generator

<http://support.automation.siemens.com/WW/CAXorder/default.aspx?lang=en&mlfb=3RV2011-1AA15>

Service&Support (Manuals, Certificates, Characteristics, FAQs,...)

<https://support.industry.siemens.com/cs/ww/en/ps/3RV2011-1AA15>

Image database (product images, 2D dimension drawings, 3D models, device circuit diagrams, EPLAN macros, ...)

[http://www.automation.siemens.com/bilddb/cax\\_de.aspx?mlfb=3RV2011-1AA15&lang=en](http://www.automation.siemens.com/bilddb/cax_de.aspx?mlfb=3RV2011-1AA15&lang=en)

Characteristic: Tripping characteristics,  $I^2t$ , Let-through current

<https://support.industry.siemens.com/cs/ww/en/ps/3RV2011-1AA15/char>

Further characteristics (e.g. electrical endurance, switching frequency)

<http://www.automation.siemens.com/bilddb/index.aspx?view=Search&mlfb=3RV2011-1AA15&objecttype=14&gridview=view1>

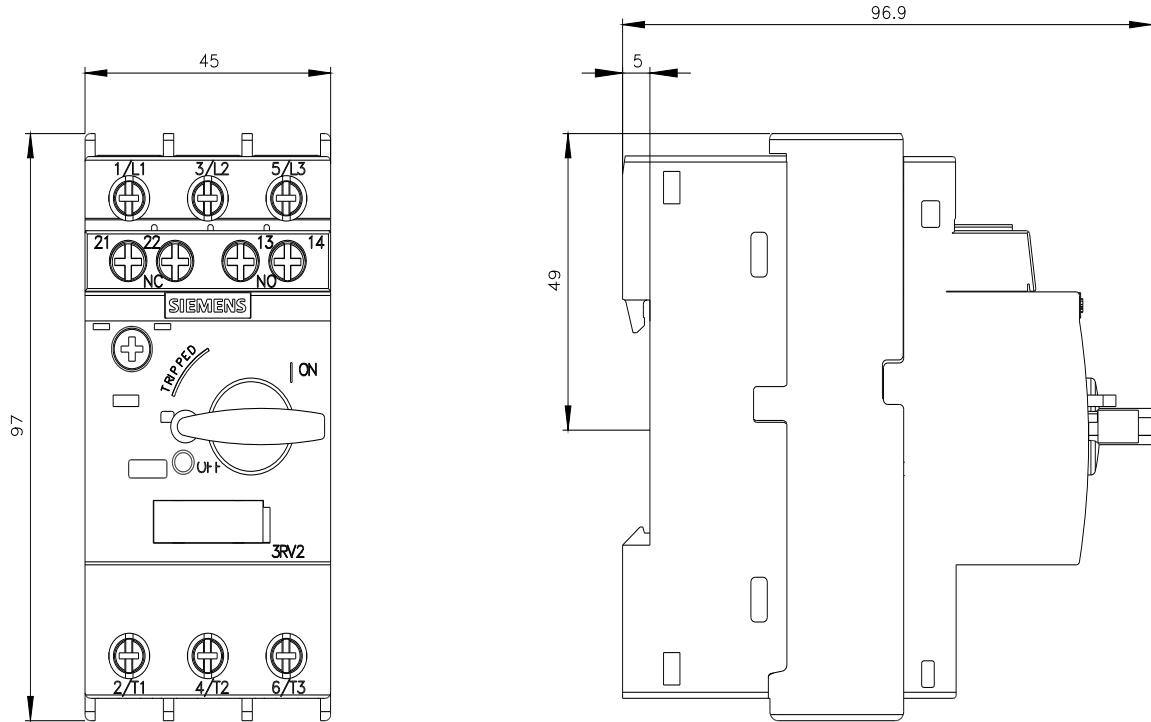

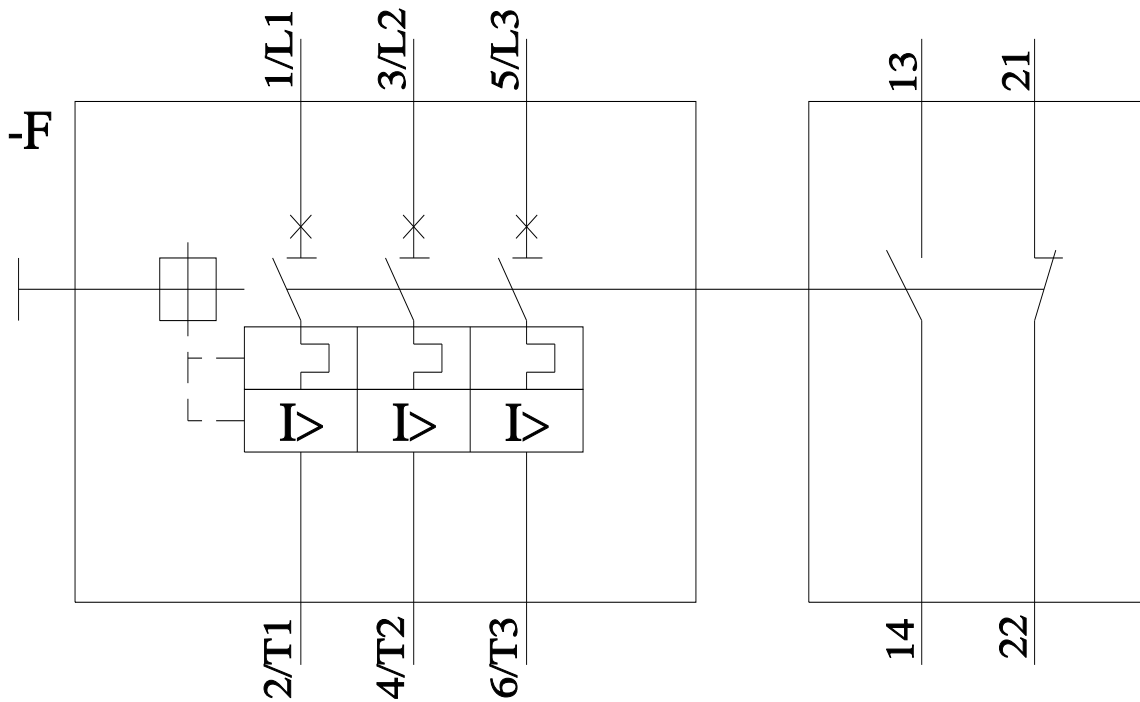

last modified:

8/29/2023