

power contactor, AC-3 25 A, 11 kW / 400 V 1 NO + 1 NC, 24 V DC 3-pole, Size S0 screw terminal



product brand name	SIRIUS
product designation	Power contactor
product type designation	3RT2

General technical data	
size of contactor	S0
product extension	
<ul style="list-style-type: none"> function module for communication 	No
<ul style="list-style-type: none"> auxiliary switch 	Yes
power loss [W] for rated value of the current	
<ul style="list-style-type: none"> at AC in hot operating state 	4.8 W
<ul style="list-style-type: none"> at AC in hot operating state per pole 	1.6 W
power loss [W] for rated value of the current without load current share typical	5.9 W
surge voltage resistance	
<ul style="list-style-type: none"> of main circuit rated value 	6 kV
<ul style="list-style-type: none"> of auxiliary circuit rated value 	6 kV
maximum permissible voltage for safe isolation	
<ul style="list-style-type: none"> between coil and main contacts acc. to EN 60947-1 	400 V

protection class IP	
<ul style="list-style-type: none"> • on the front • of the terminal 	IP20 IP20
shock resistance at rectangular impulse	
<ul style="list-style-type: none"> • at DC 	10g / 5 ms, 7,5g / 10 ms
shock resistance with sine pulse	
<ul style="list-style-type: none"> • at DC 	15g / 5 ms, 10g / 10 ms
mechanical service life (switching cycles)	
<ul style="list-style-type: none"> • of contactor typical 	10 000 000
<ul style="list-style-type: none"> • of the contactor with added electronically optimized auxiliary switch block typical 	5 000 000
<ul style="list-style-type: none"> • of the contactor with added auxiliary switch block typical 	10 000 000
reference code acc. to IEC 81346-2	Q

Ambient conditions	
<ul style="list-style-type: none"> • installation altitude at height above sea level maximum 	2 000 m
ambient temperature	
<ul style="list-style-type: none"> • during operation • during storage 	-25 ... +60 °C -55 ... +80 °C

Main circuit	
number of poles for main current circuit	3
number of NO contacts for main contacts	3
operating voltage	
<ul style="list-style-type: none"> • at AC-3 rated value maximum 	690 V
operational current	
<ul style="list-style-type: none"> • at AC-1 at 400 V <ul style="list-style-type: none"> — at ambient temperature 40 °C rated value 	40 A
<ul style="list-style-type: none"> • at AC-1 <ul style="list-style-type: none"> — up to 690 V at ambient temperature 40 °C rated value — up to 690 V at ambient temperature 60 °C rated value 	40 A 35 A
<ul style="list-style-type: none"> • at AC-3 <ul style="list-style-type: none"> — at 400 V rated value — at 500 V rated value — at 690 V rated value 	25 A 18 A 13 A
<ul style="list-style-type: none"> • at AC-4 at 400 V rated value 	15.5 A
<ul style="list-style-type: none"> • at AC-5a up to 690 V rated value 	35.2 A
<ul style="list-style-type: none"> • at AC-5b up to 400 V rated value 	20.7 A
<ul style="list-style-type: none"> • at AC-6a 	

— up to 230 V for current peak value n=20 rated value	20.2 A
— up to 400 V for current peak value n=20 rated value	20.2 A
— up to 500 V for current peak value n=20 rated value	20.2 A
— up to 690 V for current peak value n=20 rated value	12.9 A
• at AC-6a	
— up to 230 V for current peak value n=30 rated value	13.5 A
— up to 400 V for current peak value n=30 rated value	13.5 A
— up to 500 V for current peak value n=30 rated value	13.5 A
— up to 690 V for current peak value n=30 rated value	13 A
minimum cross-section in main circuit	
• at maximum AC-1 rated value	10 mm ²
operational current for approx. 200000 operating cycles at AC-4	
• at 400 V rated value	9 A
• at 690 V rated value	9 A
operational current	
• at 1 current path at DC-1	
— at 24 V rated value	35 A
— at 110 V rated value	4.5 A
— at 220 V rated value	1 A
— at 440 V rated value	0.4 A
— at 600 V rated value	0.25 A
• with 2 current paths in series at DC-1	
— at 24 V rated value	35 A
— at 110 V rated value	35 A
— at 220 V rated value	5 A
— at 440 V rated value	1 A
— at 600 V rated value	0.8 A
• with 3 current paths in series at DC-1	
— at 24 V rated value	35 A
— at 110 V rated value	35 A
— at 220 V rated value	35 A
— at 440 V rated value	2.9 A
— at 600 V rated value	1.4 A
operational current	

<ul style="list-style-type: none"> • at 1 current path at DC-3 at DC-5 <ul style="list-style-type: none"> — at 24 V rated value — at 110 V rated value — at 220 V rated value — at 440 V rated value — at 600 V rated value • with 2 current paths in series at DC-3 at DC-5 <ul style="list-style-type: none"> — at 24 V rated value — at 110 V rated value — at 220 V rated value — at 440 V rated value — at 600 V rated value • with 3 current paths in series at DC-3 at DC-5 <ul style="list-style-type: none"> — at 24 V rated value — at 110 V rated value — at 220 V rated value — at 440 V rated value — at 600 V rated value 	<p>20 A</p> <p>2.5 A</p> <p>1 A</p> <p>0.09 A</p> <p>0.06 A</p> <p>35 A</p> <p>15 A</p> <p>3 A</p> <p>0.27 A</p> <p>0.16 A</p> <p>35 A</p> <p>35 A</p> <p>10 A</p> <p>0.6 A</p> <p>0.6 A</p>
operating power	
<ul style="list-style-type: none"> • at AC-3 <ul style="list-style-type: none"> — at 230 V rated value — at 400 V rated value — at 500 V rated value — at 690 V rated value 	<p>5.5 kW</p> <p>11 kW</p> <p>11 kW</p> <p>11 kW</p>
operating power for approx. 200000 operating cycles at AC-4	
<ul style="list-style-type: none"> • at 400 V rated value • at 690 V rated value 	<p>4.4 kW</p> <p>7.7 kW</p>
operating apparent power at AC-6a	
<ul style="list-style-type: none"> • up to 230 V for current peak value n=20 rated value • up to 400 V for current peak value n=20 rated value • up to 500 V for current peak value n=20 rated value • up to 690 V for current peak value n=20 rated value 	<p>8 kV·A</p> <p>13.9 kV·A</p> <p>17.4 kV·A</p> <p>15.4 kV·A</p>
operating apparent power at AC-6a	
<ul style="list-style-type: none"> • up to 230 V for current peak value n=30 rated value • up to 400 V for current peak value n=30 rated value 	<p>5.3 kV·A</p> <p>9.3 kV·A</p>

<ul style="list-style-type: none"> • up to 500 V for current peak value n=30 rated value 	11.6 kV·A
<ul style="list-style-type: none"> • up to 690 V for current peak value n=30 rated value 	15.5 kV·A
short-time withstand current in cold operating state up to 40 °C	
<ul style="list-style-type: none"> • limited to 1 s switching at zero current maximum 	375 A; Use minimum cross-section acc. to AC-1 rated value
<ul style="list-style-type: none"> • limited to 5 s switching at zero current maximum 	299 A; Use minimum cross-section acc. to AC-1 rated value
<ul style="list-style-type: none"> • limited to 10 s switching at zero current maximum 	200 A; Use minimum cross-section acc. to AC-1 rated value
<ul style="list-style-type: none"> • limited to 30 s switching at zero current maximum 	128 A; Use minimum cross-section acc. to AC-1 rated value
<ul style="list-style-type: none"> • limited to 60 s switching at zero current maximum 	106 A; Use minimum cross-section acc. to AC-1 rated value
no-load switching frequency	
<ul style="list-style-type: none"> • at AC 	5 000 1/h
<ul style="list-style-type: none"> • at DC 	1 500 1/h
operating frequency	
<ul style="list-style-type: none"> • at AC-1 maximum 	1 000 1/h
<ul style="list-style-type: none"> • at AC-2 maximum 	750 1/h
<ul style="list-style-type: none"> • at AC-3 maximum 	750 1/h
<ul style="list-style-type: none"> • at AC-4 maximum 	250 1/h
Control circuit/ Control	
type of voltage of the control supply voltage	DC
control supply voltage at DC	
<ul style="list-style-type: none"> • rated value 	24 V
operating range factor control supply voltage rated value of magnet coil at DC	
<ul style="list-style-type: none"> • initial value 	0.8
<ul style="list-style-type: none"> • full-scale value 	1.1
closing power of magnet coil at DC	5.9 W
holding power of magnet coil at DC	5.9 W
closing delay	
<ul style="list-style-type: none"> • at DC 	50 ... 170 ms
opening delay	
<ul style="list-style-type: none"> • at DC 	15 ... 17.5 ms
arcing time	10 ... 10 ms
control version of the switch operating mechanism	Standard A1 - A2
Auxiliary circuit	
number of NC contacts for auxiliary contacts	
<ul style="list-style-type: none"> • instantaneous contact 	1

number of NO contacts for auxiliary contacts	
• instantaneous contact	1
operational current at AC-12 maximum	10 A
operational current at AC-15	
• at 230 V rated value	10 A
• at 400 V rated value	3 A
• at 500 V rated value	2 A
• at 690 V rated value	1 A
operational current at DC-12	
• at 24 V rated value	10 A
• at 48 V rated value	6 A
• at 60 V rated value	6 A
• at 110 V rated value	3 A
• at 125 V rated value	2 A
• at 220 V rated value	1 A
• at 600 V rated value	0.15 A
operational current at DC-13	
• at 24 V rated value	10 A
• at 48 V rated value	2 A
• at 60 V rated value	2 A
• at 110 V rated value	1 A
• at 125 V rated value	0.3 A
• at 220 V rated value	0.3 A
• at 600 V rated value	0.3 A
contact reliability of auxiliary contacts	1 faulty switching per 100 million (17 V, 1 mA)

UL/CSA ratings

full-load current (FLA) for 3-phase AC motor	
• at 480 V rated value	21 A
• at 600 V rated value	22 A
yielded mechanical performance [hp]	
• for single-phase AC motor	
— at 110/120 V rated value	2 hp
— at 230 V rated value	3 hp
• for 3-phase AC motor	
— at 200/208 V rated value	5 hp
— at 220/230 V rated value	7.5 hp
— at 460/480 V rated value	15 hp
— at 575/600 V rated value	20 hp
contact rating of auxiliary contacts according to UL	A600 / P600

Short-circuit protection

design of the fuse link	
--------------------------------	--

- for short-circuit protection of the main circuit
 - with type of coordination 1 required
 - with type of assignment 2 required
- for short-circuit protection of the auxiliary switch required

gG: 100 A (690 V, 100 kA), aM: 50 A (690 V, 100 kA), BS88: 100 A (415 V, 80 kA)

gG: 35A (690V, 100kA), aM: 20A (690V, 100kA), BS88: 35A (415V, 80kA)

gG: 10 A (500 V, 1 kA)

Installation/ mounting/ dimensions

mounting position	+/-180° rotation possible on vertical mounting surface; can be tilted forward and backward by +/- 22.5° on vertical mounting surface
fastening method	screw and snap-on mounting onto 35 mm standard mounting rail according to DIN EN 60715
<ul style="list-style-type: none"> • side-by-side mounting 	Yes
height	85 mm
width	45 mm
depth	107 mm
required spacing	
<ul style="list-style-type: none"> • with side-by-side mounting <ul style="list-style-type: none"> — forwards — upwards — downwards — at the side • for grounded parts <ul style="list-style-type: none"> — forwards — upwards — at the side — downwards • for live parts <ul style="list-style-type: none"> — forwards — upwards — downwards — at the side 	10 mm 10 mm 10 mm 0 mm 10 mm 10 mm 6 mm 10 mm 10 mm 10 mm 10 mm 6 mm

Connections/ Terminals

type of electrical connection	
<ul style="list-style-type: none"> • for main current circuit • for auxiliary and control circuit • at contactor for auxiliary contacts • of magnet coil 	screw-type terminals screw-type terminals Screw-type terminals Screw-type terminals
type of connectable conductor cross-sections	
<ul style="list-style-type: none"> • for main contacts <ul style="list-style-type: none"> — solid 	2x (1 ... 2.5 mm ²), 2x (2.5 ... 10 mm ²)

<ul style="list-style-type: none"> — solid or stranded — finely stranded with core end processing • at AWG cables for main contacts 	<p>2x (1 ... 2,5 mm²), 2x (2,5 ... 10 mm²)</p> <p>2x (1 ... 2.5 mm²), 2x (2.5 ... 6 mm²), 1x 10 mm²</p> <p>2x (16 ... 12), 2x (14 ... 8)</p>
connectable conductor cross-section for main contacts <ul style="list-style-type: none"> • solid • stranded • finely stranded with core end processing 	<p>1 ... 10 mm²</p> <p>1 ... 10 mm²</p> <p>1 ... 10 mm²</p>
connectable conductor cross-section for auxiliary contacts <ul style="list-style-type: none"> • solid or stranded • finely stranded with core end processing 	<p>0.5 ... 2.5 mm²</p> <p>0.5 ... 2.5 mm²</p>
type of connectable conductor cross-sections for auxiliary contacts <ul style="list-style-type: none"> — solid or stranded — finely stranded with core end processing 	<p>2x (0,5 ... 1,5 mm²), 2x (0,75 ... 2,5 mm²)</p> <p>2x (0.5 ... 1.5 mm²), 2x (0.75 ... 2.5 mm²)</p>
type of connectable conductor cross-sections at AWG cables for auxiliary contacts <ul style="list-style-type: none"> • type of connectable conductor cross-sections at AWG cables for auxiliary contacts 	<p>2x (20 ... 16), 2x (18 ... 14)</p>
AWG number as coded connectable conductor cross section <ul style="list-style-type: none"> • for main contacts • for auxiliary contacts 	<p>16 ... 8</p> <p>20 ... 14</p>

Safety related data	
B10 value <ul style="list-style-type: none"> • with high demand rate acc. to SN 31920 	1 000 000
proportion of dangerous failures <ul style="list-style-type: none"> • with low demand rate acc. to SN 31920 • with high demand rate acc. to SN 31920 	<p>40 %</p> <p>73 %</p>
failure rate [FIT] <ul style="list-style-type: none"> • with low demand rate acc. to SN 31920 	100 FIT
product function <ul style="list-style-type: none"> • mirror contact acc. to IEC 60947-4-1 	Yes
T1 value for proof test interval or service life acc. to IEC 61508	20 y
touch protection against electrical shock	finger-safe
suitability for use safety-related switching OFF	Yes

Certificates/ approvals

General Product Approval	EMC
--------------------------	-----



[KC](#)



Declaration of Conformity	Test Certificates	Marine / Shipping
---------------------------	-------------------	-------------------



[Miscellaneous](#)

[Type Test Certificates/Test Report](#)

[Special Test Certificate](#)

[Miscellaneous](#)



Marine / Shipping	other
-------------------	-------



[Confirmation](#)

other



Further information

Information- and Downloadcenter (Catalogs, Brochures,...)

<https://www.siemens.com/ic10>

Industry Mall (Online ordering system)

<https://mall.industry.siemens.com/mall/en/en/Catalog/product?mlfb=3RT2026-1BB40>

Cax online generator

<http://support.automation.siemens.com/WW/CAXorder/default.aspx?lang=en&mlfb=3RT2026-1BB40>

Service&Support (Manuals, Certificates, Characteristics, FAQs,...)

<https://support.industry.siemens.com/cs/ww/en/ps/3RT2026-1BB40>

Image database (product images, 2D dimension drawings, 3D models, device circuit diagrams, EPLAN macros, ...)

http://www.automation.siemens.com/bilddb/cax_de.aspx?mlfb=3RT2026-1BB40&lang=en

Characteristic: Tripping characteristics, I^t, Let-through current

<https://support.industry.siemens.com/cs/ww/en/ps/3RT2026-1BB40/char>

Further characteristics (e.g. electrical endurance, switching frequency)

<http://www.automation.siemens.com/bilddb/index.aspx?view=Search&mlfb=3RT2026-1BB40&objecttype=14&gridview=view1>

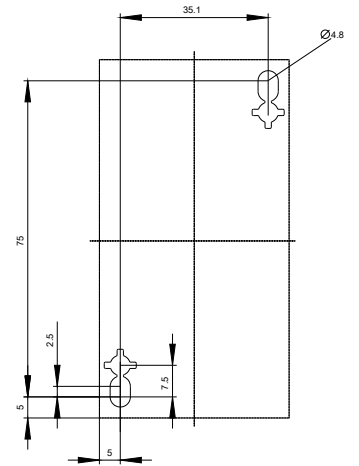
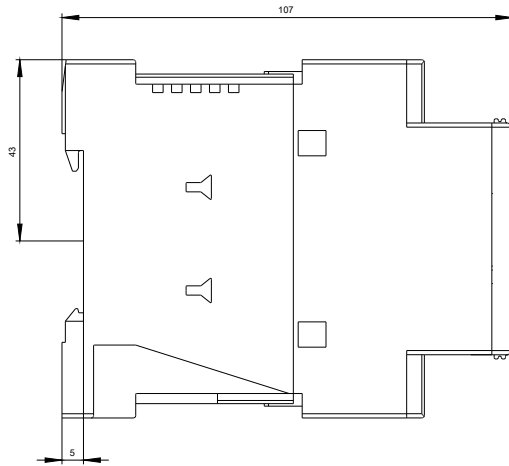
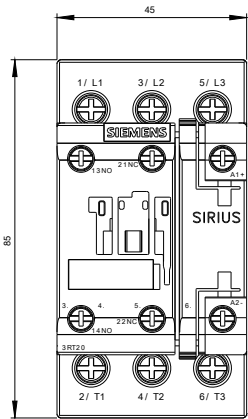

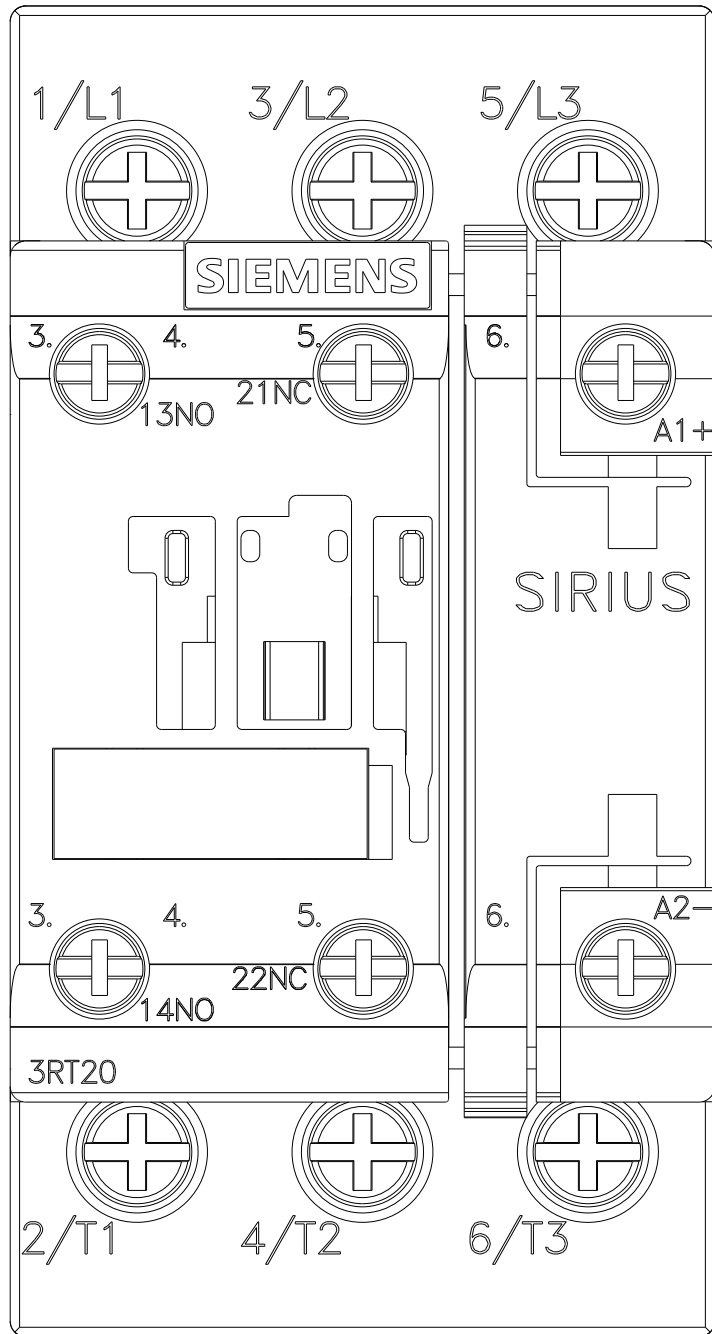

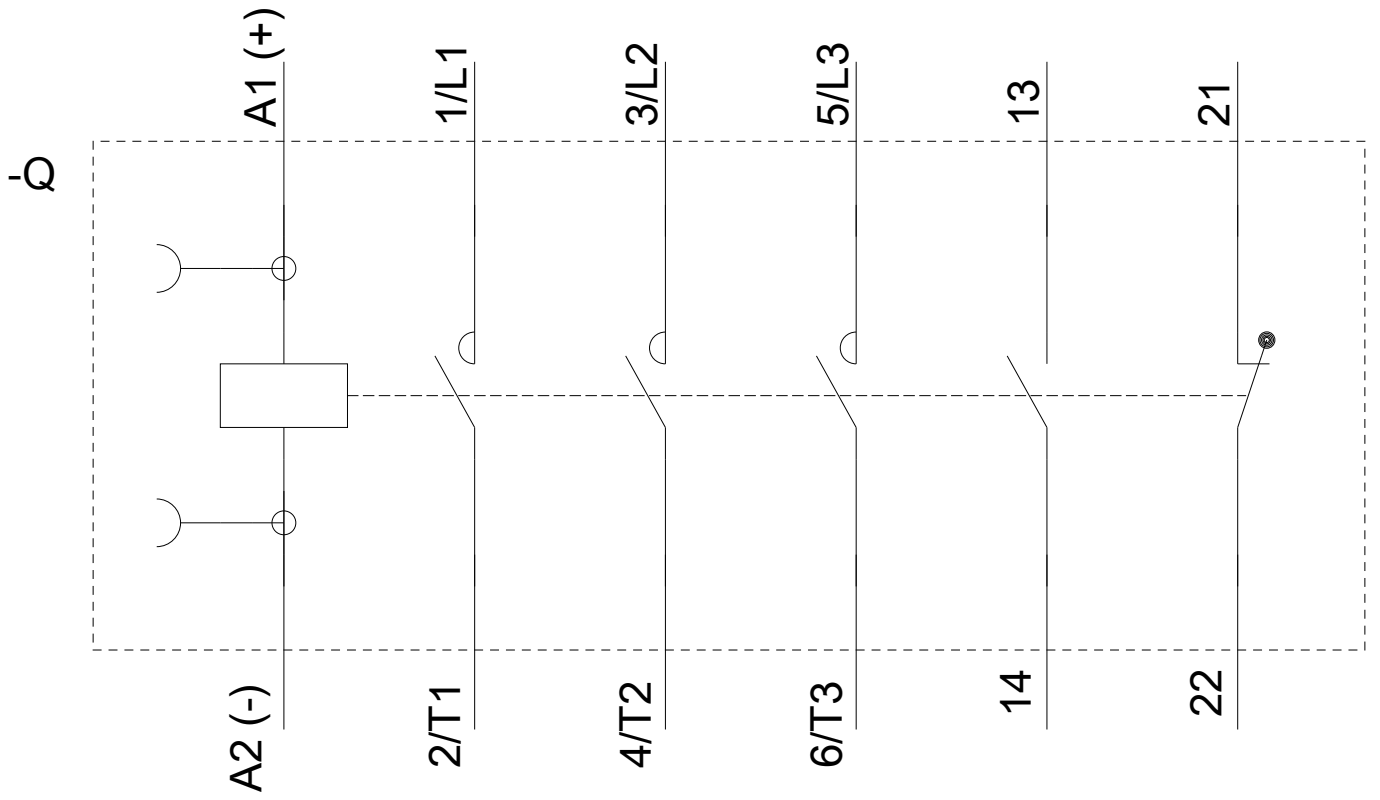

last modified:

11/23/2020