

Jul.1.2019 Copyright 2019 HIROSE ELECTRIC CO., LTD. All Rights Reserved.
 In case of consideration for using Automotive equipment / device which demand high reliability, kindly contact our sales window correspondents.

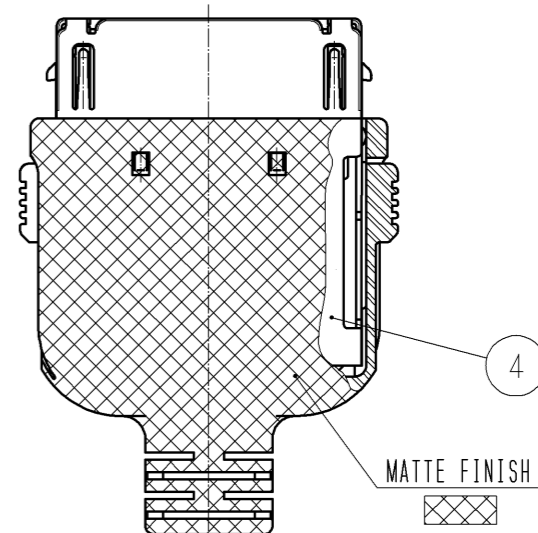
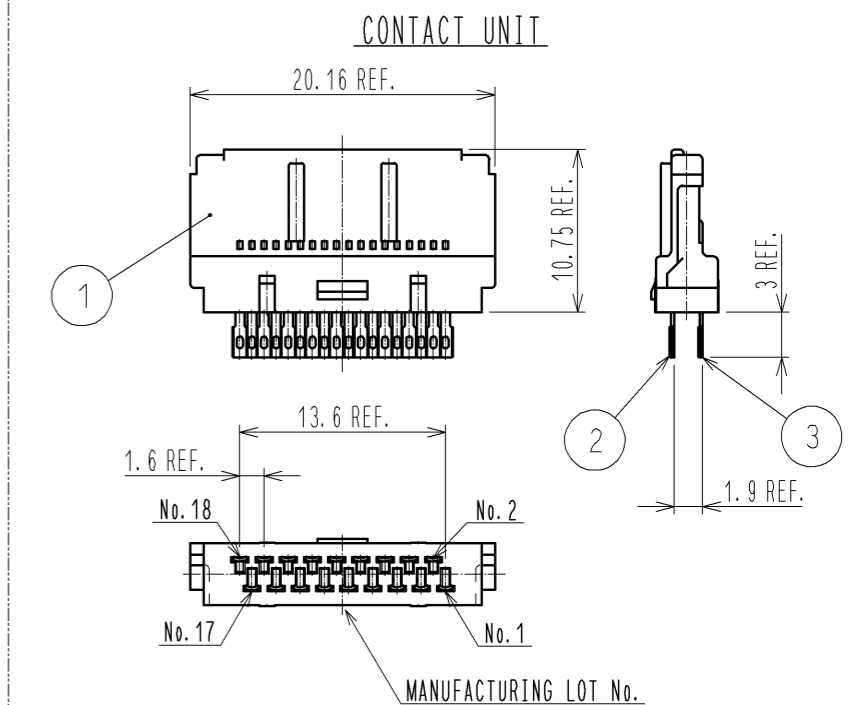
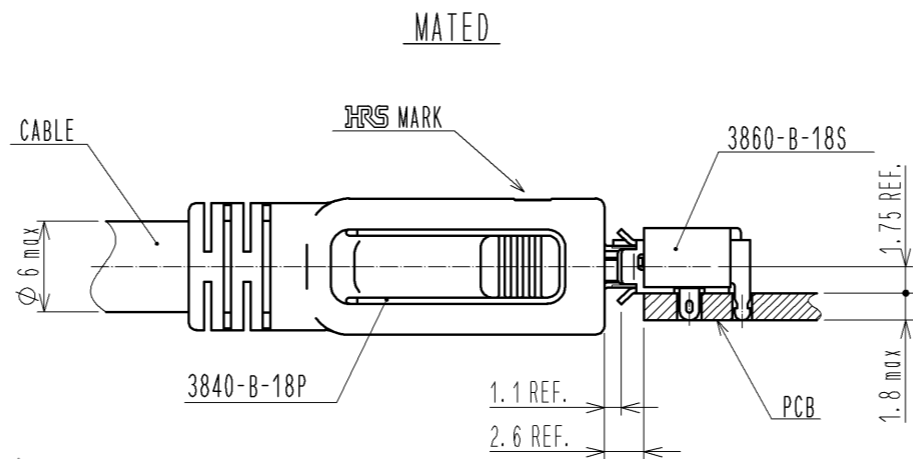
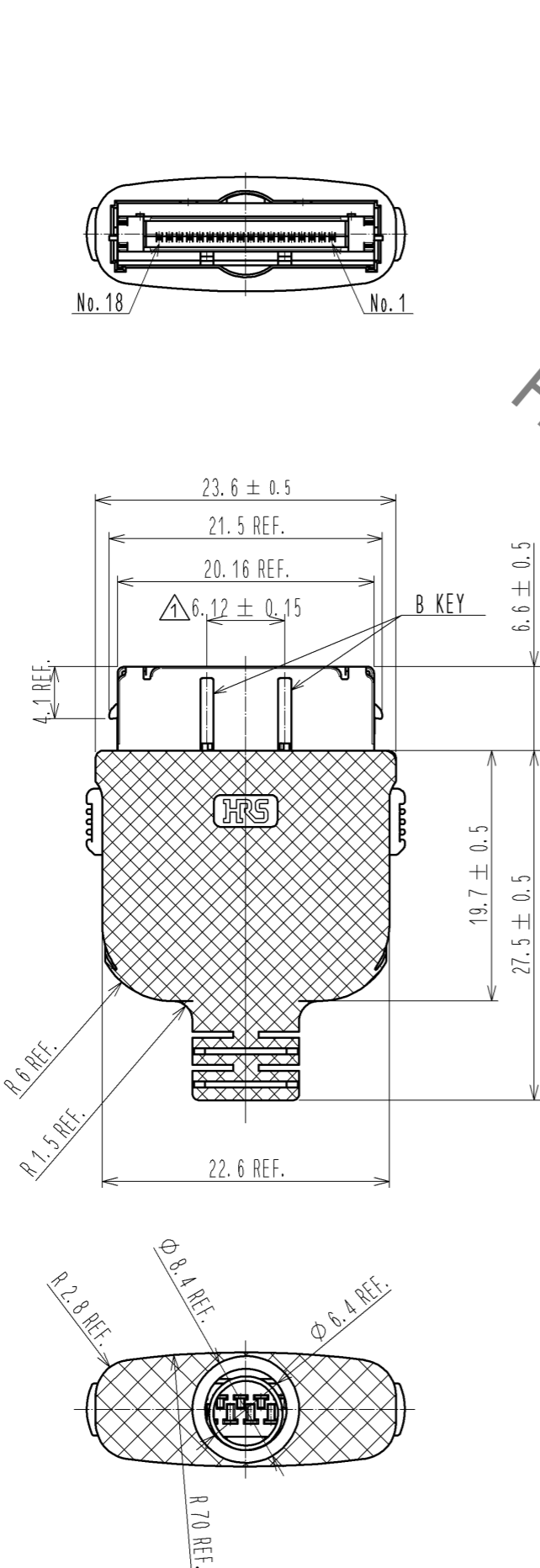

3	COPPER ALLOY	SELECTIVE GOLD PLATING 0.76 μm MIN	5	POLYCARBONATE	(BLACK) UL94V-0		
2	COPPER ALLOY	SELECTIVE GOLD PLATING 0.76 μm MIN	4	STAINLESS STEEL			
1	PA	(BLACK) UL94V-0					
NO.	MATERIAL	FINISH . REMARKS	NO.	MATERIAL	FINISH . REMARKS		
UNITS	mm	SCALE	COUNT	DESCRIPTION OF REVISIONS	DESIGNED	CHECKED	DATE
		2 : 1	1	DIS-E-003218	KO. KAWAMURA	TA. ASO	10.04.02
APPROVED : NF. MIYAZAKI		09.11.19	DRAWING NO.		EDC3-127059-00		
CHECKED : TA. ASO		09.11.18	PART NO.		3840-B-18P		
DESIGNED : KO. KAWAMURA		09.11.18	CODE NO.		CL238-2007-0-00		
DRAWN : KO. KAWAMURA		09.11.18					

[3840-**-18P PACKING SPECIFICATION]

<HOOD>

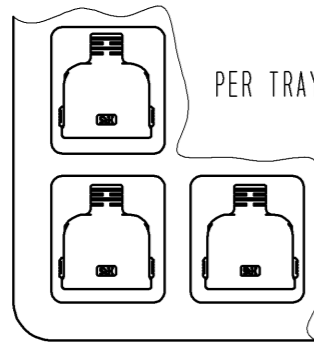
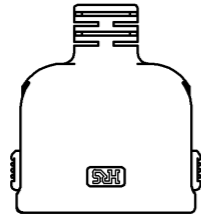

PER TRAY: 25 PCS MAX

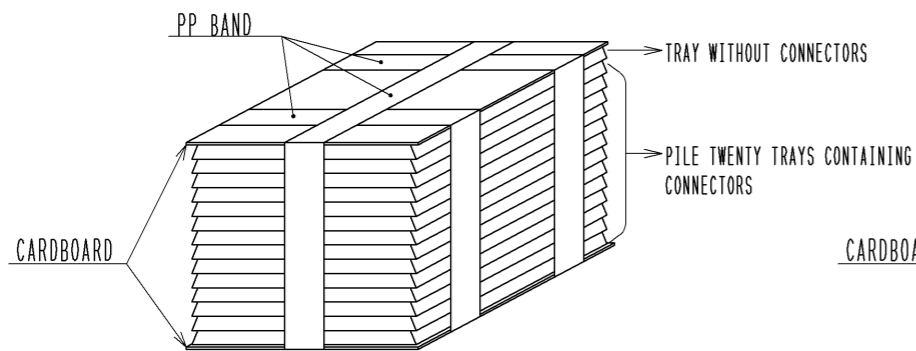

500 PCS MAX

<METAL SHELL>

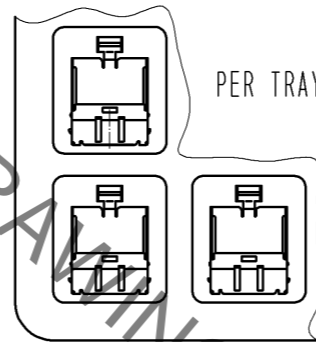
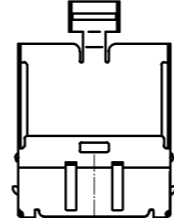

PER TRAY: 25 PCS MAX

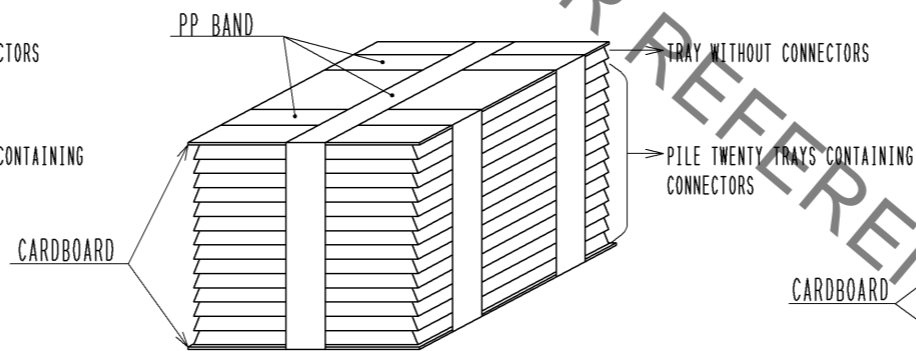

500 PCS MAX

<UNIT>

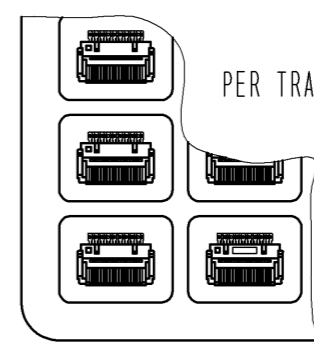
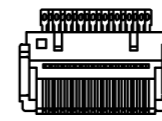

PER TRAY: 100 PCS MAX

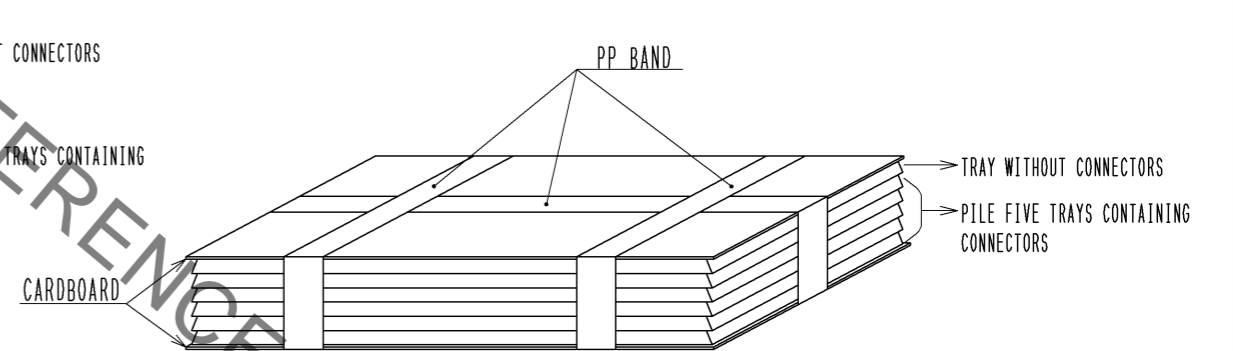

500 PCS MAX

PACKING SPECIFICATION

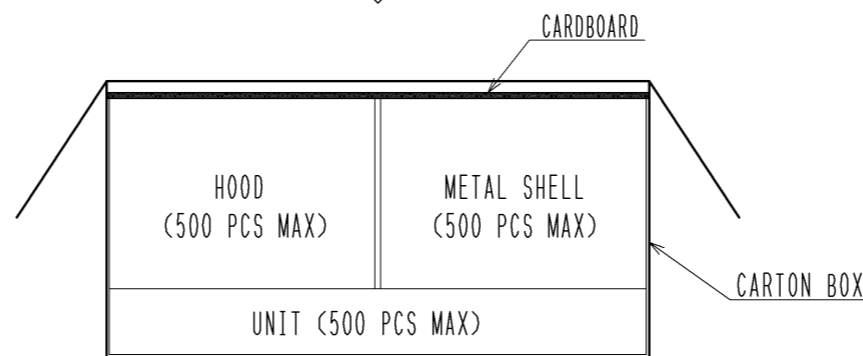
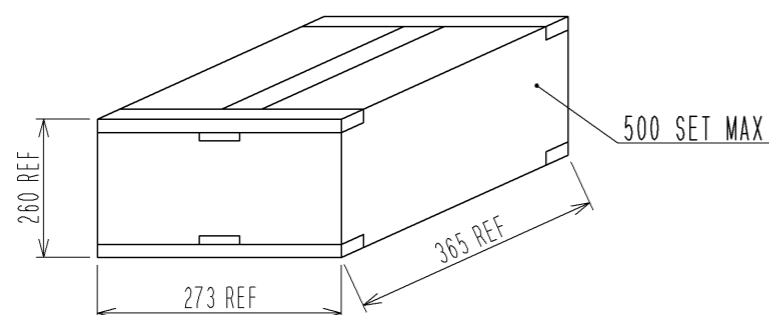

HRS DRAWING FOR REFERENCE

HRS	DRAWING NO.	EDC3-127059-00	2/2
	PART NO.	3840-B-18P	
	CODE NO.	CL238-2007-0-00	

In case of consideration for using Automotive equipment / device which demand high reliability, kindly contact our sales window correspondents.