

MATERIAL NO. STD OPT	MATERIAL NO. -50 OPT	NO. OF CIRCUITS	DIM. "A"		DIM. "B"		DIM. "C"	
			mm	in	mm	in	mm	in
382210002	382210302	02	53.1	2.09	14.3	.56	42.8	1.69
382210003	382210303	03	67.5	2.66	28.6	1.13	57.1	2.25
382210004	382210304	04	81.7	3.22	42.8	1.69	71.4	2.81
382210005	382210305	05	96.0	3.78	57.1	2.25	85.7	3.38
382210006	382210306	06	110.2	4.34	71.4	2.81	100.0	3.94
382210007	382210307	07	124.6	4.91	85.7	3.38	114.3	4.50
382210008	382210308	08	138.9	5.47	100.0	3.94	128.5	5.06
382210009	382210309	09	153.2	6.03	114.3	4.50	142.7	5.62
382210010	382210310	10	167.4	6.59	128.5	5.06	157.1	6.19
382210011	382210311	11	181.8	7.16	142.7	5.62	171.4	6.75
382210012	382210312	12	196.0	7.72	157.1	6.19	185.7	7.31
382210013	382210313	13	210.3	8.28	171.4	6.75	200.0	7.88
382210014	382210314	14	224.5	8.84	185.7	7.31	214.3	8.44
382210015	382210315	15	239.0	9.41	200.0	7.88	228.6	9.00

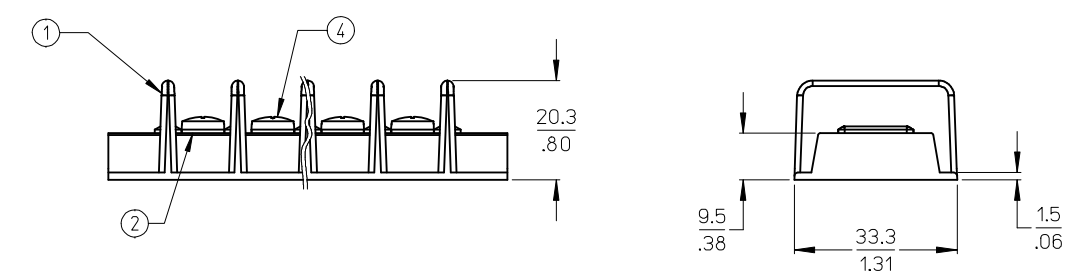
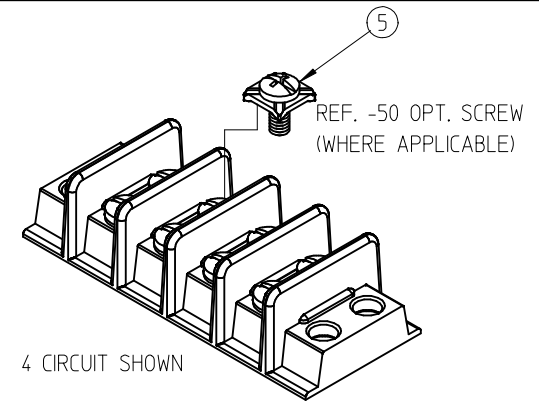
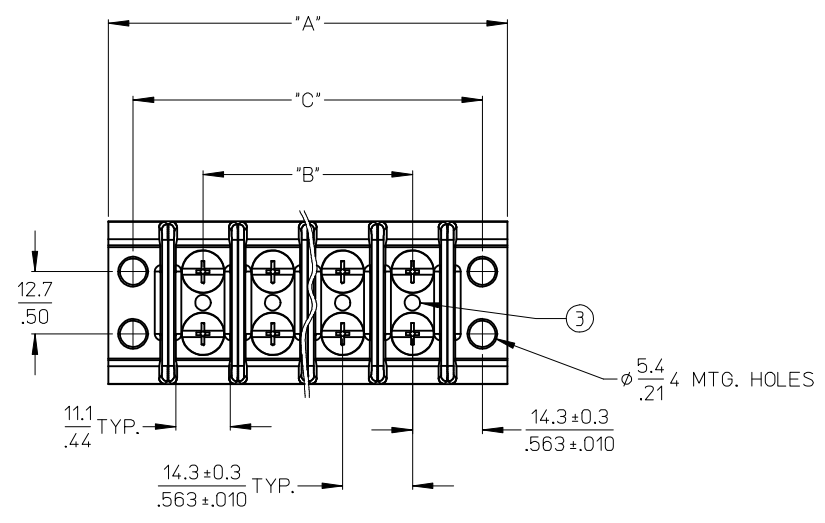

- NOTES:
1. MATERIAL: SEE TABLE
  2. FINISHES: SEE TABLE
  3. "XX" REFERS TO THE NUMBER OF CIRCUITS
  4. ROHS COMPLIANT

ITEM	QTY.	DESCRIPTION	MATERIAL	FINISH
5	"XX" *2	SCREW, #8-32, PAN HD., PHIL-SLOT, W/WASHER (-50 OPT)	STEEL	ZN, CLEAR CHROMATE
4	"XX" *2	SCREW, #8-32, BIND. HD., PHIL-SLOT, (STD)	STEEL	ZN, CLEAR CHROMATE
3	"XX"	SCREW, U-DRIVE, #0	STEEL	ZN, CLEAR CHROMATE
2	"XX"	EYELET TWIN TERMINAL	BRASS	NICKEL PLATE
1	1	MOLDING, CB BTS, 600V	PHENOLIC	BLACK

REDRAWN: ADD -50 OPT EC NO: IPG2013-1610 DRAWN: JENCINAS 2013/05/06 CHKD: JMACNEIL 2013/05/06 APPR: JMACNEIL 2013/06/06	QUALITY SYMBOLS ▽=0 ▽=0	GENERAL TOLERANCES (UNLESS SPECIFIED)		DIMENSION STYLE MM/IN		SCALE 1:1	DESIGN UNITS INCH	THIRD ANGLE PROJECTION			
		4 PLACES ± --- ± --- 3 PLACES ± --- ± .005 2 PLACES ± 0.13 ± .01 1 PLACE ± 0.3 ± ---	DRAWN BY JENCINAS	DATE 2013/05/06	TITLE .563" DOUBLE ROW BTS. .800" TALL RIBS, CLOSED BOTTOM		MOLEX INCORPORATED	DOCUMENT NO. SD-38221-001	SHEET NO. 1 OF 1	THIS DRAWING CONTAINS INFORMATION THAT IS PROPRIETARY TO MOLEX INCORPORATED AND SHOULD NOT BE USED WITHOUT WRITTEN PERMISSION	
		ANGULAR ± 2 °	DRAFT WHERE APPLICABLE MUST REMAIN WITHIN DIMENSIONS		SEE CHART						
		MATERIAL NO.		DRAWN BY JMACNEIL		DATE 2013/05/06		TITLE .563" DOUBLE ROW BTS. .800" TALL RIBS, CLOSED BOTTOM		THIS DRAWING CONTAINS INFORMATION THAT IS PROPRIETARY TO MOLEX INCORPORATED AND SHOULD NOT BE USED WITHOUT WRITTEN PERMISSION	