



Part Number : [1300662019](#)

Product Description : BradPower C-Size (1 1/8"-M29) Receptacle, 4 Poles, Tri-Key, 1/2" - 14 NPT, Female (Straight) to 12 AWG Leads, 2.0m (6.56') Length

Series Number : 130066

Status : Active

Product Category : Circular Industrial Connectors

Engineering Number : 3R4100A84M0203

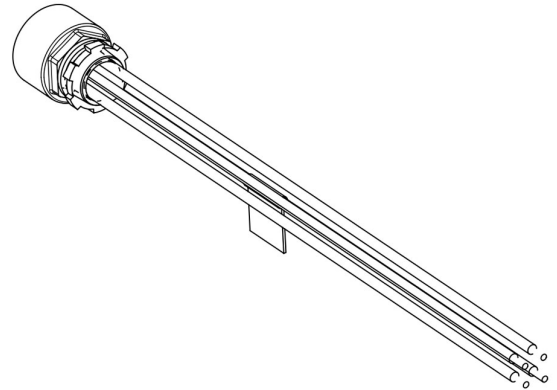

Documents & Resources

Drawings

[1300662019_sd.pdf](#)

Product Environment Compliance

Compliance

GADSL/IMDS	Not Relevant
China RoHS	Not Relevant
EU ELV	Not Reviewed per 2000/53/EC
Low-Halogen Status	Not Relevant
REACH SVHC	Contains Lead; diphenyl(2,4,6-trimethylbenzoyl)phosphine oxide per D(2024)4144-DC (27 June 2024)
EU RoHS	Compliant with Exemption 6(c) per EU 2015/863

Multiple Part Product Compliance Statements

- Eu RoHS
- REACH SVHC
- Low-Halogen

Multiple Part Industry Compliance Documents

- IPC 1752A Class C
- IPC 1752A Class D
- Molex Product Compliance Declaration

- IEC-62474

- chemSHERPA (xml)

EU RoHS Certificate of Compliance

Part Details

General

Status	Active
Category	Circular Industrial Connectors
Series	130066
Description	BradPower C-Size (1 1/8"-M29) Receptacle, 4 Poles, Tri-Key, 1/2" - 14 NPT, Female (Straight) to 12 AWG Leads, 2.0m (6.56') Length
IP Rating	IP67
Product Name	BradPower C-Size
Type	Single Ended (pigtail)
UPC	78172557816

Agency

UL	E258922
----	---------

Electrical

Current - Maximum per Contact	25.0A
Voltage - Maximum	600V

Physical

Coupling Type	Internal Thread
Gender	Female
Keyway	Tri-Key
Length	2.0m
Material - Component	Nickel-plated Brass
Mounting Thread Size	1/2" - 14 NPT
Net Weight	244.000/g
Orientation	Straight
Panel Mount	Front
Poles	4

Temperature Range - Operating	-20° to +90°C
Wire/Cable Type	UL 1015
Wire Size (AWG)	12

This document was generated on Feb 13, 2025