

DWG. NO.  
SD-35141-030

SIMILAR ITEM

PROJECT NO.

DO NOT SCALE DRAWING  
DIMENSION IN METRIC

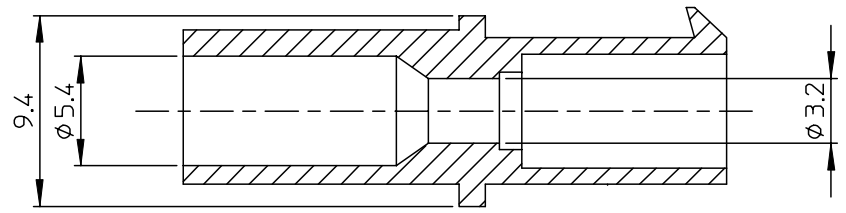
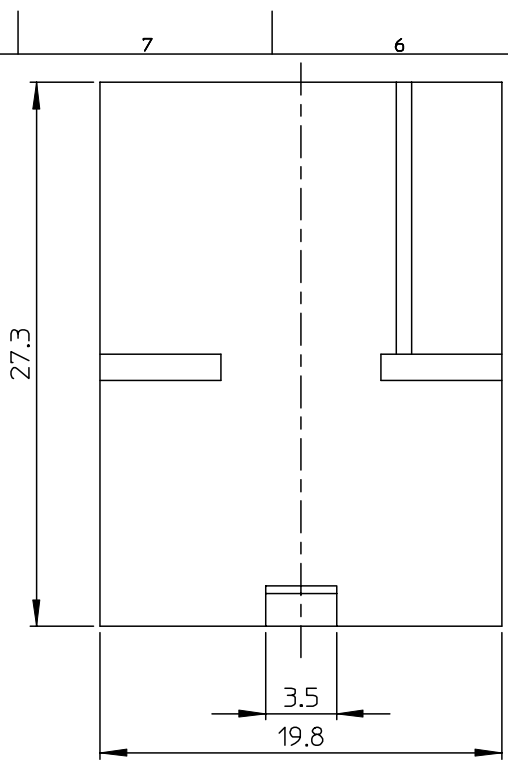

SECTION A-A

- NOTES
1. MATERIAL : NYLON66,UL94V-2  
NATURAL COLOR
  2. APPLICABLE TERMINAL : 35727-0201
  3. MATED PLUG HOUSING : 35143-0301

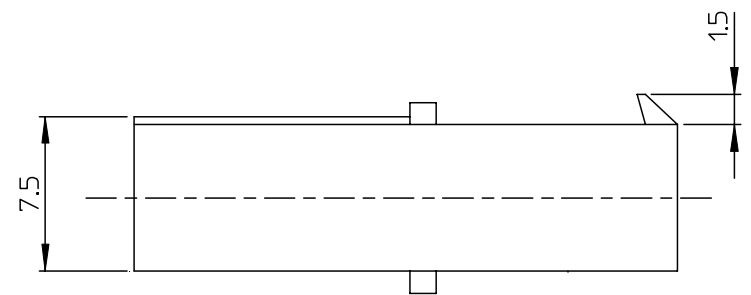
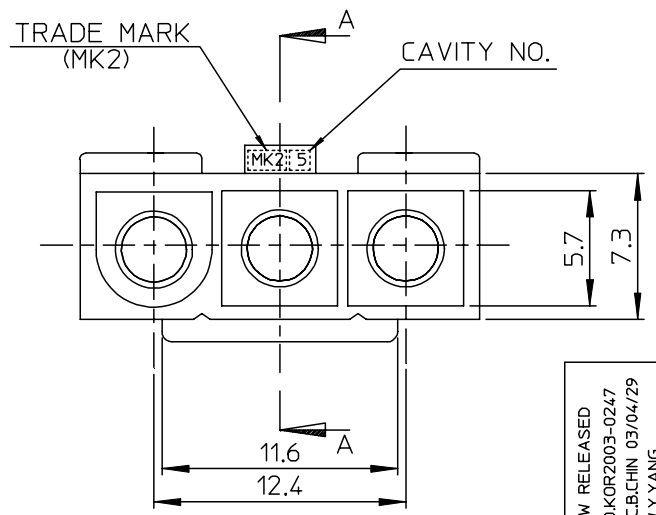

|  |  |   |         |   |  |   |   |                       |
|--|--|---|---------|---|--|---|---|-----------------------|
| NEW RELEASED<br>ECN NO. KR2003-0247<br>DRWN: C.B.CHIN 03/04/29<br>CHK: W.Y.YANG<br>APPR: C.W.LEE | QUALITY SYMBOLS<br>MAJOR $\nabla = 0$<br>CRITICAL $\nabla C = 0$ | GENERAL TOLERANCES:<br>(UNLESS SPECIFIED) |         | SCALE<br>4:1  | DESIGN UNITS<br><input checked="" type="checkbox"/> mm <input type="checkbox"/> INCH | THIRD ANGLE PROJECTION<br><input checked="" type="checkbox"/> mm <input type="checkbox"/> INCH ONLY | SHT<br>REV  |                       |
|  |  | 4 PLACES $\pm 0.$                         | $\pm -$ | mm  | INCH   | DRAWN BY & DATE<br>C.B.CHIN 03/03/17  | TITLE:<br>2.0 DIA REC' HOUSING-3P<br>(WITHOUT MOUNTAER) | REVISE ON<br>CAD ONLY |
| A  | REV  | 3 PLACES $\pm 0.$                         | $\pm -$ | CHECKED BY & DATE<br>W.Y.YANG 03/03/17  |  | MOLEX INCORPORATED  | SHEET NO.<br>1 OF 1                                     |                       |
|  |  | 2 PLACES $\pm 0.$                         | $\pm -$ | APPROVED BY & DATE<br>C.W.LEE 03/03/17  |  |   |   |                       |
|  |  | 1 PLACE $\pm 0.3$                         | $\pm -$ | ANGULAR: $\pm 1^\circ$  | CAD FILENAME<br>S1410300AA.MI  | MATERIAL NO.<br>351410300   | DRAWING NO.<br>SD-35141-030                             | SIZE<br>B             |
| DRAFT WHERE APPLICABLE MUST<br>REMAIN WITHIN DIMENSIONS  |  |   |         | THIS DRAWING CONTAINS INFORMATION THAT IS PROPRIETARY TO MOLEX<br>INCORPORATED AND SHOULD NOT BE USED WITHOUT WRITTEN PERMISSION. |  |   |   | KOREA<br>MX-A3        |