

Data sheet
RT083xxDBWC Typ 105

Illustrations

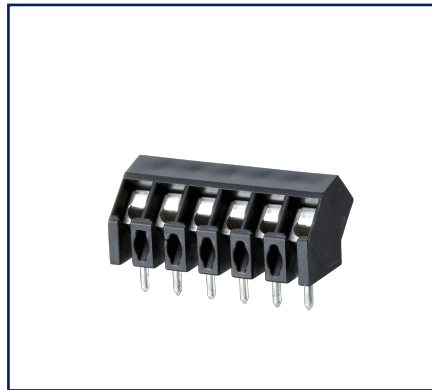

Dimensional drawing

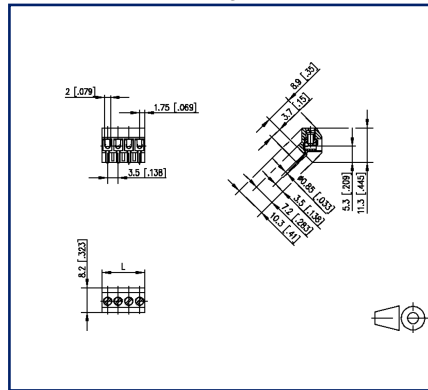

Drill pattern

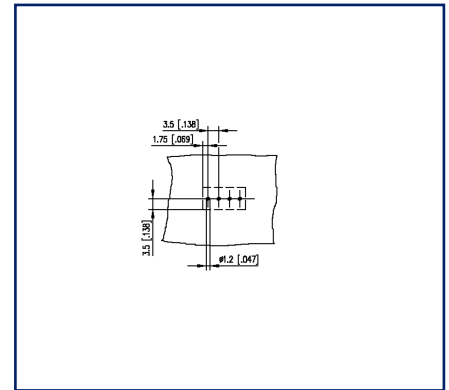



See enlarged drawings at the end of document

Product specification

- screw type terminal block, solderable
- centerline 3.50 mm, direction of connection 45°
- wire protector, fittable without loss of poles
- color black

Technical Data

General Data			
Tightening torque SEV	0.15 Nm		
Tightening torque UL	1.3 lb-in		
Solder pin length	3.7 mm		
min. number of poles	2		
max. number of poles	16		
Insulating material class	CTI 600		
clearance/creepage dist.	2.1 mm		
Protection category	IP20		
Min. insul. strip length	5 mm		
Rated current	6 A		
Overvoltage category	III	III	II
Pollution degree	3	2	2
Rated voltage	40 V	250 V	250 V
Rated test voltage	1.5 kV	1.5 kV	1.5 kV
Anschlussdaten			
rat.wiring solid AWGmax	0.34 mm ² - 1 mm ² / AWG 22 - AWG 18		
rat.wiring strand.AWGmax	0.34 mm ² - 1 mm ² / AWG 22 - AWG 18		
Approvals			
 V / A / AWG	300 / 10 / 28 - 16		
approval UL - File No.	E121004		
 1 mm ²	130 V / 13.5 A / T60		
Material			
insulating material	PA66		
flammability class	V0		
terminal body thread	M2		
terminal body material	CuZnPb		
terminal body surface	Ni + Sn		
screw thread	M2		
screw material	8,8		
screw surface	Zn Cr(VI)-frei/free		
wire protector material	CuSn		
wire protector surface	Sn		
Glow-Wire Flammability GWFI	960 °C acc. to IEC 60695-2-12		

U | Contact

Data sheet RT083xxDBWC Typ 105

Page 3/5

P/N
311051xx

xx=number of poles

2021/09/15

Version: AA

Technical Data

Glow-Wire Flammability GWIT	775 °C acc. to IEC 60695-2-13
REACH - substance (SVHC)	Lead / 7439-92-1

Climatic Data

upper limit temperature	105 °C
lower limit temperature	-40 °C

general

Tolerance	ISO 2768 -mH
Solderability	Acc. to JEDEC JESD22-B102E 245°C/5s



Illustrations

Dimensional drawing

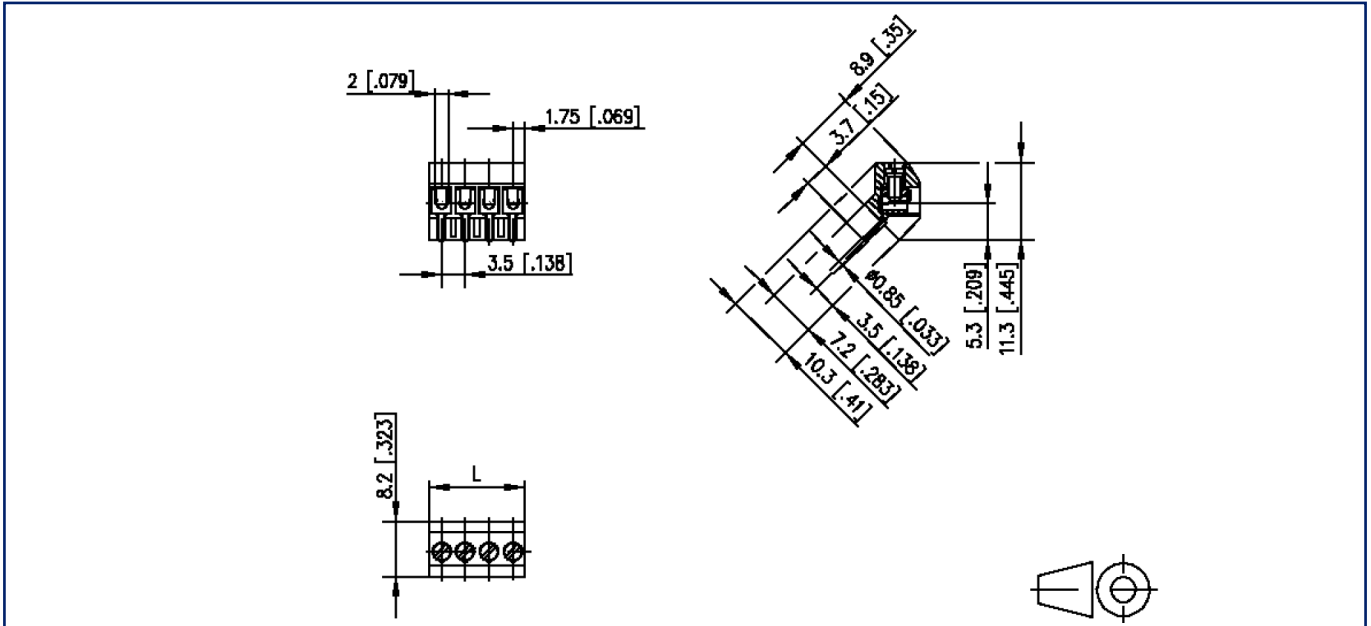

$L = (\text{pole size} - 1) \times \text{centerline} + 3.5 \text{ mm } [0.138]$

© 2021 METZ CONNECT - Technische Änderungen vorbehalten! Subject to modifications! Sous réserve de modifications techniques!

Illustrations

Drill pattern

