

8

7

6

5

4

3

2

1

VICOR CONFIDENTIAL

THIS DOCUMENT AND THE DATA DISCLOSED HEREIN OR HEREWITH IS NOT TO BE REPRODUCED, USED OR DISCLOSED IN WHOLE OR IN PART TO ANYONE WITHOUT THE PERMISSION OF VICOR CORP.

REVISIONS

REV	DESCRIPTION	DATE	APPROVED
1	RELEASED PER E064258	01/25/06	MH
2	REVISED PER E101188	09/24/10	AR

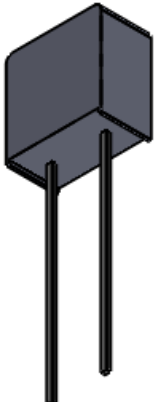
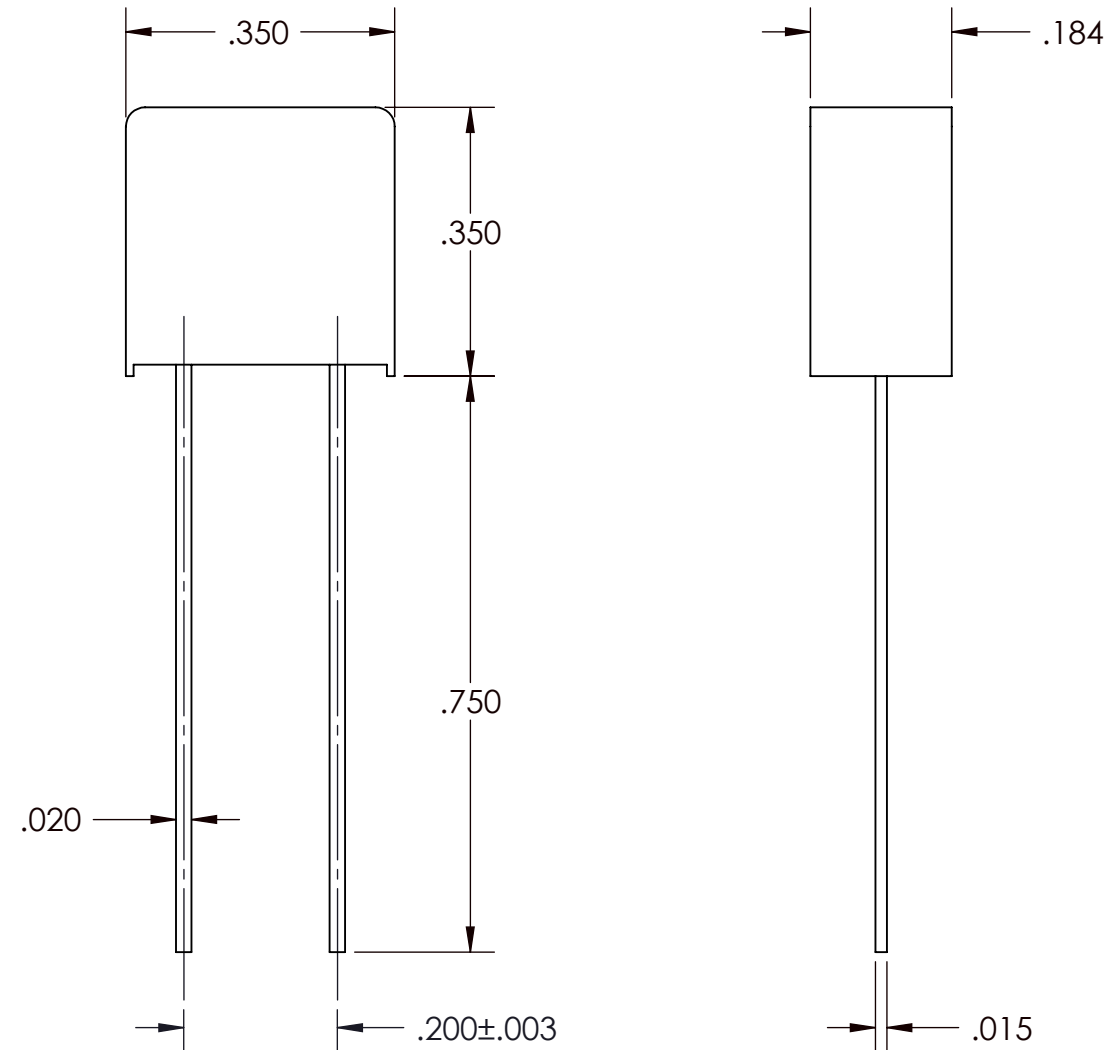

NOTES:

- 1. RoHS COMPLIANT, LEAD FREE PER CST-0001 LATEST REVISION.
- 2. UL RECOGNIZED FILE E19180, GUIDE JDYX2; CSA CERTIFIED FILE 42731, CLASS 1421-01

ELECTRICAL SPECIFICATIONS

AMPERAGE	3 AMPS
VOLTAGE	250 VOLTS
INTERRUPTING & VOLTAGE RATINGS	50 AMPS
TIME- CURRENT CHARACTERISTICS	CARRY 100% FOR 4 HRS MIN. OPEN AT 200% IN 10 SEC MAX.
COLD RESISTANCE DATA	0.071 W

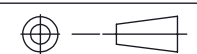
DRAWN	DATE				
P.E.IENI	08/02/05				
MATERIAL	UNLESS OTHERWISE SPECIFIED DIMENSIONS ARE INCH [MM] TOLERANCES ARE: DECIMALS ANGLES X.XX [X.X] = ±0.01 [0.25] ±1° X.XXX [X.XX] = ±0.005 [0.127]	<p align="center">FUSE 3A 250V LEADED</p>			
FINISH	THIRD ANGLE PROJECTION  DO NOT SCALE DRAWING				SIZE
		B	67131	30243	2
		SCALE 4: 1	SHEET 1 OF 1		

8

7

6

5

4

3

2

1