

Long Nose Pliers

- > Heavy duty and wear resisting
- > Different jaw styles
- > Chrome vanadium electric steel, forged, oil-hardened
- > DIN ISO 5745

Style 1

- > Long, trapezoidal jaws; knurled gripping surfaces

Style 2

- > Long, half-round jaws; knurled gripping surfaces

Style 3

- > Long, round jaws; smooth gripping surfaces

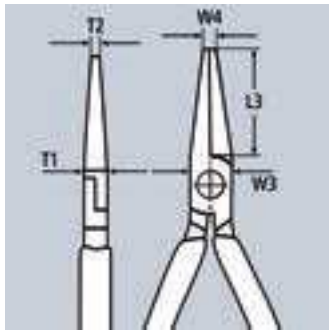

30 11 160



30 15 160



30 16 160



30 25 160

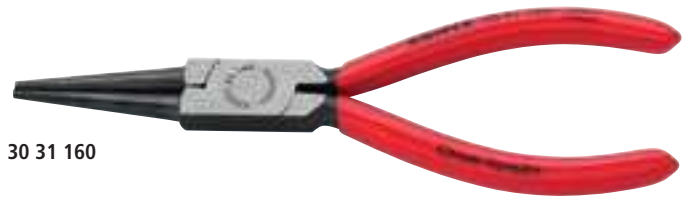

30 31 160

Article No.	EAN 4003773-	↔ mm		Style	Pliers	Head	Handles	Dimensions					 g
								L3 mm	W3 mm	T1 mm	W4 mm	T2 mm	
30 11 140	033936	140		1				42.0	15.0	8.0	2.5	4.0	86
30 11 160	023128	160		1	black anodized	polished	plastic coated	46.5	16.5	9.5	3.0	5.0	121
30 11 190	043492	190		1				50.0	18.5	9.5	3.0	7.0	145
30 13 140	016298	140		1	chrome plated	chrome plated	plastic coated	42.0	15.0	8.0	2.5	4.0	87
30 13 160	043485	160		1				46.5	16.5	9.5	3.0	5.0	118
30 15 140	042914	140		1				42.0	15.0	8.0	2.5	4.0	106
30 15 160	035046	160		1	chrome plated	chrome plated	with multi-component grips	46.5	16.5	9.5	3.0	5.0	149
30 15 190	001881	190		1				50.0	18.5	8.0	3.0	7.0	171
30 16 160	001904	160		1	chrome plated	chrome plated	insulated with multi-component grips, VDE-tested	46.5	16.5	9.5	3.0	5.0	150
30 21 140	042433	140		2				42.0	15.0	8.0	2.5	2.0	95
30 21 160	035053	160		2	black anodized	polished	plastic coated	50.0	16.5	9.5	3.0	2.5	121
30 21 190	043508	190		2				50.0	18.5	8.0	3.0	2.4	145
30 23 140	016373	140		2	chrome plated	chrome plated	plastic coated	42.0	15.0	8.0	2.5	2.0	95
30 25 140	001980	140		2				42.0	15.0	8.0	2.5	2.0	114
30 25 160	035060	160		2	chrome plated	chrome plated	with multi-component grips	50.0	16.5	9.5	3.0	2.5	151
30 25 190	043515	190		2				50.0	18.5	8.0	3.0	2.4	168
30 31 160	035077	160		3	black anodized	polished	plastic coated	41.0	16.5	9.5	5.0	2.5	110
30 33 160	043539	160		3	chrome plated	chrome plated	plastic coated	41.0	16.5	9.5	5.0	2.5	111
30 35 140	043102	140		3				37.5	15.0	8.0	4.0	2.0	102
30 35 160	035084	160		3	chrome plated	chrome plated	with multi-component grips	41.0	16.5	9.5	5.0	2.5	138
30 36 160	002123	160		3	chrome plated	chrome plated	insulated with multi-component grips, VDE-tested	41.0	16.5	9.5	5.0	2.5	141