



ALL RIGHTS RESERVED. NO PORTION OF THIS PUBLICATION, WHETHER IN WHOLE OR IN PART CAN BE REPRODUCED WITHOUT THE EXPRESS WRITTEN CONSENT OF SPC TECHNOLOGY.

SPC-F005.DWG

REVISIONS

DOC. NO. SPC-F005 * Effective: 7/8/02 * DCP No: 1398

DCP #	REV	DESCRIPTION	DRAWN	DATE	CHECKD	DATE	APPRVD	DATE
1447	A	RELEASED	HO	6/25/03	JWM	6/25/03	DJC	6/25/03
1885	B	UPDATED TO ROHS COMPLIANCE	EO	02/03/06	HO	2/6/06	HO	2/6/06



Description: SILICON TO-126 PNP POWER TRANSISTOR For use in power amplifier and switching excellent safe area limits.

Absolute Maximum Ratings:

- Collector-Base Voltage, $V_{CBO} = 40V$
- Collector-Emitter Voltage, $V_{CEO} = 40V$
- Emitter-Base Voltage, $V_{EBO} = 5V$
- Continuous Collector Current, $I_C = 4A$
- Base Current, $I_B = 1A$
- Total Device Dissipation ($T_C = +25^\circ C$), $P_D = 40W$
Derate above $25^\circ C = 320mW/^\circ C$
- Operating Junction Temperature Range, $T_J = -65^\circ$ to $+150^\circ C$
- Storage Temperature Range, $T_{stg} = -65^\circ$ to $+150^\circ C$

Electrical Characteristics: ($T_A = +25^\circ C$ unless otherwise specified)

Parameter	Symbol	Test Conditions	Min	Max	Unit
OFF Characteristics					
Collector-Emitter Breakdown Voltage (Note 1)	$V_{(BR)CEO}$	$I_C = 0.1A, I_B = 0$	40	-	V
Collector Cut-Off Current	I_{CEX}	$V_{CE} = 40V, V_{EB(off)} = 1.5V$	-	0.1	mA
	I_{CBO}	$V_{CB} = 40V, I_B = 0$	-	0.1	mA
	I_{CEO}	$V_{CB} = 40V, I_B = 0$	-	1	mA
Emitter Cut-Off Current	I_{EBO}	$V_{EB} = 5V, I_C = 0$	-	1	mA
ON Characteristics					
DC Current Gain (Note 1)	h_{FE}	$V_{CE} = 2V, I_C = 1.5A$	25	100	-
		$V_{CE} = 2V, I_C = 4A$	10	-	-
Collector-Emitter Saturation Voltage (Note 1)	$V_{CE(sat)}$	$I_C = 1.5A, I_B = 0.15A$	-	0.6	V
		$I_C = 4A, I_B = 1A$	-	1.4	V
Base-Emitter On Voltage (Note 1)	$V_{BE(on)}$	$I_C = 1.5A, I_B = 2V$	-	1.2	V
Small-Signal Characteristics					
Current Gain-Bandwidth Product (Note 2)	f_T	$V_{CE} = 10V, I_C = 1A, f = 1MHz$	2	-	MHz

Note 1. Pulse Test: Pulse Width $\leq 300\mu s$, Duty Cycle $\leq 2\%$.

Note 2. f_T is defined as the frequency at which $|h_{fe}|$ extrapolates to unity.

STYLE 1
PIN 1. EMITTER
2. COLLECTOR
3. BASE

Dim	Min	Max
A	10.8	11.05
B	7.49	7.75
C	2.41	2.67
D	0.51	0.66
F	2.92	3.18
G	2.31	2.46
H	1.27	2.41
J	0.38	0.64
K	15.11	16.64
M	3' TYP	
Q	3.76	4.01
R	1.14	1.40
S	0.64	0.89
U	3.68	3.94
V	1.02	-

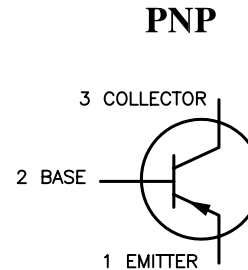
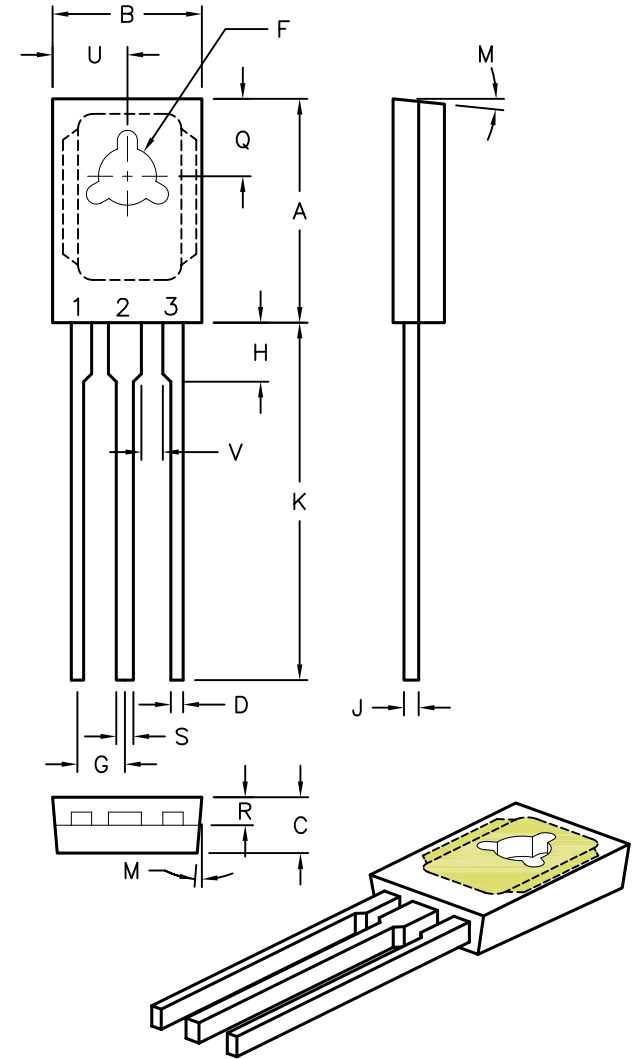

DISCLAIMER: ALL STATEMENTS AND TECHNICAL INFORMATION CONTAINED HEREIN ARE BASED UPON INFORMATION AND/OR TESTS WE BELIEVE TO BE ACCURATE AND RELIABLE. SINCE CONDITIONS OF USE ARE BEYOND OUR CONTROL, THE USER SHALL DETERMINE THE SUITABILITY OF THE PRODUCT FOR THE INTENDED USE AND ASSUME ALL RISK AND LIABILITY WHATSOEVER IN CONNECTION THEREWITH.

TOLERANCES:
UNLESS OTHERWISE SPECIFIED, DIMENSIONS ARE FOR REFERENCE PURPOSES ONLY.

DRAWN BY:	DATE:
HISHAM ODISH	6/25/03
CHECKED BY:	DATE:
JEFF MCVICKER	6/25/03
APPROVED BY:	DATE:
DANIEL CAREY	6/25/03

DRAWING TITLE: Transistor, Bipolar, Plastic, Silicon, TO-126, PNP			
SIZE	DWG. NO.	ELECTRONIC FILE	REV
A	2N5193	01H1378.DWG	B
SCALE: NTS	U.O.M.: MILLIMETERS	SHEET: 1 OF 1	