

ENERGIZER 2L76



Industry Standard Dimensions

mm (inches)



This Battery has Underwriters Laboratories component Recognition

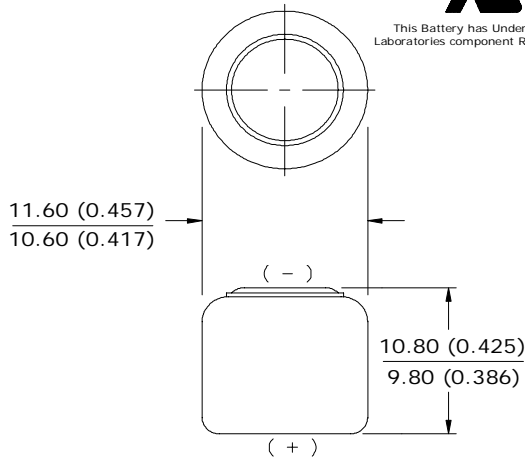

Specifications

- Classification:** "Lithium Photo"
- Chemical System:** Lithium / Manganese Dioxide (Li/MnO₂)
- Designation:** IEC-CR11108
- Nominal Voltage:** 3.0 Volts
- Storage Temp:** -40°C to 60°C (-40°F to 140°F)
- Operating Temp:** -40°C to 60°C (-40°F to 140°F)
- Typical Capacity:** 160 mAh (to 2.0 volts)
(Rated at 15k ohms at 21°C)
- Typical Weight:** 3.0 grams (0.1 oz.)
- Typical Volume:** 1.1 cubic centimeters (0.074 cubic inch)
- Max Discharge:** 60 mA continuous (80 mA pulse)
- Max Rev Charge:** 1 microampere
- Typical Li Content:** 0.056 grams (0.002 oz.)
- UL Listed:** MH12454
- Shipping:** For complete details, please reference:
Global (except US): Special Provision A45 of the International Air Transport Association Dangerous Goods Regulations
United States: 49 CFR 173.185

Typical Discharge Characteristics

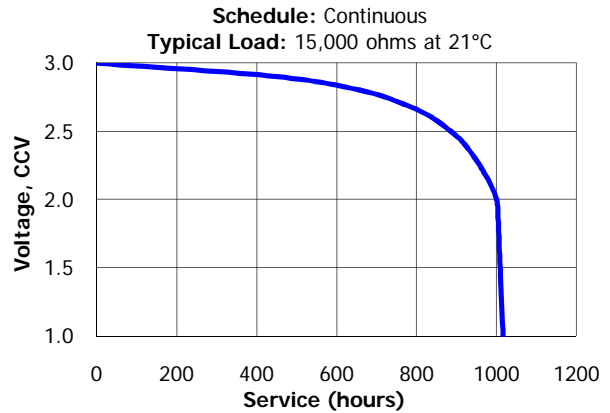

Simulated Application Tests

Typical Performance at 21°C (70°F)

Schedule (time)	Drain (mA)	Load (ohms)	Cutoff Voltage		
			2.6V (hours)	2.4V (hours)	2.0V (hours)
Continuous	0.16	15000	840	920	1000

Important Notice

This datasheet contains typical information specific to products manufactured at the time of its publication.
©Energizer Holdings, Inc. - Contents herein do not constitute a warranty.