

## Power/input isolating amplifier - MACX MCR-EX-SL-RPSSI-I-SP - 2924016

Please be informed that the data shown in this PDF Document is generated from our Online Catalog. Please find the complete data in the user's documentation. Our General Terms of Use for Downloads are valid (<http://phoenixcontact.com/download>)



Ex i repeater power supply and input signal conditioner, HART. Transmits supplied or active 0/4 - 20 mA signals from the hazardous area to a load (active or passive) in the safe area. 3-way electrical isolation; SIL 2 according to IEC 61508, with push-in connection

The illustration shows the versions with screw connection

### Product Features

- 0/4 mA ... 20 mA input, intrinsically safe, [Ex ia], powered and not powered
- Measuring transducer supply voltage > 16 V
- 0/4 mA ... 20 mA output, active up to 1000 # load or passive
- Bidirectional HART signal transmission
- Error indication according to NAMUR NE 43
- SIL 2 according to IEC 61508/EN 61508
- Installation in Ex zone 2 permitted
- 3-way electrical isolation
- Power supply possible via DIN rail connector
- Plug-in connection terminals, push-in connection technology
- Design width of just 12.5 mm
- Minimal power dissipation
- High transmission accuracy



### Key Commercial Data

Packing unit	1 pc
Weight per Piece (excluding packing)	160.0 g
Custom tariff number	85437090
Country of origin	Germany

# Power/input isolating amplifier - MACX MCR-EX-SL-RPSSI-I-SP - 2924016

## Technical data

### Note

Utilization restriction	EMC: class A product, see manufacturer's declaration in the download area
-------------------------	---

### Dimensions

Width	12.5 mm
Height	116 mm
Depth	114.5 mm

### Ambient conditions

Ambient temperature (operation)	-20 °C ... 60 °C (Any mounting position)
Ambient temperature (storage/transport)	-40 °C ... 80 °C
Maximum altitude	≤ 2000 m
Permissible humidity (operation)	10 % ... 95 % (non-condensing)
Noise immunity	EN 61000-6-2 When being exposed to interference, there may be minimal deviations.
Degree of protection	IP20

### Input data

Signal input	Active current input, intrinsically safe
Current input signal	4 mA ... 20 mA
Transmitter supply voltage	> 16 V (20 mA)
	> 15.3 V (22.5 mA)
Polarization and surge protection	Yes
Signal input	Passive current input, intrinsically safe
Current input signal	0 mA ... 20 mA
	4 mA ... 20 mA
Voltage drop	< 3.5 V

### Output data

Signal output	Current output (active and passive)
Current output signal	4 mA ... 20 mA (active)
	4 mA ... 20 mA (14 ... 26 V ext. source voltage)
Transmission Behavior	1:1 to input signal
Load/output load current output	< 1000 Ω (20 mA)
	< 825 Ω (24 mA)
Output ripple	< 20 mV <sub>rms</sub>
Output behavior in the event of an error	0 mA (Cable break in the input)
	≥ 22.5 mA (Cable short-circuit in the input)
Signal output	Current output (active and passive)

# Power/input isolating amplifier - MACX MCR-EX-SL-RPSSI-I-SP - 2924016

## Technical data

### Output data

Current output signal	0 mA ... 20 mA (active)
	4 mA ... 20 mA (active)
	0 mA ... 20 mA (14 ... 26 V ext. source voltage)
	4 mA ... 20 mA (14 ... 26 V ext. source voltage)
Transmission Behavior	1:1 to input signal
Load/output load current output	< 1000 Ω (20 mA)
	< 825 Ω (24 mA)
Output ripple	< 20 mV <sub>rms</sub>
Output behavior in the event of an error	0 mA (Cable break in the input)
	0 mA (Cable short-circuit in the input)

### Power supply

Designation	Repeater power supply operation
Nominal supply voltage	24 V DC
Supply voltage range	19.2 V DC ... 30 V DC (24 V DC -20%...+25%)
Max. current consumption	< 76 mA (24 V DC / 20 mA / 1000 #)
Power consumption	< 1.1 W (24 V DC / 20 mA / 1000 #)
	< 1.8 W (20 mA / 1000 #)

### Connection data

Conductor cross section solid min.	0.2 mm <sup>2</sup>
Conductor cross section solid max.	1.5 mm <sup>2</sup>
Conductor cross section flexible min.	0.2 mm <sup>2</sup>
Conductor cross section flexible max.	1.5 mm <sup>2</sup>
Conductor cross section AWG min.	24
Conductor cross section AWG max.	16
Stripping length	8 mm
Connection method	Push-in connection

### General

No. of channels	1
Maximum transmission error	< 0.1 % (of final value)
Transmission error, typical	< 0.05 % (of final value)
Maximum temperature coefficient	< 0.01 %/K
Temperature coefficient, typical	< 0.004 %/K
Step response (10-90%)	< 200 μs (for jump 4 mA ... 20 mA, load 600)
	< 600 μs (for jump 0 mA ... 20 mA, load 600)
Status display	Green LED (supply voltage)
Flammability rating according to UL 94	V0

# Power/input isolating amplifier - MACX MCR-EX-SL-RPSSI-I-SP - 2924016

## Technical data

### General

Degree of pollution	2
Overvoltage category	II
Electromagnetic compatibility	Conformance with EMC Directive 2004/108/EC
Housing material	PA 66-FR
Color	green
Designation	Input/output/power supply
Electrical isolation	300 V <sub>rms</sub> (Rated insulation voltage (overvoltage category II; degree of pollution 2, safe isolation as per EN 61010-1))
	2.5 kV (50 Hz, 1 min., test voltage)
Designation	Input/output
Electrical isolation	375 V (Peak value in accordance with EN 60079-11)
Designation	Input/power supply
Electrical isolation	375 V (Peak value in accordance with EN 60079-11)
Conformance	CE-compliant, additionally EN 61326
ATEX	# II (1) G [Ex ia Ga] IIC/IIB
	# II (1) D [Ex ia Da] IIIC
	# II 3 (1) G Ex nA [ia Ga] IIC/IIB T4 Gc
	# I (M1) [Ex ia Ma] I
IECEX	[Ex ia Ga] IIC/IIB
	[Ex ia Da] IIIC
	Ex nA [ia Ga] IIC/IIB T4 Gc
	[Ex ia Ma] I
UL, USA / Canada	UL 61010 Listed
	Class I Div 2; IS for Class I, II, III Div 1
Functional Safety (SIL)	SIL 2

### Data communication (bypass)

HART function	Yes
Protocols supported	HART

### Safety characteristic data

Integrity requirement	IEC 61508 - Low demand
Equipment type	Type A
Safety Integrity Level (SIL)	Up to 2
Safe Failure Fraction (SFF)	90.7 %
$\lambda_{SU}$	$4.867 \times 10^{-7}$ (486.7 FIT)
$\lambda_{SD}$	0
$\lambda_{DU}$	$5 \times 10^{-8}$ (50 FIT)

# Power/input isolating amplifier - MACX MCR-EX-SL-RPSSI-I-SP - 2924016

## Technical data

### Safety characteristic data

$\lambda_{DD}$	0
Probability of a hazardous failure on demand (PFD <sub>AVG</sub> )	2.40 x 10 <sup>-4</sup> (1 year)
	4.76 x 10 <sup>-4</sup> (2 years)
	7.13 x 10 <sup>-4</sup> (3 years)
	9.50 x 10 <sup>-4</sup> (4 years)
	11.9 x 10 <sup>-4</sup> (5 years)
Diagnostic coverage (DC)	DC <sub>S</sub> = 0%, DC <sub>D</sub> = 0%
Integrity requirement	IEC 61508 - High demand
Equipment type	Type A
Safety Integrity Level (SIL)	Up to 2
Safe Failure Fraction (SFF)	90.7 %
$\lambda_{SU}$	4.867 x 10 <sup>-7</sup> (486.7 FIT)
$\lambda_{DU}$	5 x 10 <sup>-8</sup> (50 FIT)
$\lambda_{DD}$	0
Probability of a hazardous failure per hour (PFH <sub>D</sub> )	4,99 x 10 <sup>-8</sup>
Diagnostic coverage (DC)	DC <sub>S</sub> = 0%, DC <sub>D</sub> = 0%

### Safety data

Operation	Repeater power supply operation
Max. output voltage U <sub>o</sub>	25.2 V
Max. output current I <sub>o</sub>	93 mA
Max. output power P <sub>o</sub>	587 mW
Group	IIC
Max. external inductivity L <sub>o</sub>	2 mH
Max. external capacity C <sub>o</sub>	107 nF
Group	IIB
Max. external inductivity L <sub>o</sub>	4 mH
Max. external capacity C <sub>o</sub>	820 nF
Safety-related maximum voltage U <sub>m</sub>	253 V AC (125 V DC)
Operation	Signal conditioner operation
Input voltage U <sub>i</sub>	≤ 30 V
Input current I <sub>i</sub>	≤ 150 mA
Max. internal inductance L <sub>i</sub>	negligible
Max. internal capacitance C <sub>i</sub>	negligible

### EMC data

# Power/input isolating amplifier - MACX MCR-EX-SL-RPSSI-I-SP - 2924016

## Technical data

### EMC data

Designation	Electromagnetic RF field
Standards/regulations	EN 61000-4-3
Typical deviation from the measuring range final value	1 %
Designation	Fast transients (burst)
Standards/regulations	EN 61000-4-4
Typical deviation from the measuring range final value	1 %
Designation	Conducted interferences
Standards/regulations	EN 61000-4-6
Typical deviation from the measuring range final value	1 %

### Standards and Regulations

Electromagnetic compatibility	Conformance with EMC Directive 2004/108/EC
Designation	Electromagnetic RF field
Standards/regulations	EN 61000-4-3
	EN 61000-4-4
Designation	Conducted interferences
Standards/regulations	EN 61000-4-6
Flammability rating according to UL 94	V0
Conformance	CE-compliant, additionally EN 61326
ATEX	# II (1) G [Ex ia Ga] IIC/IIB
	# II (1) D [Ex ia Da] IIIC
	# II 3 (1) G Ex nA [ia Ga] IIC/IIB T4 Gc
	# I (M1) [Ex ia Ma] I
IECEX	[Ex ia Ga] IIC/IIB
	[Ex ia Da] IIIC
	Ex nA [ia Ga] IIC/IIB T4 Gc
	[Ex ia Ma] I
UL, USA / Canada	UL 61010 Listed
	Class I Div 2; IS for Class I, II, III Div 1
Group	IIC
	IIB

## Classifications

### eCl@ss

eCl@ss 4.0	27210121
eCl@ss 4.1	27210121
eCl@ss 5.0	27210121

# Power/input isolating amplifier - MACX MCR-EX-SL-RPSSI-I-SP - 2924016

## Classifications

### eCl@ss

eCl@ss 5.1	27210121
eCl@ss 6.0	27210121
eCl@ss 7.0	27210121
eCl@ss 8.0	27210120

### ETIM

ETIM 2.0	EC001431
ETIM 3.0	EC001596
ETIM 4.0	EC001596
ETIM 5.0	EC002653

### UNSPSC

UNSPSC 6.01	30211506
UNSPSC 7.0901	39121008
UNSPSC 11	39121008
UNSPSC 12.01	39121008
UNSPSC 13.2	39121008

## Approvals

### Approvals

---

#### Approvals

UL Listed / cUL Listed / Functional Safety / GL / EAC / BV / cULus Listed

---

#### Ex Approvals

IECEX / ATEX / UL Listed / cUL Listed / EAC Ex / cULus Listed

---

#### Approvals submitted

---

### Approval details

UL Listed
-----------

# Power/input isolating amplifier - MACX MCR-EX-SL-RPSSI-I-SP - 2924016

## Approvals

cUL Listed

Functional Safety

GL

EAC

BV

cULus Listed

## Drawings

Block diagram

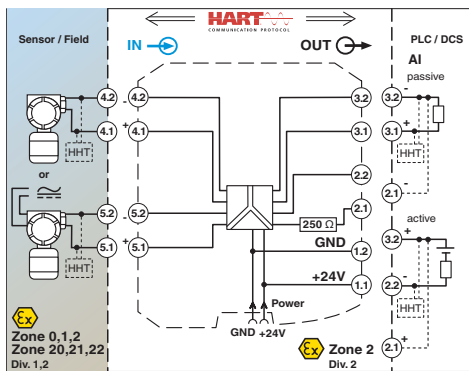

Dimensional drawing

