

## MPS 5/06 S F3 TN B B

**Weidmüller Interface GmbH & Co. KG**

Klingenbergstraße 26

D-32758 Detmold

Germany

www.weidmueller.com

### Product image

**SNAP IN**

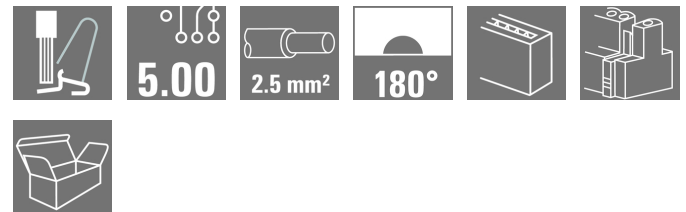

### OMNIMATE® 4.0 - the next evolution step

OMNIMATE® 4.0 follows the trend of One Cable Technology (OCT). The modular concept enables the fast configuration of hybrid interfaces, which transmit data, signals and energy in a single connector. As a result, you can reduce the cabling effort in a wide variety of applications, simplify maintenance and accelerate automation processes. The unique SNAP IN connection is the backbone and speeds up the wiring process.

### The fastest connection yet

- Fast, safe, and tool-free wiring due to unique SNAP IN connection
- Ready for Robot through "wire ready" delivery with open clamping point
- Optical and acoustic feedback indicates proper wiring

### Create your own configuration

- Flexible configuration and ordering via the Weidmüller Configurator (WMC)
- Dispatch within three days – even for individually configured products
- Automatic offer preparation for the configured product

### Simply configuration of modular hybrid connectors

- Flexible combination options for power, signal and data transmission
- Future-proof Single-Pair Ethernet technology

### General ordering data

Version	PCB plug-in connector, female plug, Pitch in mm (P): 5.00 mm, Number of poles: 6, 180°, Box
Order No.	<a href="#">2741710000</a>
Type	MPS 5/06 S F3 TN B B
GTIN (EAN)	4064675055235
Qty.	60 pc(s).
Product data	IEC: 400 V / 26.8 A / 0.5 - 4 mm <sup>2</sup> UL: 300 V / 18.5 A / AWG 20 - AWG 12
Packaging	Box

Creation date March 12, 2024 12:25:20 PM CET

Catalogue status 09.03.2024 / We reserve the right to make technical changes.

## MPS 5/06 S F3 TN B B

Weidmüller Interface GmbH &amp; Co. KG

Klingenbergstraße 26

D-32758 Detmold

Germany

www.weidmueller.com

## Technical data

## Dimensions and weights

Depth	34 mm	Depth (inches)	1.339 inch
Height	17.5 mm	Height (inches)	0.689 inch
Width	30.8 mm	Width (inches)	1.213 inch
Net weight	13.484 g		

## System Parameters

Product family	OMNIMATE 4.0
Type of connection	Field connection
Wire connection method	SNAP IN
Pitch in mm (P)	5 mm
Pitch in inches (P)	0.197 "
Conductor outlet direction	180°
Number of poles	6
L1 in mm	25 mm
L1 in inches	0.984 "
Number of rows	1
Pin series quantity	1
Touch-safe protection acc. to DIN VDE 57 106	Safe from finger touch
Touch-safe protection acc. to DIN VDE 0470	IP 20
Protection degree	IP20
Volume resistance	≤5 mΩ
Stripping length	9 mm
Stripping length tolerance	min. 8 mm max. 10 mm
Plugging cycles	25
Plugging force/pole, max.	8.5 N
Pulling force/pole, max.	8.5 N

## Material data

Insulating material	PBT GF	Colour	black
Colour chart (similar)	RAL 9011	Insulating material group	I
Comparative Tracking Index (CTI)	≥ 600	UL 94 flammability rating	V-0
Contact material	Cu-alloy	Contact surface	tinned
Storage temperature, min.	-25 °C	Storage temperature, max.	55 °C
Operating temperature, min.	-50 °C	Operating temperature, max.	125 °C

## Conductors suitable for connection

Clamping range, min.	0.34 mm <sup>2</sup>
Clamping range, max.	4 mm <sup>2</sup>
Solid, min. H05(07) V-U	0.5 mm <sup>2</sup>
Solid, max. H05(07) V-U	2.5 mm <sup>2</sup>
Flexible, min. H05(07) V-K	0.5 mm <sup>2</sup>
Flexible, max. H05(07) V-K	4 mm <sup>2</sup>
w. plastic collar ferrule, DIN 46228 pt 4, min.	0.34 mm <sup>2</sup>
w. plastic collar ferrule, DIN 46228 pt 4, max.	2.5 mm <sup>2</sup>
w. wire end ferrule, DIN 46228 pt 1, min.	0.34 mm <sup>2</sup>
w. wire end ferrule, DIN 46228 pt 1, max.	2.5 mm <sup>2</sup>

Creation date March 12, 2024 12:25:20 PM CET

## MPS 5/06 S F3 TN B B

**Weidmüller Interface GmbH & Co. KG**  
 Klingenbergstraße 26  
 D-32758 Detmold  
 Germany

www.weidmueller.com

## Technical data

Outer diameter of insulation, max.	4 mm			
Clampable conductor	Cross-section for conductor connection	nominal	0.34 mm <sup>2</sup>	
	wire end ferrule	Stripping length	nominal 10 mm	
		Recommended wire-end ferrule	<a href="#">H0.34/12 TK</a>	
	Cross-section for conductor connection	nominal	0.5 mm <sup>2</sup>	
	wire end ferrule	Stripping length	nominal 12 mm	
		Recommended wire-end ferrule	<a href="#">H0.5/16 OR</a>	
		Stripping length	nominal 10 mm	
		Recommended wire-end ferrule	<a href="#">H0.5/10</a>	
	Cross-section for conductor connection	nominal	0.75 mm <sup>2</sup>	
	wire end ferrule	Stripping length	nominal 12 mm	
		Recommended wire-end ferrule	<a href="#">H0.75/16 W</a>	
		Stripping length	nominal 10 mm	
		Recommended wire-end ferrule	<a href="#">H0.75/10</a>	
	Cross-section for conductor connection	nominal	1 mm <sup>2</sup>	
	wire end ferrule	Stripping length	nominal 12 mm	
		Recommended wire-end ferrule	<a href="#">H1.0/16 GE</a>	
		Stripping length	nominal 10 mm	
		Recommended wire-end ferrule	<a href="#">H1.0/10</a>	
	Cross-section for conductor connection	nominal	1.5 mm <sup>2</sup>	
	wire end ferrule	Stripping length	nominal 12 mm	
		Recommended wire-end ferrule	<a href="#">H1.5/16 R</a>	
		Stripping length	nominal 10 mm	
		Recommended wire-end ferrule	<a href="#">H1.5/10</a>	
	Cross-section for conductor connection	nominal	2.5 mm <sup>2</sup>	
wire end ferrule	Stripping length	nominal 10 mm		
	Recommended wire-end ferrule	<a href="#">H2.5/15D BL</a>		
	Stripping length	nominal 10 mm		
	Recommended wire-end ferrule	<a href="#">H2.5/10</a>		

Reference text The outside diameter of the plastic collar should not be larger than the pitch (P). Length of ferrules is to be chosen depending on the product and the rated voltage.

### Rated data acc. to IEC

tested acc. to standard	IEC 60664-1, IEC 61984	Rated current, min. number of poles (Tu=20°C)	26.8 A
Rated current, max. number of poles (Tu=20°C)	19.7 A	Rated current, min. number of poles (Tu=40°C)	23.1 A
Rated current, max. number of poles (Tu=40°C)	16.9 A	Rated voltage for surge voltage class / pollution degree II/2	400 V
Rated voltage for surge voltage class / pollution degree III/2	320 V	Rated voltage for surge voltage class / pollution degree III/3	250 V
Rated impulse voltage for surge voltage class/ pollution degree II/2	4 kV	Rated impulse voltage for surge voltage class/ pollution degree III/2	4 kV
Rated impulse voltage for surge voltage class/ contamination degree III/3	4 kV		

## MPS 5/06 S F3 TN B B

**Weidmüller Interface GmbH & Co. KG**  
 Klingenbergstraße 26  
 D-32758 Detmold  
 Germany

www.weidmueller.com

## Technical data

### Rated data acc. to UL 1059

Institute (cURus)



Certificate No. (cURus)

E60693

Rated voltage (Use group B / UL 1059)	300 V	Rated voltage (Use group C / UL 1059)	150 V
Rated voltage (Use group D / UL 1059)	300 V	Rated current (Use group B / UL 1059)	18.5 A
Rated current (Use group C / UL 1059)	18.5 A	Rated current (Use group D / UL 1059)	18.5 A
Wire cross-section, AWG, min.	AWG 20	Wire cross-section, AWG, max.	AWG 12
Reference to approval values	Specifications are maximum values, details - see approval certificate.		

### Classifications

ETIM 6.0	EC002638	ETIM 7.0	EC002638
ETIM 8.0	EC002638	ETIM 9.0	EC002638
ECLASS 9.0	27-44-03-09	ECLASS 9.1	27-44-03-09
ECLASS 10.0	27-44-03-09	ECLASS 11.0	27-46-02-02
ECLASS 12.0	27-46-02-02	ECLASS 13.0	27-46-02-02

### Important note

IPC conformity	Conformity: The products are developed, manufactured and delivered according international recognized standards and norms and comply with the assured properties in the data sheet resp. fulfill decorative properties in accordance with IPC-A-610 "Class 2". Further claims on the products can be evaluated on request.
Notes	<ul style="list-style-type: none"> <li>Rated current related to rated cross-section &amp; min. No. of poles.</li> <li>P on drawing = pitch</li> <li>Rated data refer only to the component itself. Clearance and creepage distances to other components are to be designed in accordance with the relevant application standards.</li> <li>Wire end ferrule without plastic collar to DIN 46228/1</li> <li>In accordance with IEC 61984, OMNIMATE-connectors are connectors without breaking capacity (COC). During designated use, connectors are not allowed to be engaged or disengaged when live or under load</li> <li>Long term storage of the product with average temperature of 50 °C and maximum humidity 70%, 36 months</li> </ul>

### Approvals

Approvals



UL File Number Search	UL Website
Certificate No. (cURus)	E60693

**MPS 5/06 S F3 TN B B****Weidmüller Interface GmbH & Co. KG**

Klingenbergstraße 26

D-32758 Detmold

Germany

[www.weidmueller.com](http://www.weidmueller.com)**Technical data****Downloads**

Approval/Certificate/Document of Conformity	<a href="#">CoC_cURus_E60693_MPS_MHS_202207.pdf</a> <a href="#">Declaration of the Manufacturer</a>
Engineering Data	<a href="#">CAD data – STEP</a>
Product Change Notification	<a href="#">20210526 Technical change to MPS 5 and MHS 5 H</a> <a href="#">20210526 Technische Änderung zu MPS 5 und MHS 5 H</a> <a href="#">20210602 Technical change to MPS 5</a> <a href="#">20210602 Technische Änderung zu MPS 5</a> <a href="#">20230105 MPS 5 – Change of top-fixation</a> <a href="#">20230105 MPS 5 – Optimierung der Top-Fixierung</a>
User Documentation	<a href="#">Assembly instructions MPS 7S/5 EN DE</a>
Catalogues	<a href="#">Catalogues in PDF-format</a>

**MPS 5/06 S F3 TN B B**

**Weidmüller Interface GmbH & Co. KG**  
 Klingenbergstraße 26  
 D-32758 Detmold  
 Germany

www.weidmueller.com

**Drawings**

**Product image**

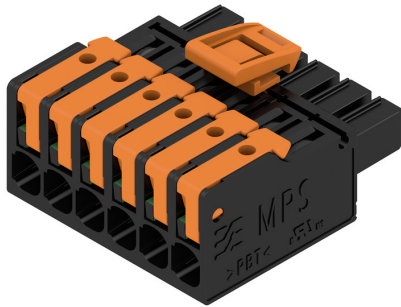

**Dimensional drawing**

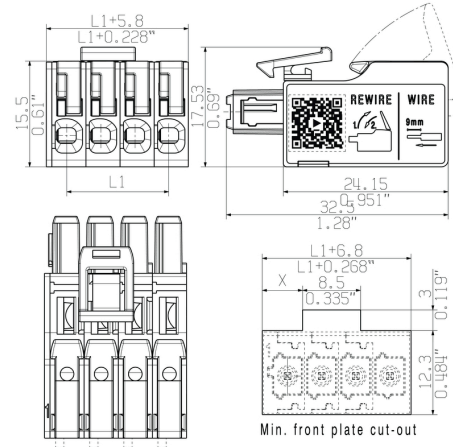

**Derating curve**

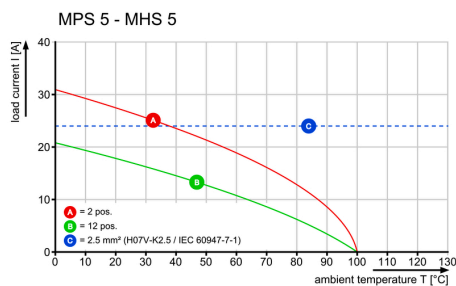

**Product benefits**



Fastest connection technology SNAP IN

**Product benefits**



Acoustic and visual feedback

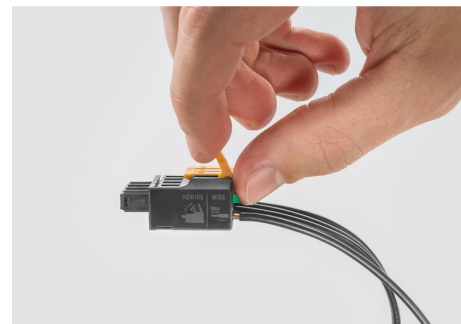

Allgemeinguetliche Kundenzeichnung, aktueller Stand nur auf Anfrage  
 General customer drawing, topical version only if required

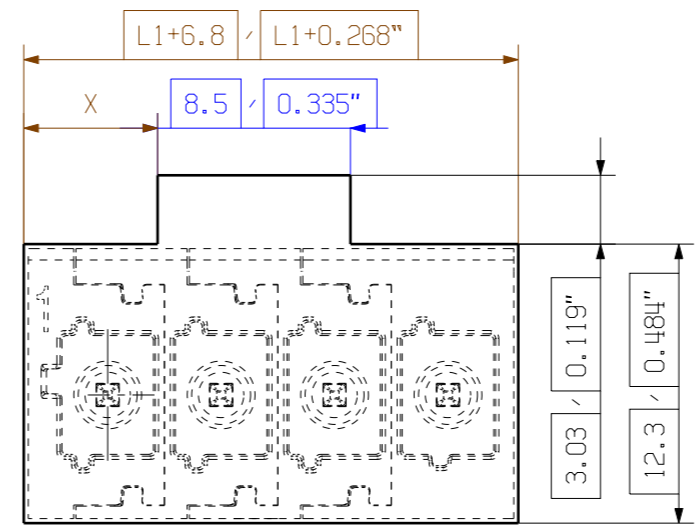
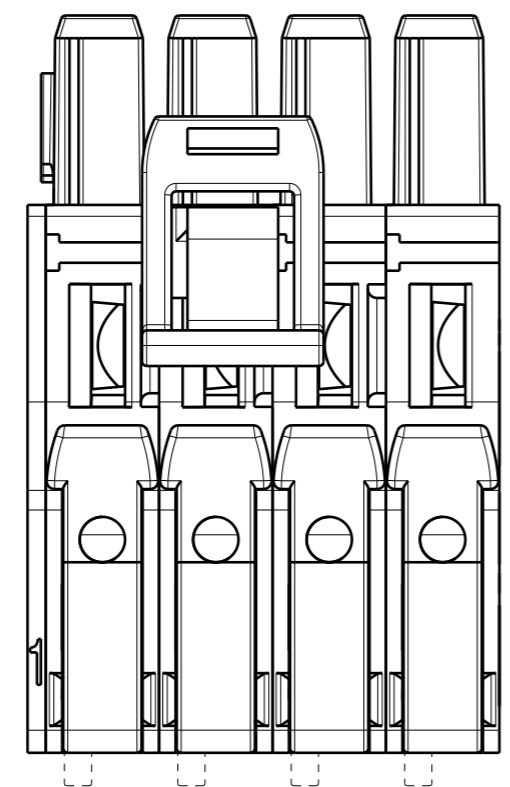
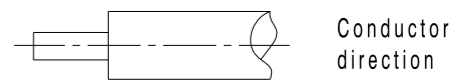
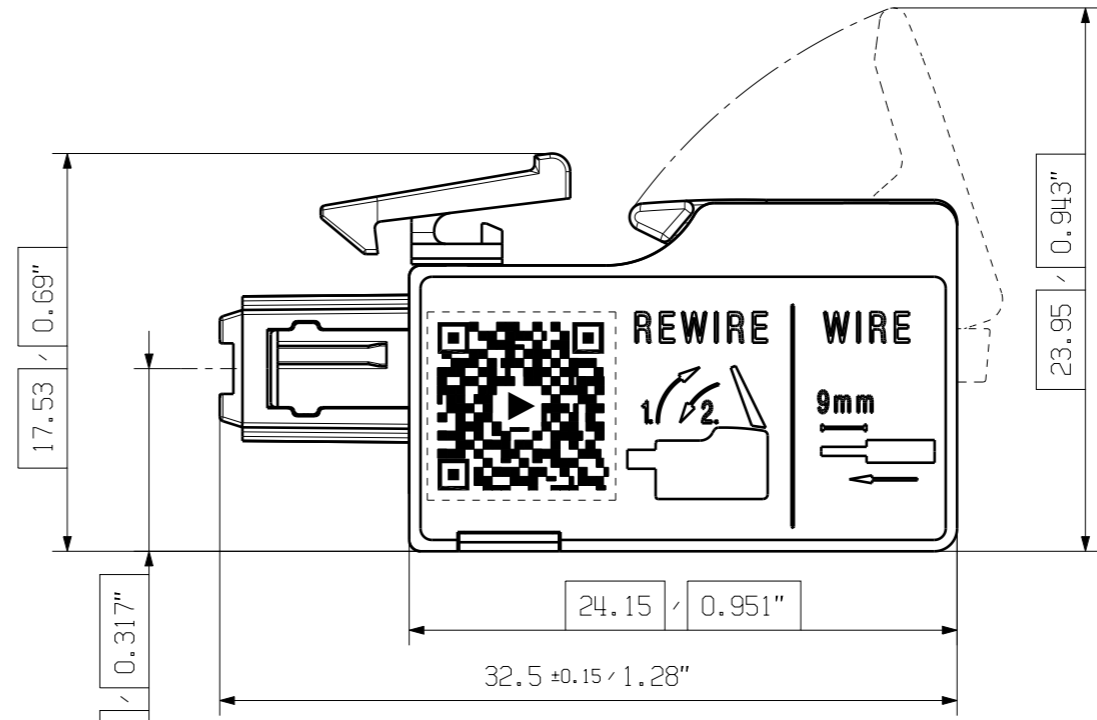
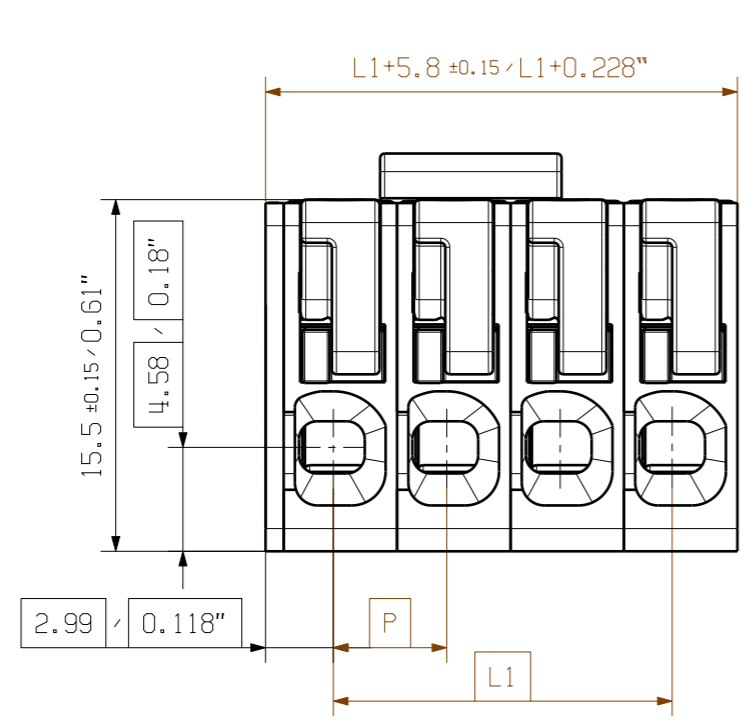

Min. front plate cut-out

P = Pitch (5mm/0.2")  
 Further dim. & info. see data sheet

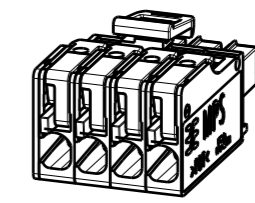

12	55.00	2.165	25.30	0.996
11	50.00	1.969	25.30	0.996
10	45.00	1.772	20.30	0.799
9	40.00	1.575	20.30	0.799
8	35.00	1.378	15.30	0.602
7	30.00	1.181	15.30	0.602
6	25.00	0.984	10.30	0.406
5	20.00	0.787	10.30	0.406
4	15.00	0.591	5.30	0.209
3	10.00	0.394	5.30	0.209
2	5.00	0.197	0.30	0.012
n Poles	L1 [mm]	L1 [inch]	X [mm]	X [inch]

The reproduction, distribution and utilization of this document as well as the communication of its contents to others without explicit authorization is prohibited. Offenders will be held liable for the payment of damages. Weidmüller exclusively reserves the right to file for patents, utility models or designs.

© Weidmüller Interface GmbH & Co. KG

For the mounting of PCBs, it should be noted that the rated data given in the catalogue relates only to the connection elements. The necessary creepage and clearance paths must be observed in connection with the respective applicant in accordance to VDE 0110. The current-carrying capacity and pitch tolerance is to be determined according to DIN IEC 326 part 3 very fine.

Weidmüller connectors are tested to the DIN VDE 0627 standard, and are valid for its field of application. Provided that the connectors are used to the intended purpose, all requirements with respect to the occurring of electrical, mechanical, thermic and corrosive stress will be satisfied.

The dimensions and tolerances specified on the customer drawing reflect the geometry in dry condition and do not consider humidity and temperature effects. A specific agreement / specification between manufacturer and customer is required if certain dimensions including tolerances must be guaranteed under environmental conditions in the storage phase or the application (e.g. high humidity and / or temperature).



General Tolerances: <input type="checkbox"/> WN700144-W.. <input type="checkbox"/> WN 212010 <input type="checkbox"/> ISO 2768-mK		Tolerances ISO 8015	
Changes: EC00007363		72561	
Mat. No. (SAP)		Drawing no. 7	
Drawings Assembly		Scale: 3:1 Sheet 4 / 4	
Drawn	Reger, Marc	<p><b>MPS 5/... TN ...</b>                  FEMALE PLUG                  BUCHSENSTECKER</p>	
Responsible	Schmitz, Till		
Approved	Schmitz, Till		
		08.09.2022	