

Safety relays - PSR-MC72-2NO-1DO-24DC-SP



2702097

<https://www.phoenixcontact.com/de/produkte/2702097>

Please be informed that the data shown in this PDF document is generated from our Online Catalog. Please find the complete data in the user documentation. Our General Terms of Use for Downloads are valid.



Safety relay for emergency stop, safety doors, light grid up to SIL 3, Cat. 4, PL e, 1- or 2-channel operation, cross-circuit detection, can be retriggered, fall back/on delay 0.2 s ... 60 s, 2 enabling current paths, $U_S = 24 \text{ V DC}$, pluggable Push-in terminal block

Your advantages

- Up to Cat. 4/PL e in accordance with EN ISO 13849-1, SIL 3 in accordance with IEC 62061
- Low housing width of just 12.5 mm
- 1- and 2-channel control
- 2 enabling current paths, 1 digital signal output
- Manually monitored and automatic activation in a single device

Commercial Data

Item number	2702097
Packing unit	1 pc
Minimum order quantity	1 pc
Sales Key	G1 - Relais
Product Key	DNA181
Catalog Page	Page 226 (C-6-2019)
GTIN	4046356952491
Weight per Piece (including packing)	160,34 g
Weight per Piece (excluding packing)	126,45 g
Customs tariff number	85371098
Country of origin	DE

Technical Data

Notes

Utilization restriction

EMC note	EMC: class A product, see manufacturer's declaration in the download area
----------	---

Product properties

Product type	Safety relays
Application	Emergency stop
	Safety door
	Light grid
Relay type	Electromechanical relay with force-guided contacts in accordance with IEC/EN 61810-3

Insulation characteristics

Overvoltage category	III
----------------------	-----

Times

Typical response time	< 35 ms (automatic start)
	< 30 ms (manual, monitored start)
Typical release time	< 25 ms (when controlled via S12 (only for undelayed contact 13/14))
	< 5 ms (when interrupted via A1; applicative deactivation via A1/A2 is not permitted)
Delay time range	0.2 s ... 60 s \pm 5 % (can be set for 27/28)
Restart time	< 1 s (Boot time)

Electrical properties

Maximum power dissipation for nominal condition	5.78 W (at $U_S = 30$ V, $I_L^2 = 72$ A ²)
Nominal operating mode	100% operating factor
Rated insulation voltage	250 V AC
Rated insulation voltage	250 V AC
Rated surge voltage/insulation	Basic insulation 4 kV: between all current paths and housing Safe isolation, reinforced insulation 6 kV: between (A1, A2, S11, S12, S21, S22, S34, M1) and enabling current path (13/14) between (A1, A2, S11, S12, S21, S22, S34, M1) and enabling current path (27/28) between enabling current paths

Supply

Designation	A1/A2
Rated control circuit supply voltage U_S	19.2 V DC ... 30 V DC
Rated control circuit supply voltage U_S	24 V DC -20 % / +25 %
Rated control supply current I_S	typ. 60 mA
Power consumption at U_S	typ. 1.44 W

Safety relays - PSR-MC72-2NO-1DO-24DC-SP



2702097

<https://www.phoenixcontact.com/de/produkte/2702097>

Inrush current	typ. 25 A ($\Delta t = 10 \mu s$ at U_S)
Filter time	10 ms (For the logic. At A1 in the event of voltage dips at U_S)
Protective circuit	Surge protection; Suppressor diode
	Protection against polarity reversal for rated control circuit supply voltage

Input data

Digital: Sensor circuit (S12, S22)

Description of the input	safety-related sensor inputs
Number of inputs	2
Input voltage range "0" signal	0 V DC ... 5 V DC
Input current range "0" signal	0 mA ... 2 mA
Inrush current	< 11 mA (typically with U_S)
Filter time	max. 3 ms (Test pulse width of low test pulses)
	min. 21 ms (Test pulse rate for low test pulse)
	Test pulse rate = 7 x Test pulse width
Concurrence	∞
Limit frequency	min. 0 Hz
	max. 1 Hz
Max. permissible overall conductor resistance	150 Ω
Current consumption	< 4.1 mA (typically with U_S)

Digital: Start circuit (S34)

Description of the input	non-safety-related
Number of inputs	1
Inrush current	< 8.6 mA (typically with U_S)
Filter time	max. 3 ms (Test pulse width of low test pulses)
	min. 21 ms (Test pulse rate for low test pulse)
	Test pulse rate = 7 x Test pulse width
Max. permissible overall conductor resistance	150 Ω
Voltage at input/start and feedback circuit	24 V DC -20 % / +25 %
Current consumption	< 3.2 mA (typically with U_S)

Output data

Relay: Enabling current paths (13/14, 27/28)

Output description	safety-related N/O contacts
Number of outputs	1 (undelayed)
	1 (delayed)
Contact type	2 enabling current paths
Contact material	AgSnO ₂
Switching voltage	min. 12 V AC/DC
	max. 250 V AC (Observe the load curve)
Switching capacity	min. 60 mW
Inrush current	min. 3 mA

Safety relays - PSR-MC72-2NO-1DO-24DC-SP



2702097

<https://www.phoenixcontact.com/de/produkte/2702097>

	max. 6 A
Limiting continuous current	6 A (observe derating)
Sq. Total current	72 A ² (observe derating)
Mechanical service life	10x 10 ⁶ cycles
Output fuse	6 A gL/gG (N/O contact) 4 A gL/gG (for low-demand applications)

Signal: M1

Output description	PNP non-safety-related
Number of outputs	1
Voltage	approx. 23 V DC (U _S - 1 V)
Current	max. 100 mA
Maximum inrush current	500 mA (Δt = 1 ms at U _S)
Short-circuit protection	Yes

Connection data

Connection technology

pluggable	yes
-----------	-----

Conductor connection

Connection method	Push-in connection
Conductor cross section solid	0.2 mm ² ... 1.5 mm ²
Conductor cross section flexible	0.2 mm ² ... 1.5 mm ²
Conductor cross section, flexible, with ferrule, with plastic sleeve	0.25 mm ² ... 1.5 mm ² (only together with CRIMPFOX 6)
Conductor cross section flexible, with ferrule without plastic sleeve	0.25 mm ² ... 1.5 mm ² (only together with CRIMPFOX 6)
Conductor cross-section AWG	24 ... 16
Stripping length	8 mm

LED signaling

Status display	5 x bi-color LED
----------------	------------------

Dimensions

Width	12.5 mm
Height	116.6 mm
Depth	114.5 mm

Material specifications

Housing material	Polyamide
Color (Housing)	yellow (1018)

Characteristics

Safety data

Stop category	0
---------------	---

Safety relays - PSR-MC72-2NO-1DO-24DC-SP



2702097

<https://www.phoenixcontact.com/de/produkte/2702097>

	1
--	---

Safety data: EN ISO 13849

Category	4
Performance level (PL)	e

Safety data: IEC 61508 - High demand

Equipment type	Type B
Safety Integrity Level (SIL)	3
Probability of a hazardous failure per hour (PFH _D)	1.5 x 10 ⁻⁹ (4 A DC13; 5 A AC15; 8760 switching cycles/year)
Proof test interval	240 Months
Duration of use	240 Months

Environmental and real-life conditions

Ambient conditions

Degree of protection	IP20
Min. degree of protection of inst. location	IP54
Ambient temperature (operation)	-35 °C ... 60 °C (observe derating)
Ambient temperature (storage/transport)	-40 °C ... 85 °C
Maximum altitude	≤ 2000 m (Above sea level)
Max. permissible humidity (storage/transport)	75 % (on average, 85% infrequently, non-condensing)
Max. permissible relative humidity (operation)	75 % (on average, 85% infrequently, non-condensing)
Shock	15g
Vibration (operation)	10 Hz ... 150 Hz, 2g

Approval data

CE

Certificate	CE-compliant
-------------	--------------

Standards and regulations

Air clearances and creepage distances between the power circuits

Standards/regulations	DIN EN 50178
-----------------------	--------------

Mounting

Mounting type	DIN rail mounting
Assembly instructions	See derating curve
Mounting position	vertical or horizontal

Safety relays - PSR-MC72-2NO-1DO-24DC-SP



2702097

<https://www.phoenixcontact.com/de/produkte/2702097>

Drawings

Block diagram

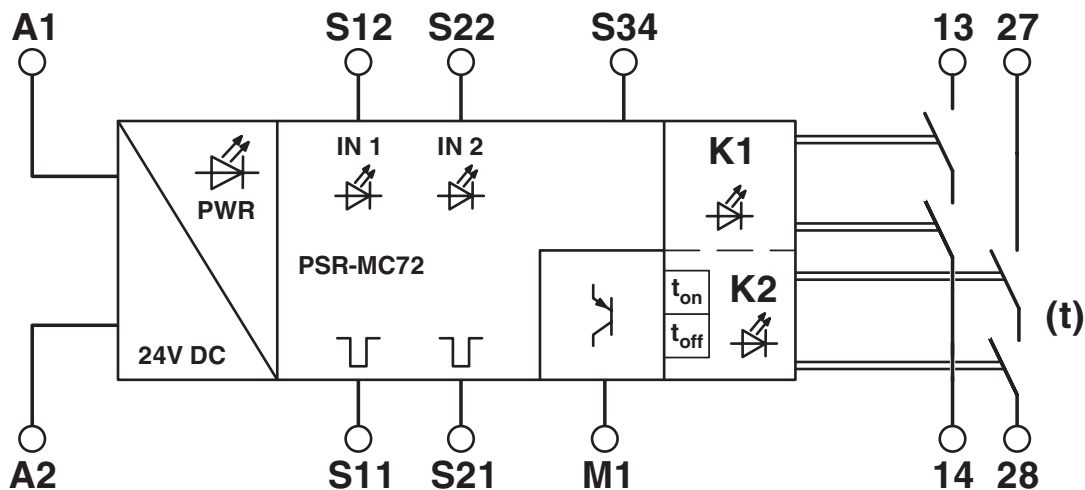

Block diagram

Circuit diagram

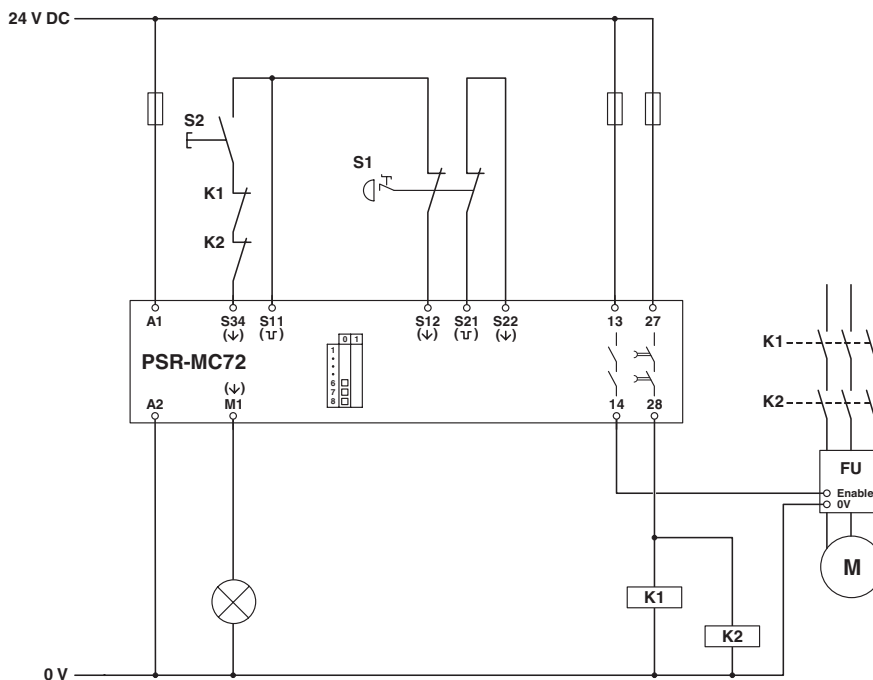

Safety relays - PSR-MC72-2NO-1DO-24DC-SP



2702097

<https://www.phoenixcontact.com/de/produkte/2702097>

Approvals



UL Listed

Approval ID: FILE E 140324



cUL Listed

Approval ID: FILE E 140324



Functional Safety

Approval ID: 01/205/5486.00/16

cULus Listed

Safety relays - PSR-MC72-2NO-1DO-24DC-SP



2702097

<https://www.phoenixcontact.com/de/produkte/2702097>

Classifications

ECLASS

ECLASS-9.0	27371819
ECLASS-10.0.1	27371819
ECLASS-11.0	27371819

ETIM

ETIM 8.0	EC001449
----------	----------

UNSPSC

UNSPSC 21.0	39122200
-------------	----------

Safety relays - PSR-MC72-2NO-1DO-24DC-SP



2702097

<https://www.phoenixcontact.com/de/produkte/2702097>

Environmental Product Compliance

REACH SVHC	Lead 7439-92-1
China RoHS	Environmentally Friendly Use Period = 50 years
	For information on hazardous substances, refer to the manufacturer's declaration available under "Downloads"

Phoenix Contact 2023 © - all rights reserved

<https://www.phoenixcontact.com>

PHOENIX CONTACT Deutschland GmbH

Flachsmarktstraße 8

D-32825 Blomberg

+49 52 35/3-1 20 00

info@phoenixcontact.de