



# More Precision.

**wire**SENSOR

Draw-wire displacement sensors





- Robust aluminium profile housing
- Customized versions for OEM
- Potentiometer, current and voltage output

Model P115 (Measuring range 3000/4000/5000mm)

Output UI

Output P

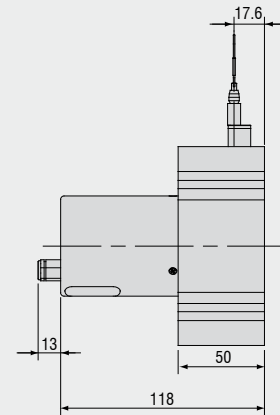
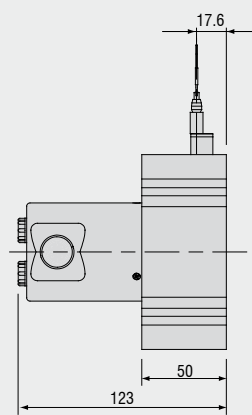
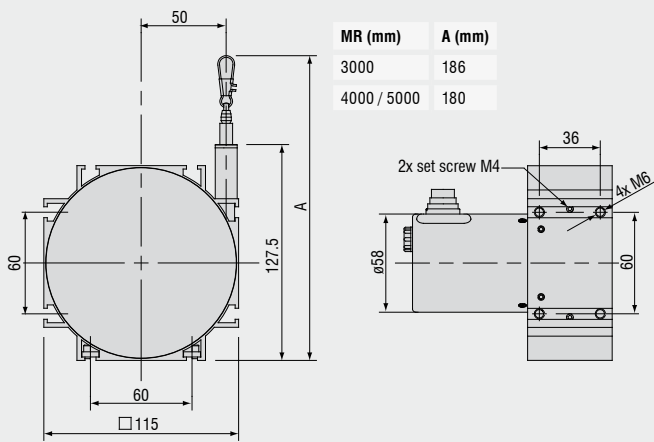

Model P115 (Measuring ranges 7500/10000/15000mm)

MR (mm)	A (mm)	B (mm)
7500	37	153
10000	44.5	198
15000	60.5	228

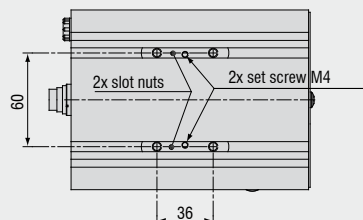
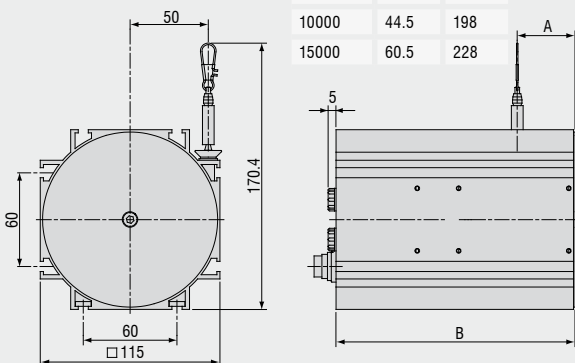





- Robust aluminium profile housing
- Customized versions for OEM
- Incremental/absolute encoder

### Model P115

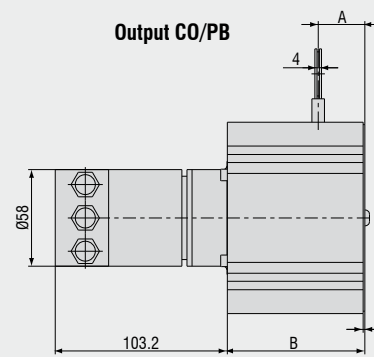
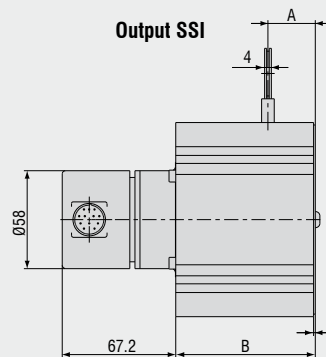
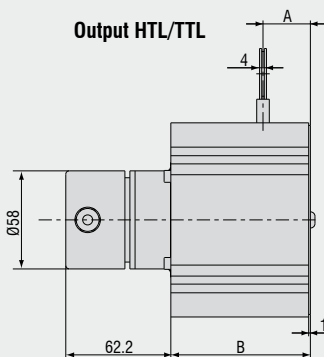
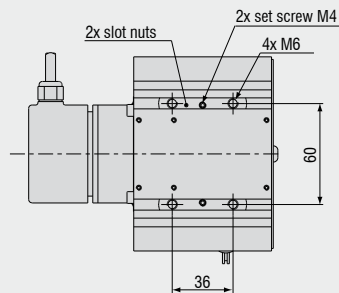
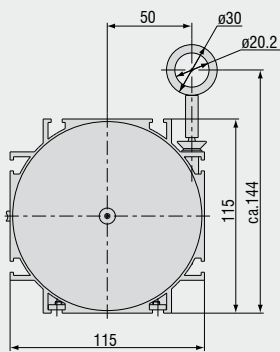

MR (mm)	A (mm)	B (mm)
5000	28	82.5
7500	37	105.5
10000	44.5	148.5
15000	61	180.5

Model		WDS-5000-P115	WDS-7500-P115	WDS-10000-P115	WDS-15000-P115
Measuring range		5000mm	7500mm	10000mm	15000mm
Output		HTL/ TTL/ SSI/ PB/ CO			
Linearity	±0.01% FSO	-	-	±1mm	±1.5mm
	±0.02% FSO	±1mm	±1.5mm	-	-
Resolution	HTL,TTL	0.105mm (9.52 Pulses/mm)			
	SSI, PB, CO	0.038mm			
Sensor element		incremental/absolute encoder			
Temperature range		-20 ... +80°C			
Material	housing	aluminium			
	draw wire	coated polyamid stainless steel (ø 1.0mm)			
Sensor mounting		slot nuts			
Wire mounting		eyelet			
Wire acceleration		5g	6g	3g	3g
Wire retraction force (min)		4N	8N	8N	8N
Wire extension force (max)		16N	24N	21N	25N
Protection class		IP 65 (only if connected)			
Vibration		20g, 20Hz - 2kHz			
Mechanical shock		50g, 10ms			
Electrical connection	HTL/ TTL	integrated cable, radial, 1m long			
	SSI	flange connector, radial, 12-pin			
	PB/ CO	bus cover			
Weight		appr. 2kg	appr. 2.5kg	appr. 3.5kg	appr. 4.5kg

FSO = Full Scale Output

Specifications for digital outputs on page 44.

#### Article description

**WDS - 5000 - P115 - CR - TTL**

Output options:

HTL

TTL

CO: CANopen

PB: Profibus DP

SSI

Connection:

SR (Output SSI): radial plug

CR (Output HTL, TTL): integrated cable, radial, 1m

BH (Output CO, PB): bus cover

Model P115

Measuring range in mm

<b>WE-x-M4, WE-x-Clip</b>	Wire extension x=length
<b>TR1-WDS</b>	Pulley wheel, adjustable
<b>TR3-WDS</b>	Pulley wheel, fixed
<b>GK1-WDS</b>	Attachment head for M4
<b>MH1-WDS</b>	Magnetic holder for wire mounting
<b>MH2-WDS</b>	Magnetic holder for sensor mounting
<b>MT-60-WDS</b>	Mounting clamp for WDS-P60
<b>FC8</b>	Female connector for WDS, 8-pin
<b>FC8/90</b>	Female connector 90° for WDS
<b>PC 3/8</b>	Sensor cable, length 3 m
<b>PS 2010</b>	Power supply (chassis mounting 35 x 7.5 mm); input 120/230 VAC; output 24 VDC/2.5 A; L/B/H 120 x 20 x 40 mm
<b>WDS-MP60</b>	Mounting plate for P60 sensors

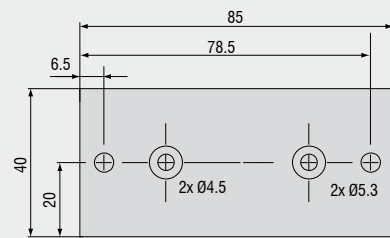
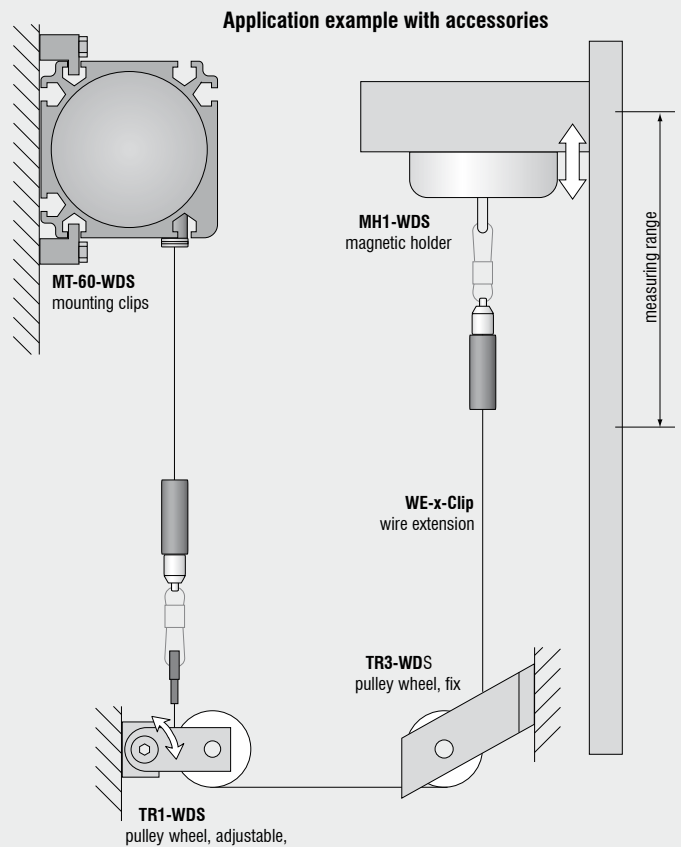

Mounting plate WDS-MP60

**Installation information:**

Wire attachment: The free return of the measurement wire is not permissible and it is essential that this is avoided during installation.

**Wire exit angle:**

When mounting a draw-wire displacement sensor, a straight wire exit ( $\pm 3^\circ$  tolerance) must be taken into account. If this tolerance is exceeded, increased material wear on the wire and at the wire aperture must be expected.

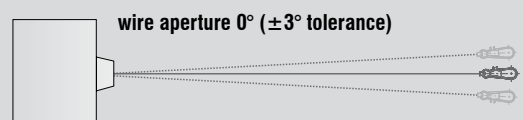

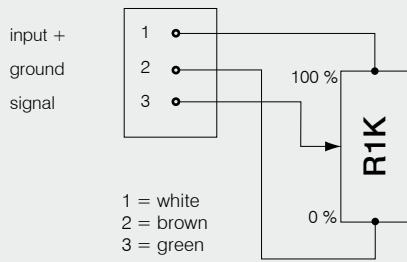

Potentiometric output (P)	
Supply voltage	max. 32VDC at 1kOhm / 1 Wmax
Resistance	1kOhm ±10% (potentiometer)
Temperature coefficient	±0.0025% FSO/°C
Sensitivity	depends on measuring range individually shown on test report

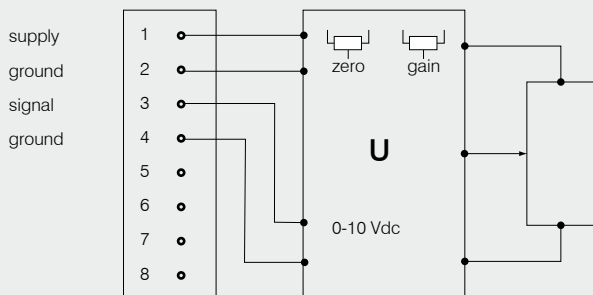

Voltage output (U)	
Supply voltage	14 ... 27VDC (non stabilized)
Current consumption	30mA max
Output voltage	0 ... 10VDC Option 0 ... 5 / ±5V
Load impedance	>5kOhm
Signal noise	0.5mV <sub>eff</sub>
Temperature coefficient	±0.005% FSO/°C
Electromagnetic compatibility (EMC)	EN 50081-2 EN 50082-2
Adjustment ranges	
Zero	±20 %FSO
Sensitivity	±20 %

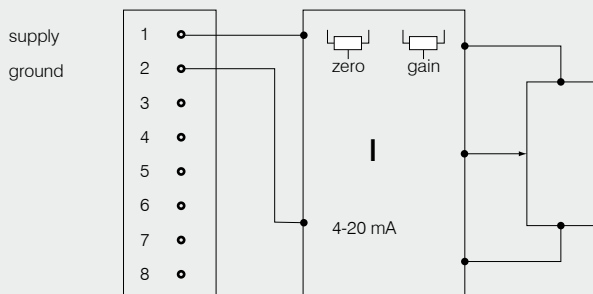

Current Output (I)	
Supply voltage	14 ... 27VDC (non stabilized)
Current consumption	35mA max
Output current	4 ... 20mA
Load	<600Ohm
Signal noise	<1.6µA <sub>eff</sub>
Temperature coefficient	±0.01% FSO/°C
Electromagnetic compatibility (EMC)	EN 50081-2 EN 50082-2
Adjustment ranges	
Zero	±18% FSO
Sensitivity	±15%

## Output specifications SSI

### Contact description

1 UB	Encoder power supply connection.
2 GND	Encoder ground connection. The voltage drawn to GND is UB.
3 Pulses +	Positive SSI pulse input. Pulse + forms a current loop with pulse -. A current of approx. 7 mA in direction of pulse + input generates a logical 1 in positive logic.
4 Data +	Positive, serial data output of the differential line driver. A High level at the output corresponds to logical 1 in positive logic.
5 ZERO	Zero setting input for setting a zero point at any desired point within the entire resolution. The zeroing process is triggered by a High pulse (pulse duration $\geq 100$ ms) and must take place after the rotating direction selection (UP/DOWN). For maximum interference immunity, the input must be connected to GND after zeroing.
6 Data -	Negative, serial data output of the differential line driver. A High level at the output corresponds to logical 0 in positive logic.
7 Pulses -	Negative SSI pulse input. Pulse - forms a current loop with pulse +. A current of approx. 7 mA in direction of pulse - input generates a logical 0 in positive logic.
8 / 10 $\overline{\text{DATAVALID}}$ $\overline{\text{DATAVALID MT}}$	Diagnosis outputs $\overline{\text{DV}}$ and $\overline{\text{DV MT}}$ Jumps in data word, e.g. due to defective LED or photoreceiver, are displayed via the $\overline{\text{DV}}$ output. In addition, the power supply of the multiturn sensor unit is monitored and the $\overline{\text{DV MT}}$ output is set when a specified voltage level is dropped below. Both outputs are Low-active, i.e. are switched through to GND in the case of an error.
9 UP/DOWN	UP/DOWN counting direction input. When not connected, this input is on High. UP/ $\overline{\text{DOWN}}$ -High means increasing output data with a clockwise shaft rotating direction when looking at the flange. UP/ $\overline{\text{DOWN}}$ -Low means increasing values with a counter-clockwise shaft rotating direction when looking at the flange.
11 / 12	Not in use

### Anschlussbelegung

Pin	Cable color	Assignment
1	brown	UB
2	black	GND
3	blue	Pulses +
4	beige	Data +
5	green	ZERO
6	yellow	Data -
7	violet	Pulses -
8	brown/yellow	$\overline{\text{DATAVALID}}$
9	pink	UP/ $\overline{\text{DOWN}}$
10	black/yellow	$\overline{\text{DATAVALID MT}}$
11	-	-
12	-	-

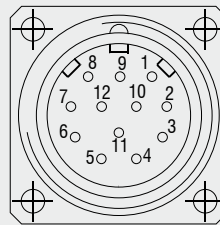

Please use leads twisted in pairs for extension cables.

### Inputs

Control signals UP/DOWN and Zero

Level High	> 0.7UB
Level Low	< 0.3UB

Connection: UP/DOWN input with 10kohms to UB, zeroing input with 10kohms to GND.

SSI pulse

Optocoupler inputs for electrical isolation

### Outputs

SSI data	RS485 driver
Diagnostic outputs	
Push-pull outputs are short-circuit-proof	
Level High	> UB -3.5V (with I = -20mA)
Level Low	$\leq 0.5V$ (with I = 20mA)

## CANopen features

Bus protocol	CANopen
Device profile	CANopen - CiA DSP 406, V 3.0
CANopen Features	Device Class 2, CAN 2.0B
Operating modes (with SDO progr.)	<p>Polling Mode (asynch, via SDO)</p> <p>Cyclic Mode (asynch-cyclic) The encoder cyclically sends the current process actual value without a request by a master. The cycle time can be parameterized for values between 1 and 65535 ms. Synch Mode (synch-cyclic) The encoder sends the current actual process value after receiving a synch telegram sent by a master. The synch counter in the encoder can be parameterized so that the position value is not sent until after a defined number of synch telegrams.</p> <p>Acyclic Mode (synch-acyclic)</p>
Preset value	With the "Preset" parameter the encoder can be set to a desired actual process value that corresponds to the defined axis position of the system. The offset value between the encoder zero point and the mechanical zero point of the system is saved in the encoder.
Rotating direction	With the operating parameter the rotating direction in which the output code is to increase or decrease can be parameterized. Scaling The steps per revolution and the total revolution can be parameterized.
Scaling:	The steps per revolution and the total revolution can be parameterized.
Diagnose	<p>The encoder supports the following error messages:</p> <ul style="list-style-type: none"> <li>- Position and parameter error</li> <li>- Lithium cell voltage at lower limit (Multiturn)</li> </ul>
Default setting	50kbit/s, node number 1

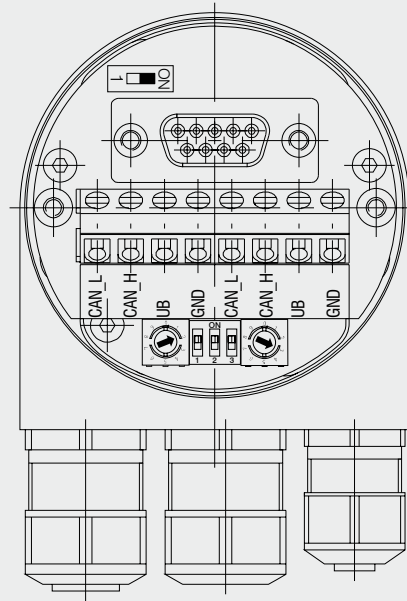

Setting of terminating Resistor for CANopen



ON = Last user  
OFF = User X

## Setting CANopen baud rate

Baud rate	Setting Dip Switch		
	1	2	3
10kBit/s	OFF	OFF	OFF
20kBit/s	OFF	OFF	ON
50kBit/s	OFF	ON	OFF
125kBit/s	OFF	ON	ON
250kBit/s	ON	OFF	OFF
500kBit/s	ON	OFF	ON
800kBit/s	ON	ON	OFF
1MBit/s	ON	ON	ON

## Contact description CANopen

CAN_L	CAN Bus Signal (dominant Low)
CAN_H	CAN Bus Signal (dominant High)
UB	Versorgungsspannung 10...30VDC
GND	Ground contact for UB

(Terminals with the same designation are internally interconnected)

## Settings of user address for CANopen

Address can be set with rotary switch. Example: User address 23

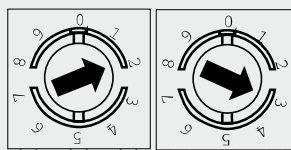

## Output specifications Profibus

### Profibus-DP features

Bus protocol	Profibus-DP
Profibus features	Device Class 1 and 2
Data exch. functions	Input: Position value Additional parameterized speed signal (readout of the current rotary speed) Output: Preset value
Preset value	With the "Preset" parameter the encoder can be set to a desired actual value that corresponds to the defined axis position of the system.
Parameter functions	Rotating direction: With the operating parameter the rotating direction for which the output code is to increase or decrease can be parameterized.
Diagnose	The encoder supports the following error messages: - Position error - Lithium cell voltage at lower limit (Multiturn)
Default setting	User address 00

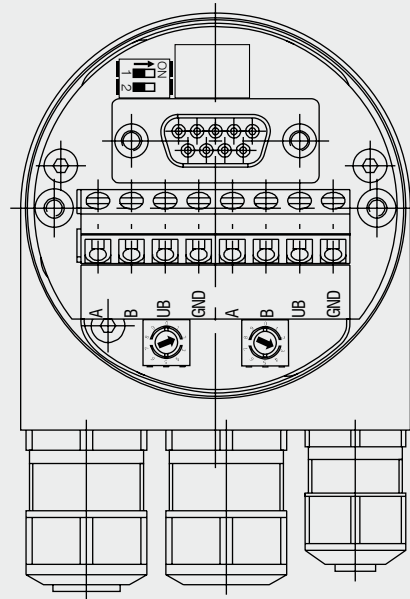

Settings of terminating resistors for Profibus-DP



ON = last user  
OFF = user X

### Settings of user address for Profibus-DP

Address can be set with rotary switch. Example: User address 23

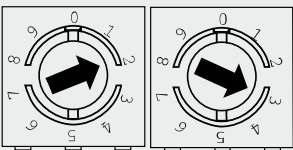

### Contact description Profibus-DP

A	A negative serial data line
B	Positive serial data line
UB	Supply voltage 10...30VDC
GND	Ground contact for UB

(Terminals with the same designation are internally interconnected)

## Signal output

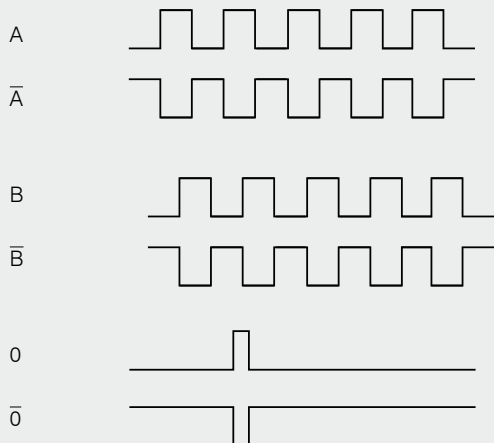

Output TTL	Linedriver (5VDC)
Level High	$\geq 2.5V$ (with $I = -20mA$ )
Level Low	$\leq 0.5V$ (with $I = 20mA$ )
Load High	$\leq 20mA$
Output	A, $\bar{A}$ , B, $\bar{B}$ , O

Output HTL	Push-pull (10 ... 30VDC)
Level High	$\geq UB -3V$ (with $I = -20mA$ )
Level Low	$\leq 1.5V$ (with $I = 20mA$ )
Load High	$\leq 40mA$
Output	A, $\bar{A}$ , B, $\bar{B}$ , O

Output E	Push-pull (5VDC)
Level High	UB -2.5V
Level Low	$\leq 0.5V$
Load High	$\leq 50mA$
Output	A, B, O

Output E830	Push-pull (8 ... 30VDC)
Level High	UB -3V
Level Low	$\leq 2.5V$
Load High	$\leq 50mA$
Output	A, B, O

## Pin assignment TTL, HTL

Pin	Cable color	Assignment
1	pink	B inv.
2	blue	UB Sense
3	red	N (Nullimpulses)
4	black	N inv. (Nullimpulses inv.)
5	brown	A
6	green	A inv.
7	-	-
8	grey	B
9	-	-
10	white/green	GND
11	white	GND Sense
12	brown/green	UB

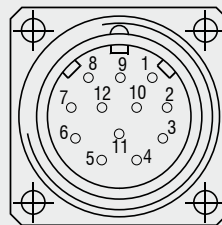

Pin 2 and Pin 12 are internally connected as well as Pin 11 and 10.  
For cable length >10m twisted pair wires are required.

## Connection assignment E, E830

Pin	Cable color	Assignment
-	white	0V
-	brown	+UB
-	green	A
-	-	$\bar{A}$
-	yellow	B
-	-	$\bar{B}$
-	grey	O

## High performance sensors made by Micro-Epsilon



### Sensors and systems for displacement, position and dimension

Eddy current displacement sensors  
Optical and laser sensors  
Capactive sensors  
Linear inductive sensors  
Draw wire displacement sensors  
Laser micrometer  
2D/3D profile sensors (laser scanner)  
Image processing



### Sensors and systems for non-contact temperature measurement

IR handheld  
Stationary IR sensors  
Thermal imager



### Turn key systems for quality inspection

of plastics and film  
of tires and rubber  
of endless band material  
of automotive components  
of glass



#### MICRO-EPSILON Headquarters

Koenigbacher Str. 15 · 94496 Ortenburg / Germany  
Tel. +49 (0) 8542 / 168-0 · Fax +49 (0) 8542 / 168-90  
info@micro-epsilon.com · www.micro-epsilon.com

#### MICRO-EPSILON UK Ltd.

Unit 1 Pioneer Business Park · Ellesmere Port · CH65 1AD  
Phone +44 (0) 151 355 6070  
info@micro-epsilon.co.uk · www.micro-epsilon.co.uk

#### MICRO-EPSILON USA

8120 Brownleigh Dr. · Raleigh, NC 27617 / USA  
Phone +1/919/787-9707 · Fax +1/919/787-9706  
info@micro-epsilon.us · www.me-sensor.com