

IEC Appliance Inlet C8, insert Mounting, Solder, PCB or Quick-connect Terminal



C8

70 °C



Description

- Drop-in type
- Appliance Inlet, Pin temperature 70 °C, Protection class II
- Solder, Quick Connect or PCB Terminal

Approvals

- VDE Certificate Number: 40002274
- UL File Number: E96454
- CSA File Number: 27324

Characteristics

- Contact pins are turned from solid material

References

We recommend for new applications the type [0720-FP](#)

Weblinks

[pdf-datasheet](#), [html-datasheet](#), [General Product Information](#), [RoHS](#), [CHINA-RoHS](#), [REACH](#), [Distributor-Stock-Check](#), [Accessories](#), [Detailed request for product](#)

Technical Data

Ratings IEC	2.5 A / 250 VAC; 50 Hz
Ratings UL/CSA	2.5 A / 250 VAC; 60 Hz
Dielectric Strength	> 4 kVAC between L-N > 2 kVAC between L/N-PE (1 min/50 Hz)
Allowable Operation Temp.	-25 °C to 70 °C
Degree of Protection	from front side IP 20 acc. to IEC 60529
Protection Class	Suitable for appliances with protection class II acc. to IEC 61140
Terminal	Solder, Quick Connect or PCB Terminal straight
Material: Housing	PA6, black / grey / white, UL 94V-0

Appliance Inlet	C8 acc. to IEC 60320-1 UL 498, CSA C22.2 no. 42 (for cold conditions) pin-temperature 70 °C, 2.5 A, Protection Class II
-----------------	--

Dimensions

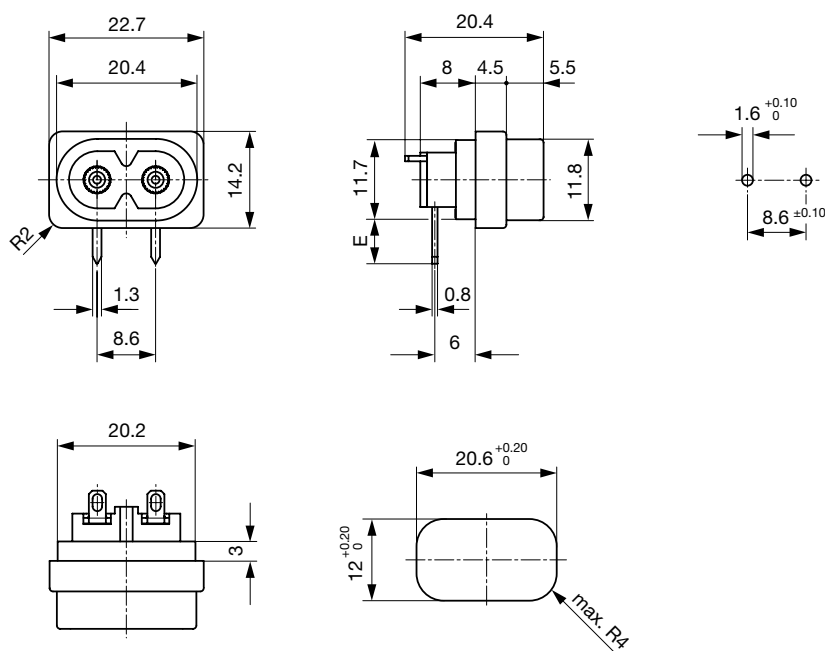

- E = PCB terminal standard (additional solder): 6.8 mm
- E = PCB terminal short (additional solder): 0.6 mm
- E = PCB terminal long (additional solder): 15.8 mm
- E = PCB terminal standard: 6.5 mm
- E = PCB terminal short: 5.0 mm
- E = PCB terminal long: 7.6 mm

Quick connect or solder terminal in orientation A (horizontal) or B (vertical)

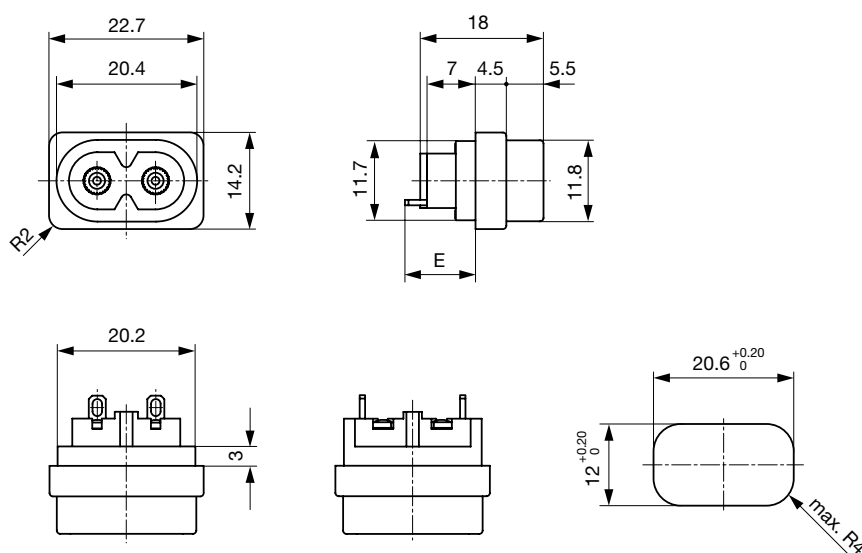

- E = Solder terminal short: 10.5 mm
- E = Solder terminal long: 14.2 mm
- E = Quick-connect terminal 2.8x0.8 mm: 16.5 mm
- E = Quick-connect terminal 4.8x0.8 mm: 15.0 mm (only orientation B)

Config. Code











2572 - H - A B C 0 - D - E G F

The characters are placeholders for the correspondingly keys of selections from the key tables.

2572 - H - A B C 0 - D - E G F = Type

Type	Configuration key
protection class II	X

2572 - H - A B C 0 - D - E G F = Terminals

Terminal L	Configuration key
short solder terminal (L = 4.8 mm) 	2
long solder terminal (L = 8.5 mm) 	3
PCB-terminal standard (additional solder terminal) 	4
PCB-terminal short (additional solder terminal) 	5
PCB-terminal long (additional solder terminal) 	6
Blade terminal (2.8 x 0.8 mm) 	7
Blade terminal (4.8 x 0.8 mm) 	8
PCB-terminal (standard) 	A
PCB-terminal (short) 	B
PCB-terminal (long) 	C

2572 - H - A B C 0 - D - E G F = Terminals

Terminal N	Configuration key
short solder terminal (L = 4.8 mm)	2
long solder terminal (L = 8.5 mm)	3
PCB-terminal standard (additional solder terminal)	4

Symbols similar as in table A

Terminal N	Configuration key
PCB-terminal short (additional solder terminal)	5
PCB-terminal long (additional solder terminal)	6
Blade terminal (2.8 x 0.8 mm)	7
Blade terminal (4.8 x 0.8 mm)	8
PCB-terminal (standard)	A
PCB-terminal (short)	B
PCB-terminal (long)	C

Symbols similar as in table A

2572 - H - A B C 0 - D - E G F = Terminals

Terminal Ground	Configuration key
without terminal	0

Symbols similar as in table A

2572 - H - A B C 0 - D - E G F = Color

Color	Configuration key
Black	A
Grey	B
White	D

2572 - H - A B C 0 - D - E G F = Style

Style	Configuration key
insert type	5

2572 - H - A B C 0 - D - E G F = Mass S

Mass "s"	Configuration key
00	

The dimension "S" is displayed in ($1/10$ mm). This information is also valid for the order code

2572 - H - A B C 0 - D - E G F = Orientation of Terminals

Orientation of Terminals	Configuration key
horizontal	A
vertical	B