

## NTC Thermistors, Radial Leaded, Standard Precision

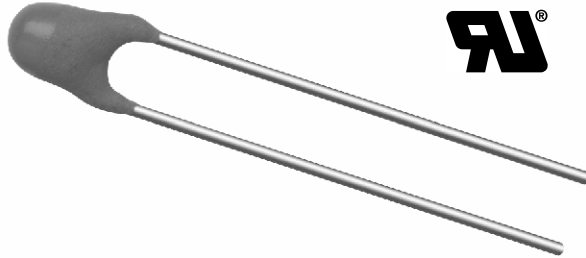

### FEATURES

- Accuracy over a wide temperature range
- High stability over a long life
- Excellent price/performance ratio
- UL recognized, file E148885
- Old part number was 2322 640 3/4/6....
- Component in accordance to RoHS 2002/95/EC and WEEE 2002/96/EC



**RoHS**  
COMPLIANT

### APPLICATIONS

- Temperature measurement, sensing and control, temperature compensation in industrial and consumer electronics

### DESCRIPTION

These thermistors have a negative temperature coefficient. The device consists of a chip with two solid copper tin plated leads. It is grey lacquered and color coded, but not insulated.

### PACKAGING

The thermistors are packed in bulk or tape on reel; see code numbers and relevant packaging quantities.

### DESIGN-IN SUPPORT

For complete Curve Computation, visit:  
[www.vishay.com/thermistors/curve-computation-list/](http://www.vishay.com/thermistors/curve-computation-list/)

### MARKING

The thermistors are marked with colored bands; see dimensions drawing and "Electrical data and ordering information".

### MOUNTING

By soldering in any position.  
Not intended for potted applications.

QUICK REFERENCE DATA	
PARAMETER	VALUE
Resistance value at 25 °C	3.3 Ω to 470 kΩ
Tolerance on $R_{25}$ - value	± 2 %; ± 3 %; ± 5 %
$B_{25/85}$ - value	2880K to 4570K
Tolerance on $B_{25/85}$ - value	± 0.5 % to ± 3 %
Maximum dissipation	500 mW
Dissipation factor $\delta$ (for information only)	7 mW/K 8.5 mW/K (for $R_{25}$ value ≤ 680 Ω)
Response time (in oil)	≈ 1.2 s
Thermal time constant $\tau$ (for information only)	15 s
Operating temperature range:	
at zero dissipation; continuously	- 40 °C to + 125 °C
at zero dissipation; for short periods	≤ 150 °C
at maximum dissipation	0 °C to 55 °C
Climatic category acc. IEC 60068-1	40/125/56
Weight	≈ 0.3 g

ELECTRICAL DATA AND ORDERING INFORMATION								
$R_{25}$ [Ω]	$B_{25/85}$ - VALUE		UL APPROVED [Y/N]	12NC 2381 640 3/4/6.... <sup>(1)</sup>	SAP MATERIAL AND ORDERING NO. NTCLE100E3....B0/T1/T2 <sup>(2)</sup>	COLOR CODE <sup>(3)</sup>		
	[K]	[± %]				I	II	III
3.3	2880	3	N	*338	338*B0	Orange	Orange	Gold
4.7	2880	3	N	*478	478*B0	Yellow	Violet	Gold
6.8	2880	3	N	*688	688*B0	Blue	Grey	Gold
10	2990	3	N	*109	109*B0	Brown	Black	Black
15	3041	3	N	*159	159*B0	Brown	Green	Black
22	3136	3	N	*229	229*B0	Red	Red	Black
33	3390	3	Y	*339	339*B0	Orange	Orange	Black
47	3390	3	Y	*479	479*B0	Yellow	Violet	Black
68	3390	3	Y	*689	689*B0	Blue	Grey	Black
100	3560	1.5	Y	*101	101*B0	Brown	Black	Brown
150	3560	1.5	Y	*151	151*B0	Brown	Green	Brown
220	3560	1.5	Y	*221	221*B0	Red	Red	Brown
330	3560	1.5	Y	*331	331*B0	Orange	Orange	Brown
470	3560	1.5	Y	*471	471*B0	Yellow	Violet	Brown

## ELECTRICAL DATA AND ORDERING INFORMATION

$R_{25}$ [Ω]	$B_{25/85}$ - VALUE		UL APPROVED [Y/N]	12NC 2381 640 3/4/6.... <sup>(1)</sup>	SAP MATERIAL AND ORDERING NO. NTCLE100E3...B0/T1/T2 <sup>(2)</sup>	COLOR CODE <sup>(3)</sup>		
	[K]	[± %]				I	II	III
680	3560	1.5	Y	*681	681*B0	Blue	Grey	Brown
1000	3528	0.5	Y	*102	102*B0	Brown	Black	Red
1500	3528	0.5	Y	*152	152*B0	Brown	Green	Red
2000	3528	0.5	Y	*202	202*B0	Red	Black	Red
2200	3977	0.75	Y	*222	222*B0	Red	Red	Red
2700	3977	0.75	Y	*272	272*B0	Red	violet	Red
3300	3977	0.75	Y	*332	332*B0	Orange	Orange	Red
4700	3977	0.75	Y	*472	472*B0	Yellow	Black	Red
5000	3977	0.75	Y	*502	502*B0	Green	Black	Red
6800	3977	0.75	Y	*682	682*B0	Blue	Grey	Red
10 000	3977	0.75	Y	*103	103*B0	Brown	Black	Orange
12 000	3740	2	Y	*123	123*B0	Brown	Red	Orange
15 000	3740	2	Y	*153	153*B0	Brown	Green	Orange
22 000	3740	2	Y	*223	223*B0	Red	Red	Orange
33 000	4090	1.5	Y	*333	333*B0	Orange	Orange	Orange
47 000	4090	1.5	Y	*473	473*B0	Yellow	Violet	Orange
50 000	4190	1.5	Y	*503	503*B0	Green	Black	Orange
68 000	4190	1.5	Y	*683	683*B0	Blue	Grey	Orange
100 000	4190	1.5	Y	*104	104*B0	Brown	Black	Yellow
150 000	4370	2.5	Y	*154	154*B0	Brown	Green	Yellow
220 000	4370	2.5	Y	*224	224*B0	Red	Red	Yellow
330 000	4570	1.5	N	*334	334*B0	Orange	Orange	Yellow
470 000	4570	1.5	N	*474	474*B0	Yellow	Violet	Yellow

### Notes

- (1) Replace \* in 12NC by 3 for 5 %, 6 for 3 %, 4 for 2 %
- (2) Replace \* in SAP by J for 5 %, H for 3 %, G for 2 %
- (3) For  $R_{25} \pm 2\%$  band IV is red,  $\pm 3\%$  band IV is orange,  $\pm 5\%$  band IV is gold

### DIMENSIONS in millimeters

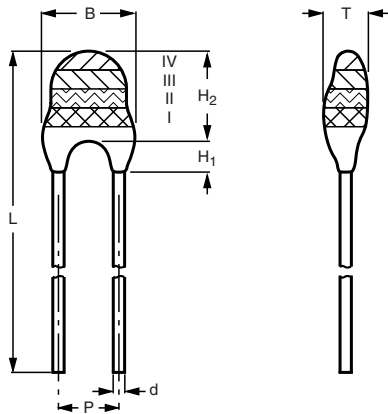

2381 640 6.338 to 6.474

### DERATING AND TEMPERATURE TOLERANCES

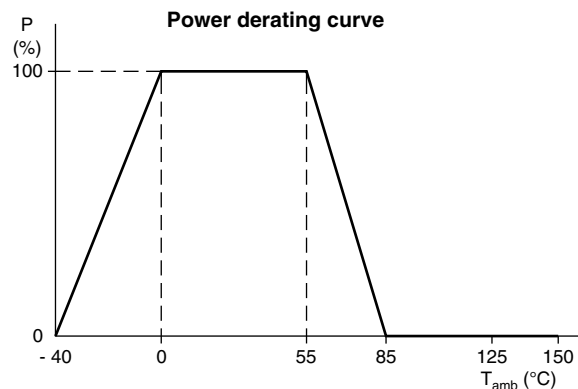

### PHYSICAL DIMENSIONS FOR RELEVANT TYPE (all dimensions in millimeters)

$R_{25}$ VALUE	$B_{max.}$	d	$H_1$		$H_2$ max.	L	P	$T_{max.}$
			Min.	Max.				
3.3 Ω to 220 Ω	5.0	0.6 ± 0.06	1.0	4.0	6.0	24 ± 1.5	2.54	4.0
330 Ω to 470 kΩ	3.3 ± 0.5	0.6 ± 0.06	1.0	3.0	6.0	24 ± 1.5	2.54	3.0



# NTCLE100E3...B0/T1/T2/2381 640 3/4/6....

NTC Thermistors, Radial Leaded,  
Standard Precision

Vishay BCcomponents

## TEMPERATURE DEVIATION AS A FUNCTION OF THE AMBIENT TEMPERATURE

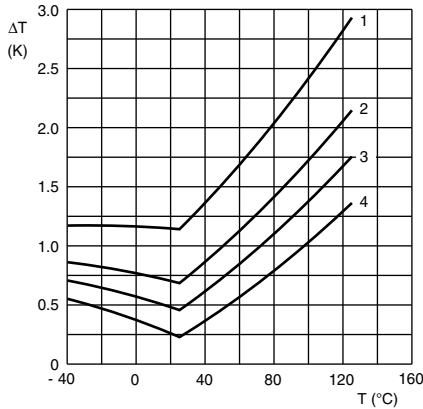

Curves valid for 2.2 to 10 kΩ  
 Curve 1:  $\Delta R_{25}/R_{25} = 5\%$   
 Curve 2:  $\Delta R_{25}/R_{25} = 3\%$   
 Curve 3:  $\Delta R_{25}/R_{25} = 2\%$   
 Curve 4:  $\Delta R_{25}/R_{25} = 1\%$   
 (for 2381 640 5.... series only)

## TEMPERATURE DEVIATION AS A FUNCTION OF THE AMBIENT TEMPERATURE

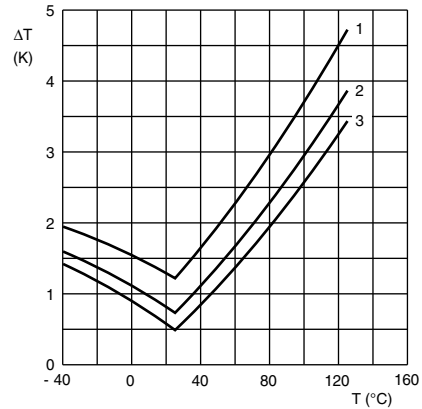

Curves valid for 12 to 22 kΩ  
 Curve 1:  $\Delta R_{25}/R_{25} = 5\%$   
 Curve 2:  $\Delta R_{25}/R_{25} = 3\%$   
 Curve 3:  $\Delta R_{25}/R_{25} = 2\%$

## TEMPERATURE DEVIATION AS A FUNCTION OF THE AMBIENT TEMPERATURE

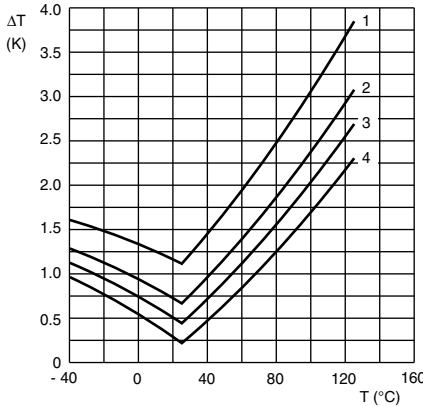

Curves valid for 33 to 47 kΩ  
 Curve 1:  $\Delta R_{25}/R_{25} = 5\%$   
 Curve 2:  $\Delta R_{25}/R_{25} = 3\%$   
 Curve 3:  $\Delta R_{25}/R_{25} = 2\%$   
 Curve 4:  $\Delta R_{25}/R_{25} = 1\%$   
 (for 2381 640 5.... series only)

## TEMPERATURE DEVIATION AS A FUNCTION OF THE AMBIENT TEMPERATURE

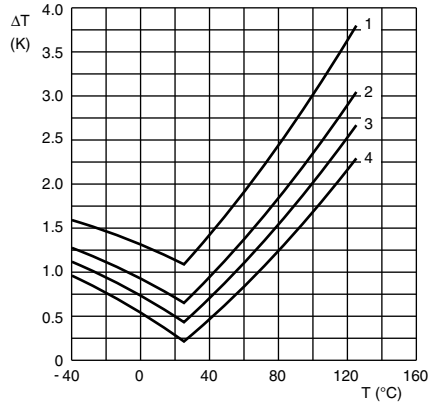

Curves valid for 68 to 100 kΩ  
 Curve 1:  $\Delta R_{25}/R_{25} = 5\%$   
 Curve 2:  $\Delta R_{25}/R_{25} = 3\%$   
 Curve 3:  $\Delta R_{25}/R_{25} = 2\%$   
 Curve 4:  $\Delta R_{25}/R_{25} = 1\%$   
 (for 2381 640 5.... series only)

## TEMPERATURE DEVIATION AS A FUNCTION OF THE AMBIENT TEMPERATURE

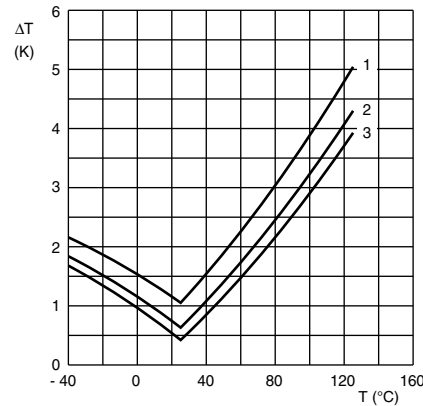

Curves valid for 150 to 220 kΩ  
 Curve 1:  $\Delta R_{25}/R_{25} = 5\%$   
 Curve 2:  $\Delta R_{25}/R_{25} = 3\%$   
 Curve 3:  $\Delta R_{25}/R_{25} = 2\%$

## TEMPERATURE DEVIATION AS A FUNCTION OF THE AMBIENT TEMPERATURE

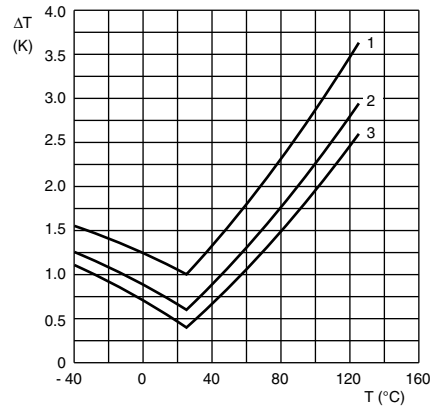

Curves valid for 330 to 470 kΩ  
 Curve 1:  $\Delta R_{25}/R_{25} = 5\%$   
 Curve 2:  $\Delta R_{25}/R_{25} = 3\%$   
 Curve 3:  $\Delta R_{25}/R_{25} = 2\%$



**R<sub>T</sub> VALUE AND TOLERANCE**

These thermistors have a narrow tolerance on the B-value, the result of which provides a very small tolerance on the nominal resistance value over a wide temperature range. For this reason the usual graphs of  $R = f(T)$  are replaced by Resistance Values at Intermediate Temperatures Tables, together with a formula to calculate the characteristics with a high precision.

**FORMULAE TO DETERMINE NOMINAL RESISTANCE VALUES**

The resistance values at intermediate temperatures, or the operating temperature values, can be calculated using the following interpolation laws (extended "Steinhart and Hart"):

$$R_{(T)} = R_{ref} \times e^{(A+B/T+C/T^2+D/T^3)} \quad (1)$$

$$T_{(R)} = \left( A_1 + B_1 \ln \frac{R}{R_{ref}} + C_1 \ln^2 \frac{R}{R_{ref}} + D_1 \ln^3 \frac{R}{R_{ref}} \right)^{-1} \quad (2)$$

where:

A, B, C, D, A<sub>1</sub>, B<sub>1</sub>, C<sub>1</sub> and D<sub>1</sub> are constant values depending on the material concerned; see table below.

R<sub>ref</sub> is the resistance value at a reference temperature (in this event 25 °C).

T is the temperature in K.

Formulae numbered and are interchangeable with an error of max. 0.005 °C in the range 25 °C to 125 °C and max. 0.015 °C in the range - 40 °C to + 25 °C.

**DETERMINATION OF THE RESISTANCE/TEMPERATURE DEVIATION FROM NOMINAL VALUE**

The total resistance deviation is obtained by combining the 'R<sub>25</sub>-tolerance' and the 'resistance deviation due to B-tolerance'.

When:

- X = R<sub>25</sub>-tolerance
- Y = resistance deviation due to B-tolerance
- Z = complete resistance deviation,

then:  $Z = \left[ \left( 1 + \frac{X}{100} \right) \times \left( 1 + \frac{Y}{100} \right) - 1 \right] \times 100 \%$  or  $Z \approx X + Y$

When:

- TCR = temperature coefficient
- ΔT = temperature deviation,

then:  $\Delta T = \frac{Z}{TCR}$

The temperature tolerances are plotted in the graphs on the previous page.

**Example:** at 0 °C, assume X = 5 %, Y = 0.89 % and TCR = 5.08 %/K (see Table ), then:

$$Z = \left\{ \left[ 1 + \frac{5}{100} \right] \times \left[ 1 + \frac{0.89}{100} \right] - 1 \right\} \times 100 \%$$

$$= \{ 1.05 \times 1.0089 - 1 \} \times 100 \% = 5.9345 \% (\approx 5.93 \%)$$

$$\Delta T = \frac{Z}{TCR} = \frac{5.93}{5.08} = 1.167 \text{ } ^\circ\text{C} (\approx 1.17 \text{ } ^\circ\text{C})$$

A NTC with a R<sub>25</sub> - value of 10 kΩ has a value of 32.56 kΩ between - 1.17 and + 1.17 °C.

**PARAMETER FOR DETERMINING NOMINAL RESISTANCE VALUES**

NUMBER	B <sub>25/R25</sub> (K)	NAME	TOL. B VALUE %	A	B (K)	C (K <sup>2</sup> )	D (K <sup>3</sup> )	A <sub>1</sub>	B <sub>1</sub> (K <sup>-1</sup> )	C <sub>1</sub> (K <sup>-2</sup> )	D <sub>1</sub> (K <sup>-3</sup> )
1	2880	Mat O. with Bn = 2880K	3	- 9.094	2251.74	229098	- 2.744820E+07	3.354016E-03	3.495020E-04	2.095959E-06	4.260615E-07
2	2990	Mat P. with Bn = 3990K	3	- 10.2296	2887.62	132336	- 2.502510E+07	3.354016E-03	3.415560E-04	4.955455E-06	4.364236E-07
3	3041	Mat Q. with Bn = 3041K	3	- 11.1334	3658.73	- 102895	5.166520E+05	3.354016E-03	3.349290E-04	3.683843E-06	7.050455E-07
4	3136	Mat R. with Bn = 3136K	3	- 12.4493	4702.74	- 402687	3.196830E+07	3.354016E-03	3.243880E-04	2.658012E-06	- 2.701560E-07
5	3390	Mat S. with Bn = 3390K	3	- 12.6814	4391.97	- 232807	1.509643E+07	3.354016E-03	2.993410E-04	2.135133E-06	- 5.672000E-09
6	3528 <sup>(1)</sup>	Mat I. with Bn = 3528K	0.5	- 12.0596	3687.667	- 7617.13	- 5.914730E+06	3.354016E-03	2.909670E-04	1.632136E-06	7.192200E-08
	3528 <sup>(2)</sup>			- 21.0704	11903.95	- 2504699	2.470338E+08	3.354016E-03	2.933908E-04	3.494314E-06	- 7.712690E-07
7	3560	Mat H. with Bn = 3560K	1.5	- 13.0723	4190.574	- 47158.4	- 1.199256E+07	3.354016E-03	2.884193E-04	4.118032E-06	1.786790E-07
8	3740	Mat B. with Bn = 3740K	2	- 13.8973	4557.725	- 98275	- 7.522357E+06	3.354016E-03	2.744032E-04	3.666944E-06	1.375492E-07
9	3977	Mat A. with Bn = 3977K	0.75	- 14.6337	4791.842	- 115334	- 3.730535E+06	3.354016E-03	2.569850E-04	2.620131E-06	6.383091E-08
10	4090	Mat C. with Bn = 4090K	1.5	- 15.5322	5229.973	- 160451	- 5.414091E+06	3.354016E-03	2.519107E-04	3.510939E-06	1.105179E-07
11	4190	Mat D. with Bn = 4190K	1.5	- 16.0349	5459.339	- 191141	- 3.328322E+06	3.354016E-03	2.460382E-04	3.405377E-06	1.034240E-07
12	4370	Mat E. with Bn = 4370K	2.5	- 16.8717	5759.15	- 194267	- 6.869149E+06	3.354016E-03	2.367720E-04	3.585140E-06	1.255349E-07
13	4570	Mat F. with Bn = 4570K	1.5	- 17.6439	6022.726	- 203157	- 7.183526E+06	3.354016E-03	2.264097E-04	3.278184E-06	1.097628E-07

**Notes**

- <sup>(1)</sup> Temperature < 25 °C
- <sup>(2)</sup> Temperature ≥ 25 °C



# NTCLE100E3...B0/T1/T2/2381 640 3/4/6....

NTC Thermistors, Radial Leaded, Vishay BCcomponents  
Standard Precision

For complete Curve Computation, visit: [www.vishay.com/thermistors/curve-computation-list/](http://www.vishay.com/thermistors/curve-computation-list/)

<b>RESISTANCE VALUES AT INTERMEDIATE TEMPERATURES WITH <math>R_{25}</math> AT 3.3, 4.7 AND 6.8 <math>\Omega</math></b>					
$T_{oper}$ [°C]	PART NUMBER NTCLE100E3338*** 2381 640 **338	PART NUMBER NTCLE100E3478*** 2381 640 **478	PART NUMBER NTCLE100E3688*** 2381 640 **688	TCR [%/K]	$\Delta R/R$ DUE TO $B_{tol.}$ [%]
	$R_T$ [ $\Omega$ ]	$R_T$ [ $\Omega$ ]	$R_T$ [ $\Omega$ ]		
- 40	45.00	64.09	92.73	- 4.97	8.08
- 35	35.25	50.20	72.63	- 4.80	7.30
- 30	27.84	39.64	57.36	- 4.64	6.55
- 25	22.16	31.56	45.66	- 4.48	5.84
- 20	17.78	25.32	36.63	- 4.33	5.15
- 15	14.37	20.46	29.60	- 4.19	4.49
- 10	11.69	16.65	24.09	- 4.05	3.85
- 5	9.582	13.65	19.74	- 3.92	3.24
0	7.904	11.26	16.29	- 3.79	2.65
5	6.560	9.344	13.52	- 3.66	2.08
10	5.479	7.803	11.29	- 3.55	1.54
15	4.602	6.554	9.482	- 3.43	1.01
20	3.886	5.535	8.008	- 3.32	0.49
25	3.300	4.700	6.800	- 3.22	0.00
30	2.816	4.011	5.803	- 3.12	0.48
35	2.415	3.440	4.977	- 3.02	0.94
40	2.081	2.964	4.289	- 2.93	1.39
45	1.801	2.566	3.712	- 2.84	1.82
50	1.566	2.230	3.227	- 2.76	2.24
55	1.367	1.947	2.817	- 2.68	2.65
60	1.198	1.706	2.469	- 2.60	3.04
65	1.054	1.501	2.172	- 2.52	3.43
70	0.9308	1.326	1.918	- 2.45	3.80
75	0.8248	1.175	1.700	- 2.38	4.16
80	0.7334	1.044	1.511	- 2.32	4.51
85	0.6542	0.9318	1.348	- 2.25	4.85
90	0.5854	0.8338	1.206	- 2.19	5.19
95	0.5255	0.7484	1.083	- 2.13	5.51
100	0.4730	0.6737	0.9748	- 2.07	5.82
105	0.4270	0.6082	0.8799	- 2.02	6.13
110	0.3865	0.5505	0.7965	- 1.97	6.43
115	0.3508	0.4996	0.7228	- 1.92	6.72
120	0.3192	0.4545	0.6576	- 1.87	7.00
125	0.2911	0.4145	0.5998	- 1.82	7.28
130	0.2661	0.3789	0.5483	- 1.77	7.55
135	0.2438	0.3472	0.5023	- 1.73	7.81
140	0.2238	0.3188	0.4612	- 1.69	8.07
145	0.2059	0.2933	0.4244	- 1.65	8.32
150	0.1899	0.2704	0.3912	- 1.61	8.56

# NTCLE100E3...B0/T1/T2/2381 640 3/4/6....



Vishay BCcomponents NTC Thermistors, Radial Leaded,  
Standard Precision

For complete Curve Computation, visit: [www.vishay.com/thermistors/curve-computation-list/](http://www.vishay.com/thermistors/curve-computation-list/)

<b>RESISTANCE VALUES AT INTERMEDIATE TEMPERATURES WITH R<sub>25</sub> AT 10, 15 AND 22 Ω</b>									
T <sub>oper</sub> [°C]	PART NUMBER NTCLE100E3109*** 2381 640 **109			PART NUMBER NTCLE100E3159*** 2381 640 **159			PART NUMBER NTCLE100E3229*** 2381 640 **229		
	R <sub>T</sub> [Ω]	TCR [%/K]	ΔR/R DUE TO B <sub>tol.</sub> [%]	R <sub>T</sub> [Ω]	TCR [%/K]	ΔR/R DUE TO B <sub>tol.</sub> [%]	R <sub>T</sub> [Ω]	TCR [%/K]	ΔR/R DUE TO B <sub>tol.</sub> [%]
-40	136.7	-4.86	8.39	224.8	-5.16	8.65	374.9	-5.54	8.80
-35	107.6	-4.72	7.58	174.5	-4.98	7.79	285.8	-5.31	7.95
-30	85.32	-4.58	6.81	136.6	-4.80	6.98	220.4	-5.10	7.14
-25	68.10	-4.44	6.06	107.9	-4.64	6.21	171.7	-4.90	6.36
-20	54.72	-4.31	5.35	85.94	-4.48	5.47	135.0	-4.71	5.61
-15	44.25	-4.18	4.66	68.96	-4.33	4.76	107.2	-4.53	4.89
-10	36.02	-4.06	4.00	55.74	-4.19	4.08	85.79	-4.37	4.20
-5	29.49	-3.94	3.37	45.37	-4.05	3.43	69.21	-4.22	3.53
0	24.30	-3.82	2.75	37.17	-3.92	2.81	56.26	-4.07	2.89
5	20.13	-3.71	2.16	30.65	-3.80	2.20	46.05	-3.94	2.27
10	16.77	-3.60	1.59	25.42	-3.68	1.62	37.94	-3.81	1.67
15	14.04	-3.50	1.04	21.21	-3.57	1.06	31.45	-3.69	1.10
20	11.82	-3.39	0.51	17.79	-3.46	0.52	26.23	-3.57	0.54
25	10.00	-3.30	0.00	15.00	-3.36	0.00	22.00	-3.47	0.00
30	8.500	-3.20	0.50	12.76	-3.26	0.49	18.55	-3.36	0.52
35	7.259	-3.11	0.98	10.86	-3.17	0.98	15.72	-3.26	1.02
40	6.226	-3.03	1.44	9.291	-3.08	1.46	13.38	-3.17	1.51
45	5.363	-2.94	1.89	7.982	-2.99	1.92	11.45	-3.08	1.98
50	4.639	-2.86	2.33	6.887	-2.91	2.36	9.833	-3.00	2.44
55	4.029	-2.78	2.75	5.966	-2.83	2.79	8.482	-2.92	2.88
60	3.512	-2.71	3.16	5.189	-2.75	3.21	7.346	-2.84	3.32
65	3.073	-2.64	3.56	4.529	-2.68	3.62	6.386	-2.76	3.73
70	2.698	-2.57	3.95	3.968	-2.61	4.02	5.572	-2.69	4.14
75	2.377	-2.50	4.32	3.488	-2.54	4.41	4.879	-2.62	4.53
80	2.101	-2.43	4.69	3.077	-2.48	4.78	4.286	-2.56	4.91
85	1.864	-2.37	5.04	2.722	-2.41	5.15	3.777	-2.50	5.29
90	1.658	-2.31	5.38	2.416	-2.35	5.51	3.339	-2.44	5.65
95	1.479	-2.25	5.72	2.151	-2.30	5.85	2.960	-2.38	6.00
100	1.323	-2.20	6.05	1.920	-2.24	6.19	2.632	-2.32	6.34
105	1.187	-2.14	6.36	1.719	-2.19	6.53	2.347	-2.27	6.68
110	1.068	-2.09	6.67	1.543	-2.13	6.85	2.098	-2.22	7.00
115	0.9635	-2.04	6.98	1.389	-2.08	7.17	1.880	-2.17	7.32
120	0.8712	-1.99	7.27	1.253	-2.03	7.48	1.689	-2.12	7.62
125	0.7897	-1.94	7.56	1.133	-1.99	7.78	1.521	-2.07	7.93
130	0.7174	-1.90	7.84	1.027	-1.94	8.08	1.373	-2.03	8.22
135	0.6533	-1.85	8.11	0.9326	-1.90	8.37	1.242	-1.98	8.50
140	0.5961	-1.81	8.37	0.8490	-1.86	8.65	1.126	-1.94	8.78
145	0.5451	-1.77	8.63	0.7744	-1.82	8.93	1.023	-1.90	9.06
150	0.4995	-1.73	8.89	0.7079	-1.78	9.20	0.9309	-1.86	9.32



# NTCLE100E3...B0/T1/T2/2381 640 3/4/6....

NTC Thermistors, Radial Leaded, Vishay BCcomponents  
Standard Precision

For complete Curve Computation, visit: [www.vishay.com/thermistors/curve-computation-list/](http://www.vishay.com/thermistors/curve-computation-list/)

<b>RESISTANCE VALUES AT INTERMEDIATE TEMPERATURES WITH <math>R_{25}</math> AT 33, 47 AND 68 <math>\Omega</math></b>					
$T_{oper}$ [°C]	PART NUMBER NTCLE100E3339*** 2381 640 **339	PART NUMBER NTCLE100E3479*** 2381 640 **479	PART NUMBER NTCLE100E3689*** 2381 640 **689	TCR [%/K]	$\Delta R/R$ DUE TO $B_{tol.}$ [%]
	$R_T$ [ $\Omega$ ]	$R_T$ [ $\Omega$ ]	$R_T$ [ $\Omega$ ]		
- 40	707.0	1007	1457	- 5.94	9.30
- 35	528.5	752.7	1089	- 5.70	8.44
- 30	399.5	569.0	823.3	- 5.49	7.60
- 25	305.3	434.8	629.1	- 5.28	6.79
- 20	235.6	335.6	485.5	- 5.09	6.01
- 15	183.5	261.4	378.2	- 4.90	5.25
- 10	144.3	205.5	297.3	- 4.73	4.51
- 5	114.3	162.8	235.6	- 4.57	3.80
0	91.34	130.1	188.2	- 4.42	3.11
5	73.51	104.7	151.5	- 4.27	2.45
10	59.59	84.87	122.8	- 4.13	1.80
15	48.63	69.26	100.2	- 4.00	1.18
20	39.94	56.88	82.29	- 3.88	0.58
25	33.00	47.00	68.00	- 3.76	0.00
30	27.43	39.06	56.51	- 3.64	0.56
35	22.92	32.64	47.23	- 3.54	1.11
40	19.26	27.42	39.68	- 3.43	1.63
45	16.26	23.16	33.50	- 3.34	2.14
50	13.79	19.65	28.42	- 3.24	2.63
55	11.76	16.74	24.23	- 3.15	3.11
60	10.06	14.33	20.74	- 3.07	3.57
65	8.652	12.32	17.83	- 2.98	4.02
70	7.468	10.64	15.39	- 2.90	4.45
75	6.471	9.216	13.33	- 2.83	4.87
80	5.628	8.015	11.60	- 2.76	5.27
85	4.912	6.996	10.12	- 2.69	5.66
90	4.302	6.127	8.865	- 2.62	6.04
95	3.780	5.384	7.790	- 2.55	6.41
100	3.332	4.746	6.867	- 2.49	6.77
105	2.946	4.196	6.071	- 2.43	7.11
110	2.613	3.721	5.384	- 2.37	7.45
115	2.324	3.310	4.788	- 2.32	7.77
120	2.072	2.951	4.270	- 2.26	8.09
125	1.853	2.639	3.818	- 2.21	8.39
130	1.661	2.365	3.422	- 2.16	8.69
135	1.492	2.125	3.075	- 2.11	8.97
140	1.344	1.914	2.770	- 2.07	9.25
145	1.213	1.728	2.500	- 2.02	9.52
150	1.098	1.564	2.262	- 1.98	9.79

# NTCLE100E3...B0/T1/T2/2381 640 3/4/6....



Vishay BCcomponents NTC Thermistors, Radial Leaded,  
Standard Precision

For complete Curve Computation, visit: [www.vishay.com/thermistors/curve-computation-list/](http://www.vishay.com/thermistors/curve-computation-list/)

RESISTANCE VALUES AT INTERMEDIATE TEMPERATURES WITH $R_{25}$ AT 100, 150, 220, 330, 470 AND 680 $\Omega$								
$T_{oper}$ [°C]	PART NUMBER NTCLE100E3101*** 2381 640 **101	PART NUMBER NTCLE100E3151*** 2381 640 **151	PART NUMBER NTCLE100E3221*** 2381 640 **221	PART NUMBER NTCLE100E3331*** 2381 640 **331	PART NUMBER NTCLE100E3471*** 2381 640 **471	PART NUMBER NTCLE100E3681*** 2381 640 **681	TCR [%/K]	$\Delta R/R$ TO $B_{tol}$ [%]
	$R_T$ [ $\Omega$ ]	$R_T$ [ $\Omega$ ]	$R_T$ [ $\Omega$ ]	$R_T$ [ $\Omega$ ]	$R_T$ [ $\Omega$ ]	$R_T$ [ $\Omega$ ]		
-40	2193	3289	4824	7236	10 305	14 910	-5.75	4.99
-35	1652	2478	3635	5452	7766	11 235	-5.57	4.51
-30	1256	1884	2763	4144	5902	8540	-5.40	4.05
-25	962.5	1444	2117	3176	4524	6545	-5.24	3.61
-20	743.6	1115	1636	2454	3495	5057	-5.08	3.19
-15	579.0	868.5	1274	1911	2721	3937	-4.93	2.78
-10	454.2	681.2	999.1	1499	2135	3088	-4.78	2.38
-5	358.8	538.2	789.4	1184	1686	2440	-4.64	2.01
0	285.4	428.2	628.0	942.0	1342	1941	-4.51	1.64
5	228.6	342.9	502.9	754.4	1074	1554	-4.38	1.29
10	184.2	276.4	405.3	608.0	866.0	1253	-4.25	0.95
15	149.4	224.1	328.7	493.1	702.2	1016	-4.13	0.62
20	121.9	182.8	268.2	402.2	572.9	828.8	-4.01	0.31
25	100.0	150.0	220.0	330.0	470.0	680.0	-3.90	0.00
30	82.49	123.7	181.5	272.2	387.7	561.0	-3.80	0.30
35	68.41	102.6	150.5	225.8	321.5	465.2	-3.69	0.58
40	57.02	85.54	125.5	188.2	268.0	387.8	-3.59	0.86
45	47.77	71.65	105.1	157.6	224.5	324.8	-3.50	1.13
50	40.20	60.30	88.44	132.7	188.9	273.3	-3.40	1.39
55	33.98	50.98	74.76	112.1	159.7	231.1	-3.31	1.64
60	28.86	43.28	63.48	95.23	135.6	196.2	-3.23	1.88
65	24.61	36.91	54.13	81.20	115.6	167.3	-3.15	2.12
70	21.07	31.60	46.35	69.52	99.01	143.3	-3.07	2.35
75	18.11	27.16	39.84	59.76	85.11	123.1	-2.99	2.57
80	15.62	23.43	34.37	51.56	73.43	106.2	-2.91	2.79
85	13.53	20.29	29.76	44.65	63.59	92.00	-2.84	3.00
90	11.76	17.63	25.86	38.80	55.26	79.95	-2.77	3.21
95	10.25	15.38	22.55	33.83	48.18	69.71	-2.71	3.41
100	8.968	13.45	19.73	29.59	42.15	60.98	-2.64	3.60
105	7.871	11.81	17.32	25.97	36.99	53.52	-2.58	3.79
110	6.928	10.39	15.24	22.86	32.56	47.11	-2.52	3.97
115	6.117	9.176	13.46	20.19	28.75	41.60	-2.46	4.15
120	5.416	8.125	11.92	17.87	25.46	36.83	-2.41	4.33
125	4.809	7.214	10.58	15.87	22.60	32.70	-2.35	4.50
130	4.282	6.422	9.419	14.13	20.12	29.11	-2.30	4.66
135	3.822	5.732	8.408	12.61	17.96	25.99	-2.25	4.83
140	3.420	5.130	7.523	11.29	16.07	23.25	-2.20	4.99
145	3.068	4.601	6.749	10.12	14.42	20.86	-2.15	5.14
150	2.758	4.137	6.068	9.102	12.96	18.76	-2.10	5.29



# NTCLE100E3...B0/T1/T2/2381 640 3/4/6....

NTC Thermistors, Radial Leaded, Vishay BCcomponents  
Standard Precision

For complete Curve Computation, visit: [www.vishay.com/thermistors/curve-computation-list/](http://www.vishay.com/thermistors/curve-computation-list/)

<b>RESISTANCE VALUES AT INTERMEDIATE TEMPERATURES WITH <math>R_{25}</math> AT 1, 1.5 AND 2 k<math>\Omega</math></b>					
$T_{oper}$ [°C]	PART NUMBER NTCLE100E3102*** 2381 640 **102	PART NUMBER NTCLE100E3152*** 2381 640 **152	PART NUMBER NTCLE100E3202*** 2381 640 **202	TCR [%/K]	$\Delta R/R$ DUE TO $B_{tol.}$ [%]
	$R_T$ [ $\Omega$ ]	$R_T$ [ $\Omega$ ]	$R_T$ [ $\Omega$ ]		
- 40	23 342	35 013	46 684	- 6.06	1.65
- 35	17 336	26 004	34 672	- 5.84	1.49
- 30	13 018	19 526	26 035	- 5.62	1.34
- 25	9877	14 816	19 754	- 5.42	1.19
- 20	7569	11 353	15 138	- 5.23	1.05
- 15	5855	8782	11 709	- 5.05	0.92
- 10	4569	6854	9138	- 4.87	0.79
- 5	3596	5395	7193	- 4.71	0.66
0	2854	4280	5707	- 4.55	0.54
5	2282	3422	4563	- 4.40	0.43
10	1838	2757	3675	- 4.26	0.31
15	1491	2236	2981	- 4.12	0.21
20	1217	1826	2434	- 3.99	0.10
25	1000	1500	2000	- 3.87	0.00
30	826.6	1240	1653	- 3.75	0.10
35	687.3	1031	1375	- 3.63	0.19
40	574.6	861.9	1149	- 3.53	0.28
45	482.7	724.0	965.4	- 3.42	0.37
50	407.4	611.0	814.7	- 3.32	0.46
55	345.2	517.8	690.5	- 3.23	0.54
60	293.7	440.6	587.4	- 3.14	0.62
65	250.8	376.2	501.6	- 3.05	0.70
70	214.9	322.4	429.8	- 2.97	0.78
75	184.7	277.1	369.5	- 2.89	0.86
80	159.3	238.9	318.6	- 2.81	0.93
85	137.7	206.6	275.5	- 2.73	1.01
90	119.4	179.1	238.8	- 2.66	1.08
95	103.8	155.7	207.6	- 2.59	1.15
100	90.45	135.7	180.9	- 2.53	1.22
105	79.00	118.5	158.0	- 2.46	1.29
110	69.15	103.7	138.3	- 2.40	1.35
115	60.66	90.99	121.3	- 2.34	1.42
120	53.32	79.98	106.6	- 2.29	1.48
125	46.96	70.44	93.92	- 2.23	1.55
130	41.43	62.15	82.87	- 2.18	1.61
135	36.63	54.94	73.25	- 2.13	1.67
140	32.43	48.65	64.87	- 2.08	1.73
145	28.77	43.16	57.54	- 2.03	1.79
150	25.56	38.34	51.12	- 1.98	1.85

# NTCLE100E3...B0/T1/T2/2381 640 3/4/6....



Vishay BCcomponents NTC Thermistors, Radial Leaded,  
Standard Precision

For complete Curve Computation, visit: [www.vishay.com/thermistors/curve-computation-list/](http://www.vishay.com/thermistors/curve-computation-list/)

<b>RESISTANCE VALUES AT INTERMEDIATE TEMPERATURES WITH <math>R_{25}</math> AT 2.2, 2.7, 3.3, 4.7, 5.0, 6.8 AND 10 k<math>\Omega</math></b>									
$T_{oper}$ [°C]	PART NUMBER NTCLE100E3222*** 2381 640 **222	PART NUMBER NTCLE100E3272*** 2381 640 **272	PART NUMBER NTCLE100E3332*** 2381 640 **332	PART NUMBER NTCLE100E3472*** 2381 640 **472	PART NUMBER NTCLE100E3502*** 2381 640 **502	PART NUMBER NTCLE100E3682*** 2381 640 **682	PART NUMBER NTCLE100E3103*** 2381 640 **103	TCR [%/K]	$\Delta R/R$ DU TO $B_{tol.}$ [%]
	$R_T$ [ $\Omega$ ]	$R_T$ [ $\Omega$ ]	$R_T$ [ $\Omega$ ]	$R_T$ [ $\Omega$ ]	$R_T$ [ $\Omega$ ]	$R_T$ [ $\Omega$ ]	$R_T$ [ $\Omega$ ]		
-40	73 061	89 665	109 591	156 084	166 047	225 824	332 094	-6.62	2.79
-35	52 778	64 773	79 167	112 753	119 950	163 132	239 900	-6.39	2.52
-30	38 544	47 304	57 816	82 344	87 600	119 136	175 200	-6.18	2.26
-25	28 443	34 907	42 665	60 765	64 643	87 915	129 287	-5.98	2.02
-20	21 199	26 017	31 798	45 288	48 179	65 524	96 358	-5.78	1.78
-15	15 950	19 575	23 925	34 075	36 250	49 300	72 500	-5.60	1.55
-10	12 110	14 862	18 165	25 872	27 523	37 431	55 046	-5.42	1.33
-5	9275	11 382	13 912	19 814	21 078	28 667	42 157	-5.25	1.12
0	7162	8790	10 743	15 300	16 277	22 137	32 554	-5.09	0.92
5	5574	6841	8362	11 909	12 669	17 230	25 339	-4.93	0.72
10	4372	5365	6558	9340	9936	13 513	19 872	-4.79	0.53
15	3454	4239	5180	7378	7849	10 675	15 698	-4.64	0.35
20	2747	3372	4121	5869	6244	8492	12 488	-4.51	0.17
25	2200	2700	3300	4700	5000	6800	10 000	-4.38	0.00
30	1773	2176	2659	3788	4030	5480	8059	-4.25	0.17
35	1438	1764	2156	3071	3267	4444	6535	-4.13	0.32
40	1173	1439	1759	2505	2665	3624	5330	-4.02	0.48
45	961.8	1180	1443	2055	2186	2973	4372	-3.91	0.63
50	793.2	973.4	1190	1694	1803	2452	3605	-3.80	0.77
55	657.5	806.9	986.3	1405	1494	2032	2989	-3.70	0.91
60	547.8	672.3	821.7	1170	1245	1693	2490	-3.60	1.05
65	458.6	562.8	687.9	979.7	1042	1417	2084	-3.51	1.18
70	385.7	473.3	578.5	823.9	876.5	1192	1753	-3.42	1.31
75	325.8	399.8	488.7	696.0	740.5	1007	1481	-3.33	1.44
80	276.4	339.2	414.6	590.5	628.2	854.3	1256	-3.25	1.56
85	235.5	289.0	353.2	503.0	535.2	727.8	1070	-3.17	1.68
90	201.4	247.2	302.1	430.2	457.7	622.5	915.4	-3.09	1.79
95	172.9	212.2	259.4	369.4	393.0	534.5	786.0	-3.01	1.90
100	149.0	182.9	223.5	318.3	338.6	460.6	677.3	-2.94	2.01
105	128.9	158.2	193.3	275.3	292.9	398.3	585.7	-2.87	2.12
110	111.8	137.2	167.7	238.9	254.2	345.7	508.3	-2.80	2.22
115	97.37	119.5	146.1	208.0	221.3	301.0	442.6	-2.74	2.32
120	85.05	104.4	127.6	181.7	193.3	262.9	386.6	-2.67	2.42
125	74.52	91.46	111.8	159.2	169.4	230.3	338.7	-2.61	2.51
130	65.49	80.38	98.24	139.9	148.8	202.4	297.7	-2.55	2.61
135	57.72	70.84	86.59	123.3	131.2	178.4	262.4	-2.50	2.70
140	51.02	62.62	76.53	109.0	116.0	157.7	231.9	-2.44	2.78
145	45.22	55.49	67.83	96.60	102.8	139.8	205.5	-2.39	2.87
150	40.18	49.31	60.27	85.84	91.32	124.2	182.6	-2.34	2.96



# NTCLE100E3...B0/T1/T2/2381 640 3/4/6....

NTC Thermistors, Radial Leaded, Vishay BCcomponents  
Standard Precision

For complete Curve Computation, visit: [www.vishay.com/thermistors/curve-computation-list/](http://www.vishay.com/thermistors/curve-computation-list/)

<b>RESISTANCE VALUES AT INTERMEDIATE TEMPERATURES WITH R<sub>25</sub> AT 12, 15 AND 22 kΩ</b>					
T <sub>oper</sub> [°C]	PART NUMBER NTCLE100E3123*** 2381 640 **123	PART NUMBER NTCLE100E3153*** 2381 640 **153	PART NUMBER NTCLE100E3223*** 2381 640 **223	TCR [%/K]	ΔR/R DUE TO B <sub>tol.</sub> [%]
	R <sub>T</sub> [kΩ]	R <sub>T</sub> [kΩ]	R <sub>T</sub> [kΩ]		
- 40	309.4	386.7	567.2	- 6.07	7.00
- 35	229.5	286.9	420.8	- 5.88	6.32
- 30	171.8	214.8	315.0	- 5.70	5.68
- 25	129.8	162.3	238.0	- 5.52	5.06
- 20	98.93	123.7	181.4	- 5.35	4.46
- 15	76.02	95.02	139.4	- 5.19	3.89
- 10	58.88	73.60	107.9	- 5.03	3.34
- 5	45.95	57.44	84.25	- 4.88	2.81
0	36.13	45.16	66.24	- 4.74	2.30
5	28.61	35.76	52.45	- 4.60	1.80
10	22.80	28.51	41.81	- 4.47	1.33
15	18.30	22.87	33.55	- 4.34	0.87
20	14.77	18.47	27.08	- 4.22	0.43
25	12.00	15.00	22.00	- 4.10	0.00
30	9.804	12.25	17.97	- 3.99	0.41
35	8.054	10.07	14.77	- 3.88	0.81
40	6.652	8.315	12.20	- 3.77	1.20
45	5.522	6.903	10.12	- 3.67	1.58
50	4.607	5.759	8.447	- 3.58	1.94
55	3.862	4.828	7.081	- 3.48	2.29
60	3.252	4.066	5.963	- 3.39	2.64
65	2.751	3.439	5.044	- 3.30	2.97
70	2.337	2.921	4.284	- 3.22	3.29
75	1.993	2.492	3.654	- 3.14	3.60
80	1.707	2.134	3.129	- 3.06	3.91
85	1.467	1.834	2.690	- 2.99	4.20
90	1.266	1.582	2.321	- 2.92	4.49
95	1.096	1.370	2.010	- 2.85	4.77
100	0.9524	1.190	1.746	- 2.78	5.04
105	0.8302	1.038	1.522	- 2.71	5.31
110	0.7260	0.9075	1.331	- 2.65	5.56
115	0.6369	0.7961	1.168	- 2.59	5.82
120	0.5604	0.7005	1.027	- 2.53	6.06
125	0.4945	0.6181	0.9065	- 2.47	6.30
130	0.4375	0.5469	0.8022	- 2.42	6.53
135	0.3882	0.4853	0.7117	- 2.37	6.76
140	0.3454	0.4317	0.6332	- 2.31	6.98
145	0.3080	0.3850	0.5647	- 2.26	7.20
150	0.2754	0.3442	0.5049	- 2.22	7.41

# NTCLE100E3...B0/T1/T2/2381 640 3/4/6....



Vishay BCcomponents NTC Thermistors, Radial Leaded,  
Standard Precision

For complete Curve Computation, visit: [www.vishay.com/thermistors/curve-computation-list/](http://www.vishay.com/thermistors/curve-computation-list/)

T <sub>oper</sub> [°C]	PART NUMBER NTCLE100E3 2381 640								
	333*** **333	473*** **473	TCR [%/K]	ΔR/R DUE TO B <sub>tol.</sub> [%]	503*** **503	683*** **683	104*** **104	TCR [%/K]	ΔR/R DUE TO B <sub>tol.</sub> [%]
	R <sub>T</sub> [kΩ]	R <sub>T</sub> [kΩ]			R <sub>T</sub> [kΩ]	R <sub>T</sub> [kΩ]	R <sub>T</sub> [kΩ]		
- 40	1116	1589	- 6.54	5.74	1833	2493	3666	- 6.69	5.88
- 35	808.6	1152	- 6.34	5.19	1319	1794	2638	- 6.49	5.31
- 30	591.7	842.8	- 6.15	4.66	958.3	1303	1917	- 6.29	4.77
- 25	437.1	622.6	- 5.96	4.15	703.1	956.2	1406	- 6.10	4.25
- 20	325.9	464.1	- 5.79	3.66	520.6	708.0	1041	- 5.92	3.75
- 15	245.0	349.0	- 5.62	3.19	388.9	528.9	777.8	- 5.75	3.27
- 10	185.8	264.6	- 5.45	2.74	293.0	398.5	586.1	- 5.58	2.80
- 5	142.0	202.3	- 5.30	2.30	222.6	302.8	445.3	- 5.42	2.36
0	109.4	155.8	- 5.14	1.88	170.5	231.8	340.9	- 5.26	1.93
5	84.91	120.9	- 5.00	1.48	131.5	178.9	263.1	- 5.11	1.52
10	66.37	94.53	- 4.86	1.09	102.2	139.0	204.4	- 4.97	1.12
15	52.24	74.40	- 4.72	0.71	80.01	108.8	160.0	- 4.83	0.73
20	41.39	58.95	- 4.59	0.35	63.04	85.74	126.1	- 4.70	0.36
25	33.00	47.00	- 4.47	0.00	50.00	68.00	100.0	- 4.57	0.00
30	26.47	37.71	- 4.35	0.34	39.90	54.27	79.81	- 4.45	0.35
35	21.37	30.43	- 4.23	0.67	32.04	43.57	64.08	- 4.33	0.68
40	17.34	24.70	- 4.12	0.99	25.87	35.19	51.75	- 4.22	1.01
45	14.15	20.15	- 4.01	1.29	21.01	28.57	42.02	- 4.11	1.33
50	11.61	16.53	- 3.91	1.59	17.15	23.33	34.31	- 4.00	1.63
55	9.572	13.63	- 3.81	1.88	14.08	19.15	28.16	- 3.90	1.93
60	7.931	11.30	- 3.71	2.16	11.61	15.79	23.22	- 3.80	2.21
65	6.603	9.404	- 3.62	2.43	9.623	13.09	19.25	- 3.71	2.49
70	5.522	7.865	- 3.53	2.70	8.012	10.90	16.02	- 3.62	2.76
75	4.639	6.607	- 3.44	2.95	6.701	9.114	13.40	- 3.53	3.03
80	3.913	5.573	- 3.36	3.20	5.629	7.655	11.26	- 3.45	3.28
85	3.315	4.721	- 3.28	3.45	4.748	6.457	9.496	- 3.36	3.53
90	2.819	4.015	- 3.20	3.68	4.021	5.469	8.042	- 3.28	3.77
95	2.406	3.427	- 3.13	3.91	3.419	4.649	6.837	- 3.21	4.01
100	2.062	2.936	- 3.05	4.13	2.918	3.968	5.835	- 3.13	4.24
105	1.773	2.525	- 2.98	4.35	2.499	3.399	4.998	- 3.06	4.46
110	1.530	2.179	- 2.92	4.56	2.148	2.921	4.296	- 2.99	4.68
115	1.324	1.886	- 2.85	4.77	1.853	2.519	3.705	- 2.93	4.89
120	1.150	1.638	- 2.79	4.97	1.603	2.180	3.206	- 2.86	5.09
125	1.002	1.427	- 2.73	5.17	1.392	1.892	2.783	- 2.80	5.29
130	0.8757	1.247	- 2.67	5.36	1.212	1.648	2.423	- 2.74	5.49
135	0.7675	1.093	- 2.61	5.54	1.058	1.439	2.116	- 2.68	5.68
140	0.6746	0.9608	- 2.55	5.73	0.9269	1.261	1.854	- 2.62	5.87
145	0.5946	0.8468	- 2.50	5.90	0.8141	1.107	1.628	- 2.57	6.05
150	0.5254	0.7483	- 2.45	6.08	0.7170	0.9752	1.434	- 2.51	6.23



# NTCLE100E3...B0/T1/T2/2381 640 3/4/6....

NTC Thermistors, Radial Leaded, Vishay BCcomponents  
Standard Precision

For complete Curve Computation, visit: [www.vishay.com/thermistors/curve-computation-list/](http://www.vishay.com/thermistors/curve-computation-list/)

<b>RESISTANCE VALUES AT INTERMEDIATE TEMPERATURES WITH R<sub>25</sub> AT 150, 220, 330 AND 470 kΩ</b>								
T <sub>oper</sub> [°C]	PART NUMBER NTCLE100E3 2381 640							
	154*** **154	224*** **224	TCR [%/K]	ΔR/R DUE TO B <sub>tol.</sub> [%]	334*** **334	474*** **474	TCR [%/K]	ΔR/R DUE TO B <sub>tol.</sub> [%]
	R <sub>T</sub> [kΩ]	R <sub>T</sub> [kΩ]			R <sub>T</sub> [kΩ]	R <sub>T</sub> [kΩ]		
- 40	6153	9024	- 6.83	10.22	16 044	22 850	- 7.14	6.41
- 35	4394	6444	- 6.64	9.24	11 282	16 068	- 6.94	5.80
- 30	3168	4646	- 6.45	8.29	8013	11 413	- 6.74	5.20
- 25	2305	3381	- 6.27	7.39	5747	8185	- 6.55	4.64
- 20	1693	2483	- 6.09	6.52	4161	5926	- 6.37	4.09
- 15	1254	1839	- 5.92	5.68	3040	4329	- 6.19	3.57
- 10	936.4	1373	- 5.75	4.88	2240	3190	- 6.02	3.06
- 5	705.0	1034	- 5.60	4.10	1665	2371	- 5.85	2.57
0	535.0	784.7	- 5.44	3.36	1248	1777	- 5.69	2.11
5	409.1	600.0	- 5.29	2.64	942.3	1342	- 5.54	1.65
10	315.1	462.1	- 5.15	1.94	717.1	1021	- 5.39	1.22
15	244.4	358.4	- 5.01	1.27	549.8	783.0	- 5.24	0.80
20	190.8	279.9	- 4.88	0.63	424.5	604.6	- 5.10	0.39
25	150.0	220.0	- 4.75	0.00	330.0	470.0	- 4.97	0.00
30	118.6	174.0	- 4.63	0.60	258.2	367.8	- 4.84	0.38
35	94.42	138.5	- 4.51	1.19	203.4	289.6	- 4.72	0.75
40	75.58	110.9	- 4.39	1.76	161.1	229.5	- 4.59	1.10
45	60.85	89.24	- 4.28	2.30	128.4	182.9	- 4.48	1.45
50	49.25	72.24	- 4.17	2.83	103.0	146.7	- 4.37	1.78
55	40.08	58.78	- 4.07	3.35	83.00	118.2	- 4.26	2.10
60	32.78	48.08	- 3.97	3.85	67.26	95.80	- 4.15	2.41
65	26.94	39.51	- 3.87	4.33	54.79	78.04	- 4.05	2.72
70	22.25	32.63	- 3.78	4.80	44.85	63.88	- 3.95	3.01
75	18.46	27.07	- 3.69	5.26	36.90	52.55	- 3.86	3.30
80	15.38	22.56	- 3.60	5.70	30.49	43.43	- 3.77	3.58
85	12.87	18.88	- 3.52	6.14	25.31	36.05	- 3.68	3.85
90	10.82	15.87	- 3.44	6.56	21.10	30.06	- 3.59	4.11
95	9.129	13.39	- 3.36	6.96	17.67	25.16	- 3.51	4.37
100	7.732	11.34	- 3.28	7.36	14.85	21.15	- 3.43	4.62
105	6.574	9.642	- 3.21	7.75	12.53	17.85	- 3.35	4.86
110	5.610	8.228	- 3.14	8.13	10.62	15.12	- 3.28	5.10
115	4.804	7.046	- 3.07	8.49	9.029	12.86	- 3.21	5.33
120	4.128	6.054	- 3.00	8.85	7.704	10.97	- 3.14	5.55
125	3.559	5.219	- 2.94	9.20	6.597	9.396	- 3.07	5.77
130	3.078	4.514	- 2.87	9.54	5.668	8.072	- 3.00	5.99
135	2.670	3.916	- 2.81	9.87	4.885	6.958	- 2.94	6.20
140	2.323	3.408	- 2.75	10.20	4.224	6.016	- 2.88	6.40
145	2.028	2.974	- 2.69	10.52	3.663	5.217	- 2.82	6.60
150	1.774	2.603	- 2.64	10.83	3.186	4.538	- 2.76	6.79

**PACKAGING**  
**TAPE SPECIFICATIONS**

Thermistors on tape

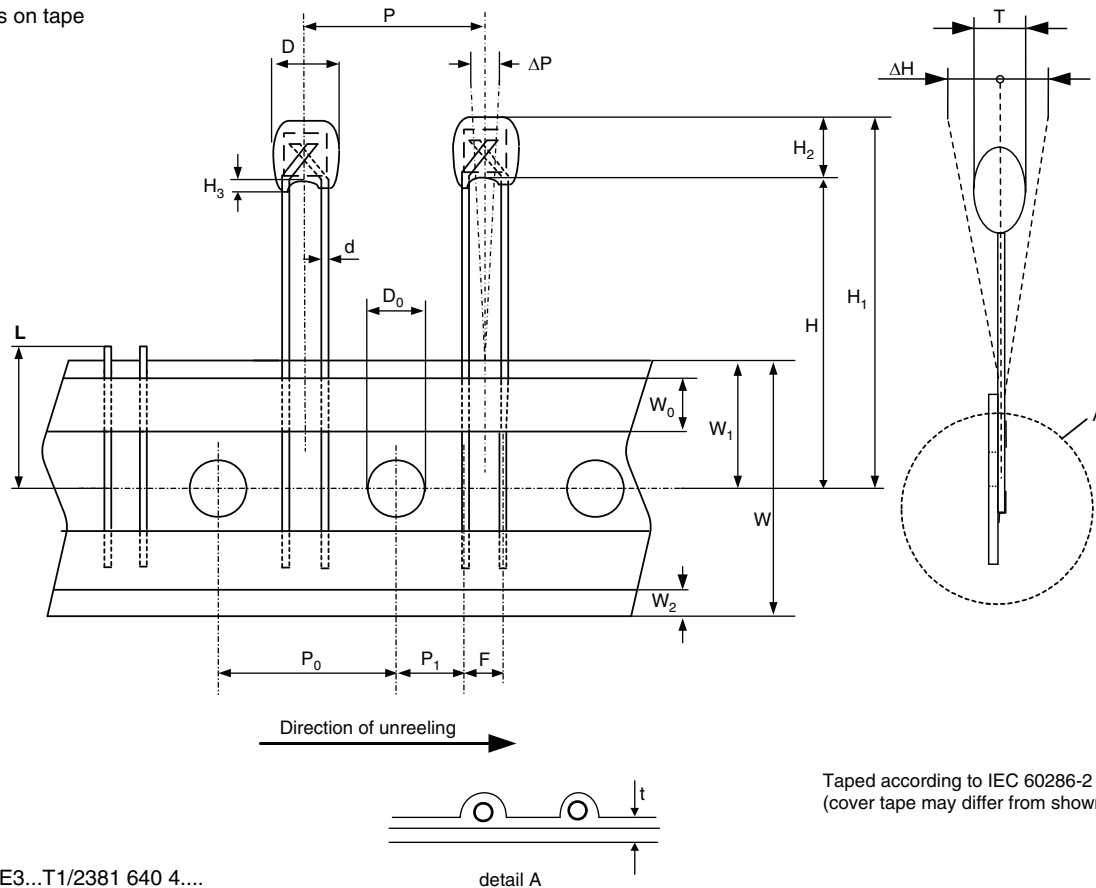

1E pitch  
NTCLE100E3...T1/2381 640 4...

DIMENSIONS in millimeters				
DETAILS	SYMBOL	DIMENSIONS NOMINAL	TOLERANCE	REMARKS
Body diameter	D	3.3	± 0.5	5 max. for 3.3 Ω to 220 Ω
Lead diameter	d	0.6	± 10 %	
Feed hole diameter	D <sub>0</sub>	4.0	± 0.2	
Lead to lead distance	F	2.54	± 0.3	Guaranteed between component and tape
Distance component to tape centre	H	22.0	± 1.0	
Component height	H <sub>1</sub>	32.2	max.	
Component alignment	Δh	0	± 2.0	
Distance top/bottom of components	H <sub>2</sub>	6	max.	
Length of lacquer under the comp. bottom	H <sub>3</sub>	2	± 1	1 to 4 max. for 3.3 Ω to 220 Ω
Length of snapped lead	L	11.0	max.	
Pitch between thermistors	P	12.7	± 1.0	
Feed hole pitch	P <sub>0</sub>	12.7	± 0.3	Cumulative pitch error ± 1 mm/20 pitches
Feed hole center to lead center	P <sub>1</sub>	5.08	± 0.7	guaranteed between component and tape
Component alignment	Δp	0	± 1.3	
Total thickness	T	3.0	max.	4 max. for 3.3 Ω to 220 Ω
Total tape thickness	t	0.9	max.	with cardboard tape 0.5 ± 0.1
Tape width	W	18.0	± 1.0 - 0.5	None of the hold down tapes may cover the holes
Hold down tape width	W <sub>0</sub>	5.0	± 0.3	
Hole position	W <sub>1</sub>	9.0	± 0.5	
Hold down tape position	W <sub>2</sub>	1.5	± 1	



# NTCLE100E3...B0/T1/T2/2381 640 3/4/6....

NTC Thermistors, Radial Leaded,  
Standard Precision

Vishay BCcomponents

Thermistors on tape

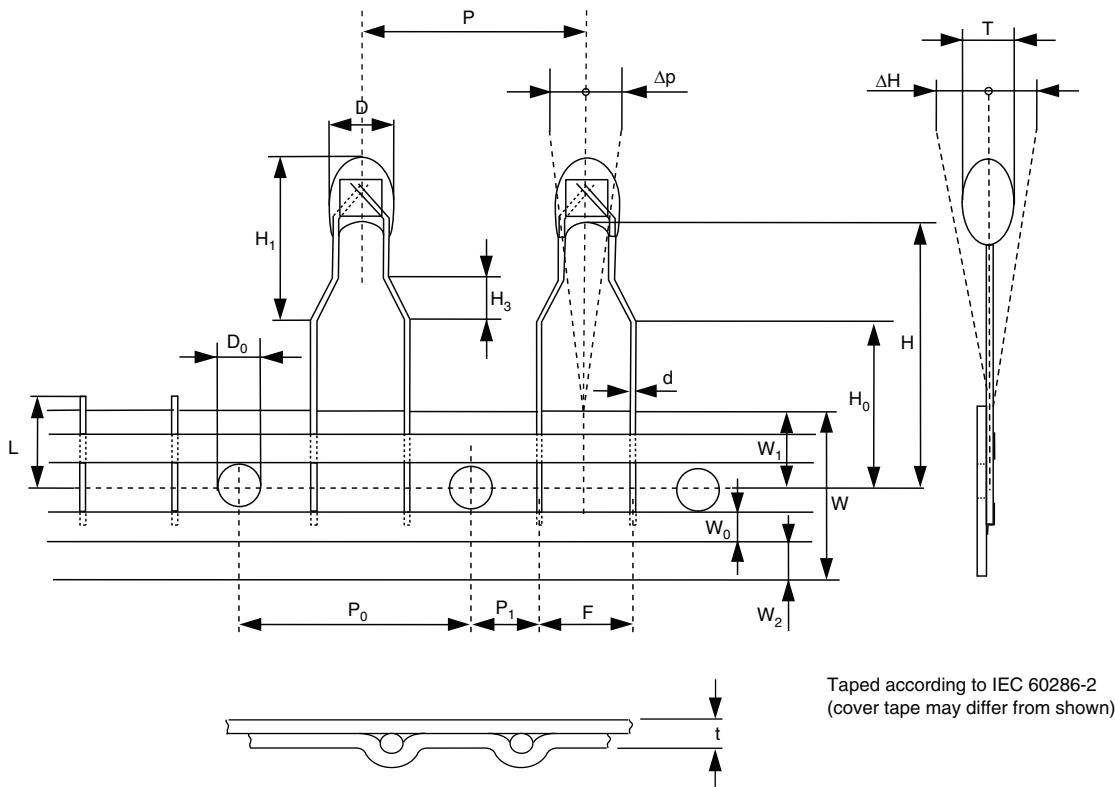

Taped according to IEC 60286-2  
(cover tape may differ from shown)

2E pitch

NTCLE100E3...T2/2381 640 3....

DIMENSIONS in millimeters				
DETAILS	SYMBOL	DIMENSIONS NOMINAL	TOLERANCE	REMARKS
Body diameter	D	3.3	± 0.5	5 max. for 3.3 Ω to 220 Ω
Lead diameter	d	0.6	± 10 %	
Feed hole diameter	D <sub>0</sub>	4.0	± 0.2	
Lead to lead distance	F	5.0	+ 0.6 - 0.1	Guaranteed between component and tape
Distance component to tape centre	H	20.0	± 2	12 max. for 100 Ω to 220 Ω
Component height	H <sub>0</sub>	16.0	± 0.5	
Component top to seating plane	H <sub>1</sub>	10.0	max.	
Component alignment	Δh	0.0	± 2.0	
Distance top - bottom lead clinch	H <sub>3</sub>			
Length of snapped lead	L	11.0	max.	
Pitch between thermistors	P	12.7	± 1.0	Cumulative pitch error ± 1 mm/20 pitches guaranteed between component and tape
Feed hole pitch	P <sub>0</sub>	12.7	± 0.3	
Feed hole center to lead center	P <sub>1</sub>	3.81	± 0.7	
Component alignment	Δp	0.0	± 1.3	
Total thickness	T	3.0	max.	4 max. for 3.3 Ω to 220 Ω with cardboard tape 0.5 ± 0.1
Total tape thickness	t	0.9	max.	
Tape width	W	18.0	± 1.0 - 0.5	None of the hold down tapes may cover the holes
Hold down tape width	W <sub>0</sub>	5.0	± 0.3	
Hole position	W <sub>1</sub>	9.0	± 0.5	
Hold down tape position	W <sub>2</sub>	1.5	± 1.0	

**REEL SPECIFICATIONS**

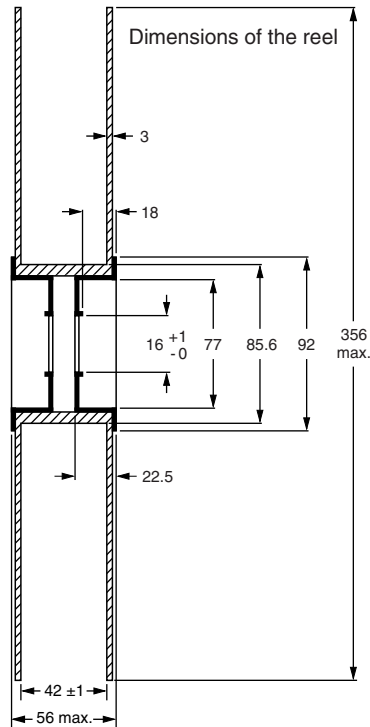

CODE NUMBERS AND RELEVANT PACKAGING QUANTITIES			
PARAMETER	BULK	TAPE AND REEL <sup>(1)</sup> 1E PITCH	TAPE AND REEL <sup>(1)</sup> 2E PITCH
	2381 640 6.../ NTCLE100E3...B0	2381 640 4.../ NTCLE100E3...T1	2381 640 3.../ NTCLE100E3...T2
Quantity	500	1500 per reel, 2 reels per box	1500 per reel, 2 reels per box

**Note**

<sup>(1)</sup> Taped according IEC 60286-2

**CHARACTERISTICS OF TAPED PRODUCTS**

- Minimum pull-out force of the component: 5 N
- Minimum peel-off force of adhesive tape: 6 N
- Minimum tearing force tape: 15 N
- Minimum pull-off force of tape-reel: 5 N

**STORAGE CONDITIONS**

- Storage temperature range: - 25 °C to + 40 °C
- Maximum relative humidity: 80 %, non-condensing

**TESTS AND REQUIREMENTS**

Essentially all tests are carried out in accordance with "IEC publication 60068-2; Environmental testing", except where indicated.

STABILITY TESTS				
CECC 32 100 CLAUSE	IEC 60068-2 TEST METHOD	TEST	PROCEDURE	REQUIREMENTS
D3; 4.20.1		Endurance	25 °C; 1000 h	$\Delta R/R < 1 \%$
	1	Endurance	- 40 °C; 1000 h	$\Delta R/R < 1 \%$
	539	Endurance	500 mW; 55 °C; 1000 h	$\Delta R/R < 3 \%$ <sup>(1)</sup>
	2	Dry heat, (steady state)	125 °C; 1000 h	$\Delta R/R < 3 \%$
D1; 4.19	3	Damp heat (steady state)	56 days at 40 °C; 90 to 95 % RH	$\Delta R/R < 3 \%$
C2; 4.14	14	Rapid change of temperature	- 40 °C to + 125 °C; 50 cycles	$\Delta R/R < 2 \%$
Other applicable tests				
	21	Robustness of leads: Tensile strength Bending	Loading force 10 N Loading force 5 N	$\Delta R/R \leq 1 \%$
	58	Soldering: Solderability Resistance to heat	240 °C max.; duration 4 s max. 265 °C max.; duration 5 s max.	$\Delta R/R \leq 1 \%$ <sup>(2)</sup>
	27	Impact	Free fall; 1 m	$\Delta R/R \leq 1 \%$
	29	Shock	490 m/s; half sinewave	$\Delta R/R \leq 1 \%$
	45	Resistance to solvent (isopropanol)	Ambient temp for 5 minutes; 5 N with hydrophylic cotton wool	No traces of lacquer on cotton wool
	6	Vibration	1.5 mm peak to peak: 10 Hz to 58 Hz 10 gp: 50 Hz to 500 Hz 1 octave/min. 2 h in each direction in three orthogonal directions	No visible damage $\Delta R/R < 1 \%$
	60695-2-2	Inflammability	1980, needle flame test	Non-flammable

**Notes**

- <sup>(1)</sup> For  $R_{25} \geq 100 \text{ k}\Omega$  the drift requirement is  $\Delta R/R < 5 \%$
- <sup>(2)</sup> For  $R_{25}$  from 2.2 k $\Omega$  to 10 k $\Omega$ , requirement is  $\pm 2 \%$  max.



## Disclaimer

ALL PRODUCT, PRODUCT SPECIFICATIONS AND DATA ARE SUBJECT TO CHANGE WITHOUT NOTICE TO IMPROVE RELIABILITY, FUNCTION OR DESIGN OR OTHERWISE.

Vishay Intertechnology, Inc., its affiliates, agents, and employees, and all persons acting on its or their behalf (collectively, "Vishay"), disclaim any and all liability for any errors, inaccuracies or incompleteness contained in any datasheet or in any other disclosure relating to any product.

Vishay makes no warranty, representation or guarantee regarding the suitability of the products for any particular purpose or the continuing production of any product. To the maximum extent permitted by applicable law, Vishay disclaims (i) any and all liability arising out of the application or use of any product, (ii) any and all liability, including without limitation special, consequential or incidental damages, and (iii) any and all implied warranties, including warranties of fitness for particular purpose, non-infringement and merchantability.

Statements regarding the suitability of products for certain types of applications are based on Vishay's knowledge of typical requirements that are often placed on Vishay products in generic applications. Such statements are not binding statements about the suitability of products for a particular application. It is the customer's responsibility to validate that a particular product with the properties described in the product specification is suitable for use in a particular application. Parameters provided in datasheets and/or specifications may vary in different applications and performance may vary over time. All operating parameters, including typical parameters, must be validated for each customer application by the customer's technical experts. Product specifications do not expand or otherwise modify Vishay's terms and conditions of purchase, including but not limited to the warranty expressed therein.

Except as expressly indicated in writing, Vishay products are not designed for use in medical, life-saving, or life-sustaining applications or for any other application in which the failure of the Vishay product could result in personal injury or death. Customers using or selling Vishay products not expressly indicated for use in such applications do so at their own risk and agree to fully indemnify and hold Vishay and its distributors harmless from and against any and all claims, liabilities, expenses and damages arising or resulting in connection with such use or sale, including attorneys fees, even if such claim alleges that Vishay or its distributor was negligent regarding the design or manufacture of the part. Please contact authorized Vishay personnel to obtain written terms and conditions regarding products designed for such applications.

No license, express or implied, by estoppel or otherwise, to any intellectual property rights is granted by this document or by any conduct of Vishay. Product names and markings noted herein may be trademarks of their respective owners.