

1. INTRODUCTION

The CERTI-CRIMP II Straight Action Hand Tools are designed to crimp a variety of loose piece terminals.



NOTE

Refer to the CERTI-CRIMP II Data Sheets at <http://tooling.te.com/data.asp> for a list of loose piece terminals that can be crimped with the CERTI-CRIMP II Straight Action Hand Tool. The website also contains instructions in various languages.



CAUTION

The wire crimper bottoms against the anvil before the CERTI-CRIMP ratchet control releases. This design feature ensures maximum electrical and tensile performance of the crimp. **Do not** re-adjust the ratchet.

简介

CERTI-CRIMP II 直动式手工工具用于压接多种散装端子。

注意：请登录 <http://tooling.te.com/data.asp> "Documentation" - "CERTI-CRIMP Data Sheets" 网站以获取可由 CERTI-CRIMP II 直动式手工工具压接的端子列表。

注意：在 CERTI-CRIMP 棘轮释放前，其压线刀下行至贴住底刀的位置。此设计用于确保压接后能得到最大的电气及拉力性能。棘轮位置不允许调整。

1. INTRODUCTION

Les pinces à action directe CERTI-CRIMP II permettent de sertir différents types de cosses en vrac.

REMARQUE

La liste complète des cosses en vrac sertissables à l'aide de la pince à action directe CERTI-CRIMP II est consultable sur le site <http://tooling.te.com/data.asp> "Documentation" - "CERTI-CRIMP Data Sheets" Ce site comporte également des instructions dans différentes langues.

ATTENTION

Le poinçon du fil vient en butée contre l'enclume avant le déblocage de la crémaillère CERTI-CRIMP. Cette fonctionnalité permet d'assurer des performances de sertissage optimales tant sur le plan électrique que sur celui de la tenue en traction du fil. NE PAS retoucher au réglage de la crémaillère.

1. はじめに

CERTI-CRIMP II ストレートアクション・ハンドツールは、様々なバラ状端子の圧着用に設計されています。

注記

それぞれの CERTI-CRIMP II ストレートアクション・ハンドツールで圧着できる端子のリストは、<http://tooling.te.com/data.asp> "Documentation" - "CERTI-CRIMP Data Sheets" でご覧になれます。また、このウェブサイトでは各国の言語に翻訳されているこの取扱説明書をご覧になれます。

注意

ツールのラチェットが解除される前に、ワイヤークリムパーがアンビルに突き当たります。この方式により、圧着の電気的および機械的性能を最大限に引き出します。お客様でのラチェットの再調整は、絶対にしないでください。

1. EINFÜHRUNG

Die CERTI-CRIMP II Handzange ist dazu vorgesehen, unterschiedliche Klemmen zu crimpen.

ANMERKUNG

Siehe <http://tooling.te.com/data.asp> "Documentation" - "CERTI-CRIMP Data Sheets" für eine Aufstellung von LP-Kontakte, die mit der CERTI-CRIMP Handzange gecrimpt werden können. Die Website enthält auch Anleitungen in verschiedenen Sprachen.

VORSICHT

Das Werkzeugoberteil fährt immer auf Block mit den Amboß, bevor die CERTI-CRIMP Handzange die Ratsche freigibt. Dies ist ein Konstruktionsmerkmal, welches maximale Verpressung und Zugfestigkeit des Crimp-Kontaktes gewährleistet. Die Ratsche darf nicht verstellt werden.

1. INTRODUZIONE

Gli attrezzi manuali CERTI-CRIMP II Straight Action sono progettati per aggirare vari tipi di terminali sciolti.

NOTA

Per la lista dei terminali sciolti che possono essere aggirati con l'attrezzo manuale CERTI-CRIMP II Straight Action, consultare il sito multilingua <http://tooling.te.com/data.asp> "Documentation" - "CERTI-CRIMP Data Sheets".

ATTENZIONE

Prima del rilascio del cricchetto, la matrice di aggiratura è appoggiata sull'incudine. Tale condizione garantisce prestazioni ottimali dell'aggiratura in termini di elettricità e tensione. NON modificare la regolazione del cricchetto.

PROPER USE GUIDELINES

Cumulative trauma disorders can result from the prolonged use of manually powered hand tools. Hand tools are intended for occasional use and low-volume applications. A wide selection of powered application equipment is available for extended-use production operations.

Figure 1: CERTI-CRIMP Straight Action Hand Tool 2305680-1 with Interchangeable Flip Locator 2361710-1

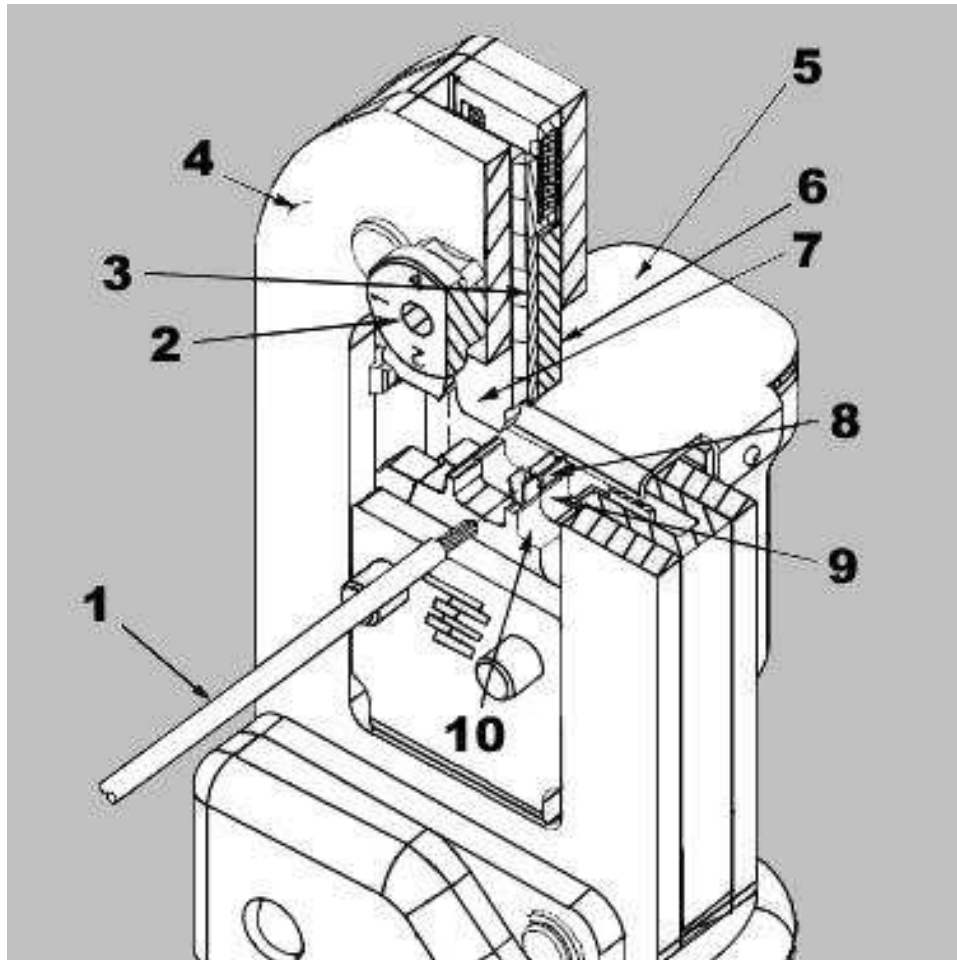

- | | |
|---|------------------------------|
| 1 Stripped wire | 6 Wire crimper |
| 2 Insulation adjustment knob (shown in position 4) | 7 Insulation crimper |
| 3 Insulation stop | 8 Contact wire barrel |
| 4 Front of tool | 9 Wire anvil |
| 5 Contact retaining plate | 10 Insulation anvil |

2. DESCRIPTION

The front of the tool is marked with the tool part number, wire size ranges, and crimp height specification. The tool includes the following features:

- Fixed die (crimper)
- Movable die (anvil)
- Insulation stop
- CERTI-CRIMP hand crimping tool ratchet control
- Flip locator

Many tools feature an insulation adjustment knob, which is used to regulate the crimp height of the contact insulation barrel during the crimping operation. The flip locator is a feature used to locate the contact in the crimp tooling. The insulation stop limits the insertion distance of the stripped wire into the contact. In use, the insulation stop rests in the slot of the contact (see Figure 1 and Figure 2). The ratchet control ensures full crimping of the contact. When engaged, the ratchet does not release until the dies have been fully closed.

Figure 2: Typical socket and pin contacts (not to scale)

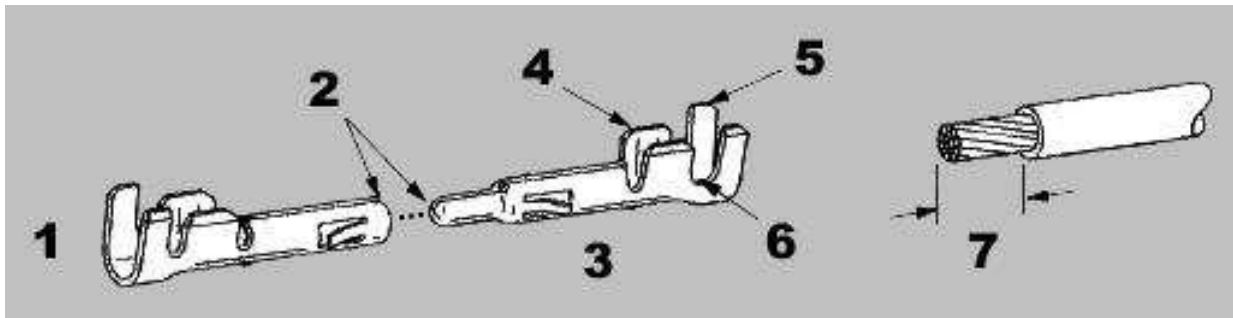

- | | |
|---------------------------------|----------------------------|
| 1 Typical socket contact | 5 Insulation barrel |
| 2 Mating portion | 6 Locator slot |
| 3 Typical pin contact | 7 Wire strip length |
| 4 Wire barrel | |

3. INTERCHANGE PROCEDURE

1. Refer to the terminal Application Specification to verify that the flip locator you intend to use is compatible with the tool.
2. Remove the RTV sealant from the pivot hole of the flip locator currently installed on the tool (Figure 3).

Figure 3: Removing RTV sealant



3. Push the dowel pin out of the pivot hole of the flip locator (Figure 4).

Figure 4: Removing dowel pin



4. Install the appropriate flip locator for the tool and terminal combination.
5. Push the dowel pin into the pivot hole of the flip locator until it bottoms.
6. Re-install RTV sealant in the flip locator pivot hole to retain the dowel pin.

4. MAINTENANCE AND INSPECTION

Maintain and inspect the tool periodically to ensure dependable and uniform terminations. Frequency of inspection depends on:

- Care, amount of use, and handling of the tool
- Amount of dust and dirt
- Degree of operator skill
- Your established standards

4.1. Inspection

The hand tool is inspected before it is shipped. Inspect it immediately when it arrives at your facility to ensure that the tool has not been damaged during shipment.

4.2. Daily maintenance

- Remove dust, moisture, and other contaminants with a clean brush or a soft, lint-free cloth. Do **not** use objects that could damage the tool.
- Make certain that the retaining pins are in place and secured with retaining rings (Figure 5).
- Protect all pins, pivot points, and bearing surfaces with a thin coat of any good SAE 20 oil. Do not oil excessively.
- When the tool is not in use, keep the handles closed to prevent objects from becoming lodged in the crimping jaws.
- Store the tool in a clean, dry area.

Figure 5: Retaining pins and rings (closed to last ratchet point before release)

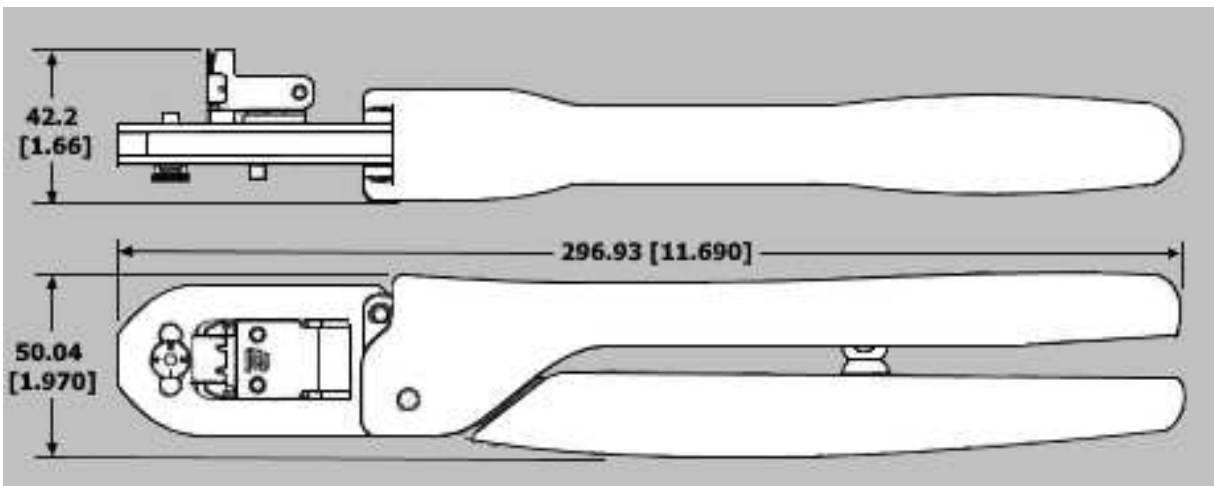

5. REPLACEMENT AND REPAIR

Replacement parts are listed in Table 1. Parts other than those listed in Table 1 should be replaced by TE to ensure quality and reliability of the tool.

Table 1: Replaceable parts

Part number	21045-3
Description	Retaining ring
Quantity per tool	4

To obtain replacement parts, refer to the appropriate instruction sheet or customer manual and order parts through your TE representative. You can also order parts by any of the following methods:

- Go to TE.com and click the **Shop TE** link at the top of the page.
- Call 800-522-6752.
- Write to:

CUSTOMER SERVICE (038-035)
TE CONNECTIVITY CORPORATION
PO BOX 3608
HARRISBURG PA 17105-3608

Tools can also be returned for evaluation and repair. For tool repair services, call 800-522-6752.

6. REVISION SUMMARY

Initial release