

**Major Ratings and Characteristics**

Characteristics	1N6660CCT1	Units
$I_{F(AV)}$	30	A
$V_{RRM}$ (Per Leg)	45	V
$I_{FSM}$ @ $t_p = 8.3ms$ half-sine (Per Leg)	300	A
$V_F$ @ 20Apk, $T_J = 125^\circ C$ (Per Leg)	0.70	V
$T_J, T_{stg}$ Operating and storage	-65 to 150	$^\circ C$

**Description/Features**

The 1N6660CCT1 center tap Schottky rectifier has been expressly designed to meet the rigorous requirements of high reliability environments. It is packaged in the hermetic isolated TO-254AA package. The device's forward voltage drop and reverse leakage current are optimized for the lowest power loss and the highest circuit efficiency for typical high frequency switching power supplies and resonant power converters. Full MIL-PRF-19500 quality conformance testing is available on source controlled drawings to TX, TXV and S levels.

- Hermetically Sealed
- Center Tap
- High Frequency Operation
- Guard Ring for Enhanced Ruggedness and Long Term Reliability
- Electrically Isolated
- ESD Rating: Class 3A per MIL-STD-750, Method 1020

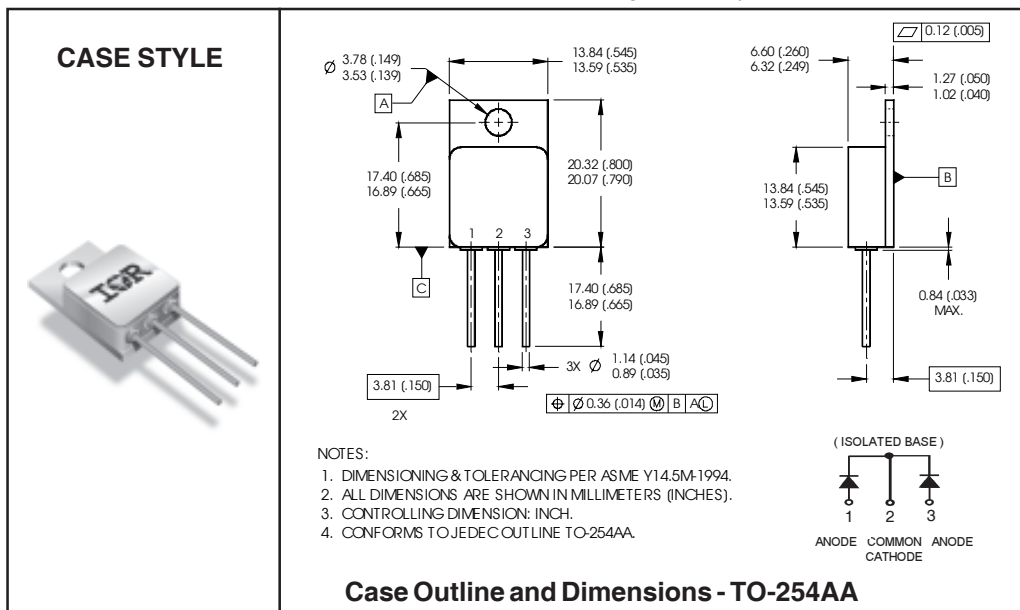

**Voltage Ratings**

Part number	1N6660CCT1
V <sub>R</sub> Max. DC Reverse Voltage (V) (Per Leg)	45
V <sub>RWM</sub> Max. Working Peak Reverse Voltage (V) (Per Leg)	

**Absolute Maximum Ratings**

Parameters	Limits	Units	Conditions
I <sub>F(AV)</sub> Max. Average Forward Current See Fig. 5	30	A	50% duty cycle @ T <sub>C</sub> = 118°C, rectangular waveform
I <sub>FSM</sub> Max. Peak One Cycle Non - Repetitive Surge Current (Per Leg)	300	A	@ t <sub>p</sub> = 8.3 ms half-sine

**Electrical Specifications**

Parameters	Limits	Units	Conditions	
V <sub>FM</sub> Max. Forward Voltage Drop (Per Leg) ①	0.80	V	@ 15A	T <sub>J</sub> = -55°C
	0.55	V	@ 5.0A	T <sub>J</sub> = 25°C See Fig. 1
	0.75	V	@ 15A	
	1.0	V	@ 30A	
I <sub>RM</sub> Max. Reverse Leakage Current (Per Leg) See Fig. 2 ①	1.0	mA	T <sub>J</sub> = 25°C	V <sub>R</sub> = rated V <sub>R</sub>
	40	mA	T <sub>J</sub> = 125°C	
C <sub>T</sub> Max. Junction Capacitance (Per Leg)	2000	pF	V <sub>R</sub> = 5V <sub>DC</sub> ( 1MHz, 25°C )	
L <sub>S</sub> Typical Series Inductance (Per Leg)	6.7	nH	Measured from anode lead to cathode lead 6mm ( 0.025 in.) from package	

**Thermal-Mechanical Specifications**

Parameters	Limits	Units	Conditions
T <sub>J</sub> Max. Junction Temperature Range	-65 to 125	°C	
T <sub>stg</sub> Max. Storage Temperature Range	-65 to 150	°C	
R <sub>thJC</sub> Max. Thermal Resistance, Junction to Case (Per Leg)	1.65	°C/W	DC operation See Fig. 4
R <sub>thJC</sub> Max. Thermal Resistance, Junction to Case (Per Package)	0.85	°C/W	DC operation
wt Weight (Typical)	9.3	g	
Die Size	150X150	mils	
Case Style	TO-254AA		

① Pulse Width &lt; 300μs, Duty Cycle &lt; 2%

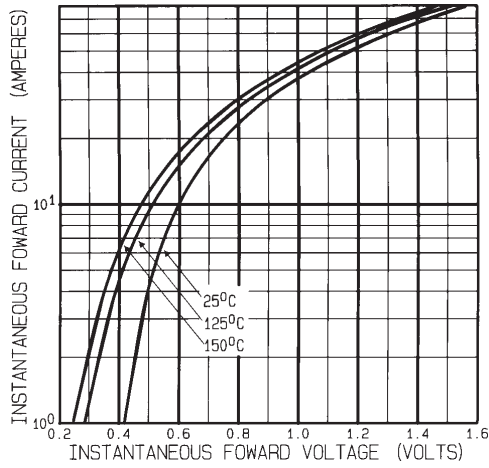

Fig. 1 - Max. Forward Voltage Drop Characteristics (Per Leg)

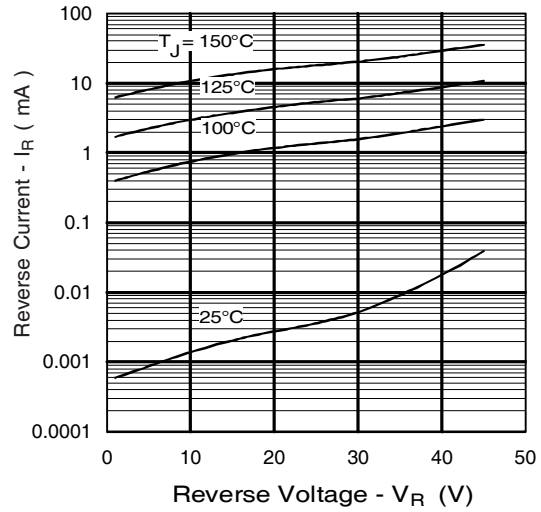

Fig. 2 - Typical Values of Reverse Current Vs. Reverse Voltage (Per Leg)

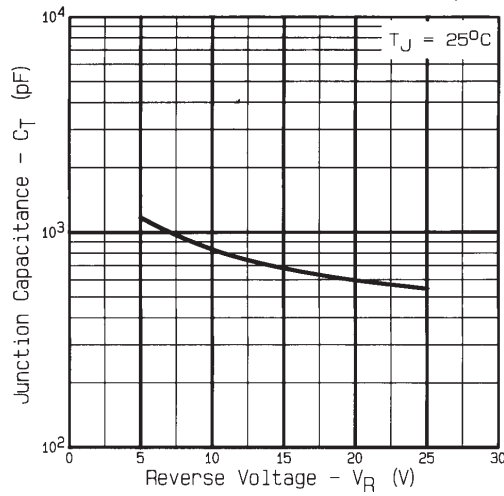

Fig. 3 - Typical Junction Capacitance Vs. Reverse Voltage (Per Leg)

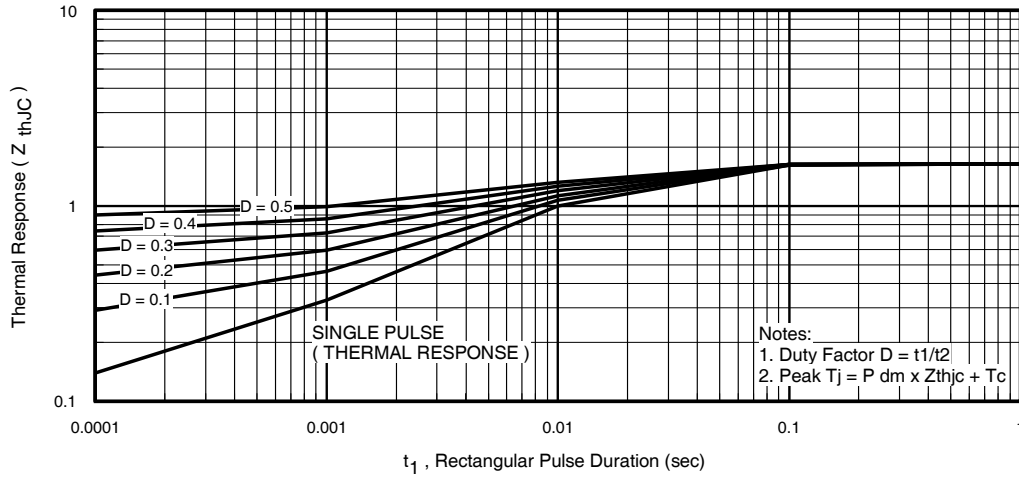

Fig. 4 - Max. Thermal Impedance  $Z_{thJC}$  Characteristics (Per Leg)

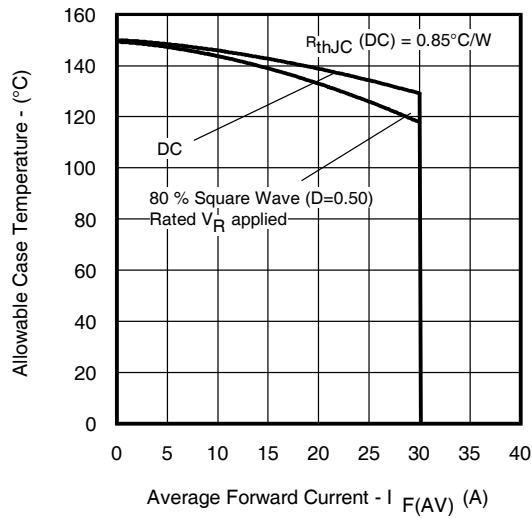

Fig. 5 - Max. Allowable Case Temperature Vs. Average Forward Current (Per Package)