

SERIES 22:



ACTUAL SIZE



MINIATURE 10 AMP DOUBLE-POLE/SIMULTANEOUS SNAP ACTION SWITCHES

This rugged double-pole double-break Butterfly® mechanism switch can be configured for Form XX, Form YY or Form ZZ switching. This unique design is ideal for your toughest applications where reliability is a must.

KEY FEATURES:

- Gold or silver contacts
- Variety of terminal styles
- UL recognized and CSA certified
- Roller lever and overtravel plunger actuator are available

APPLICATIONS

- Pressure control sensors
- Pendant controls
- Door openers for transit equipment
- Valve actuator
- Lift trucks
- Interlock kiosk

ORDERING INFORMATION:

Switches

Part Number	Terminals
22-104	End Solder
22-204	#4 Screw
22-304	Side Solder
22-504	Quick Disconnect .250

actuator (see page 69 for additional specifications)

Part Number	Oper. Force	Release Force	Pretravel	Overtravel	Movement Diff.	Operating Point
72-1160 Roller Lever (1)	10 oz max	1.5 oz min	.150 max	.035 min	.070 ± .015	1.0 ± .031
72-2080 Over Travel (2)	17 ± 5 oz	4 oz min	.060 max	.215 min	.030 ± .007	.828±.031

(1) When used with 22-104 basic switch or 22-204 basic switch
 (2) When used with 22-304 basic switch

STANDARDS / AGENCY / RATINGS:



END SOLDER

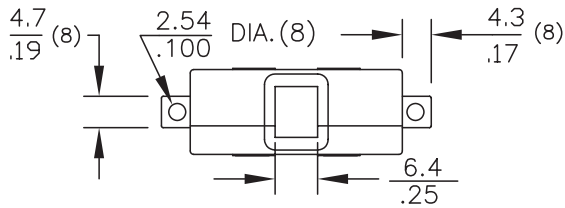

#4 SCREW

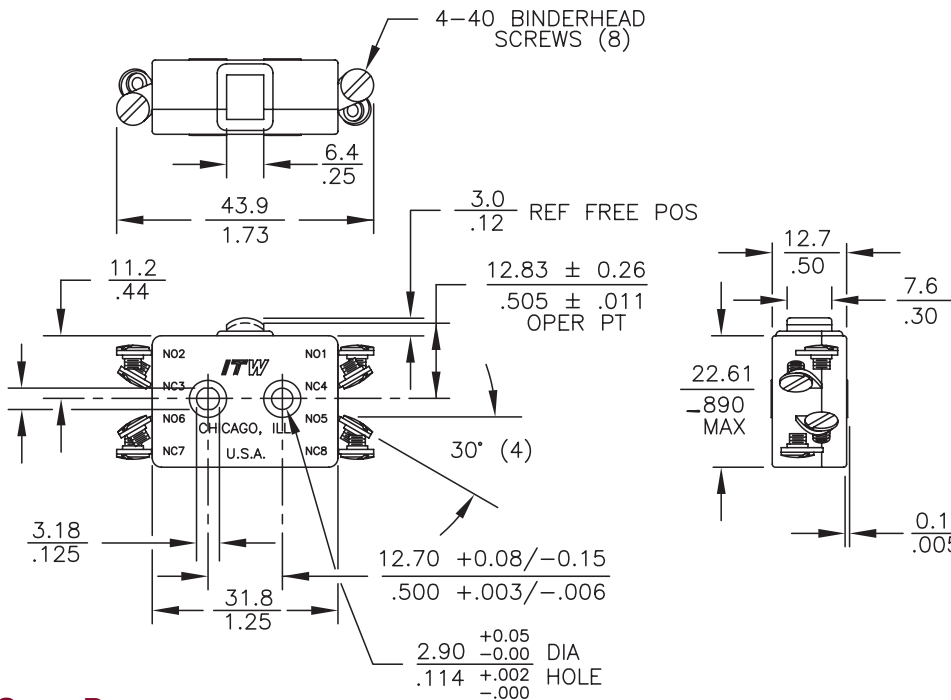

QUICK DISCONNECT

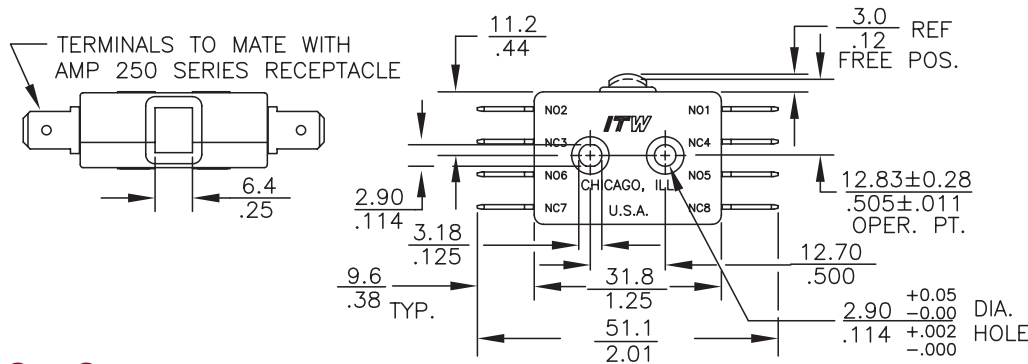

SIDE SOLDER

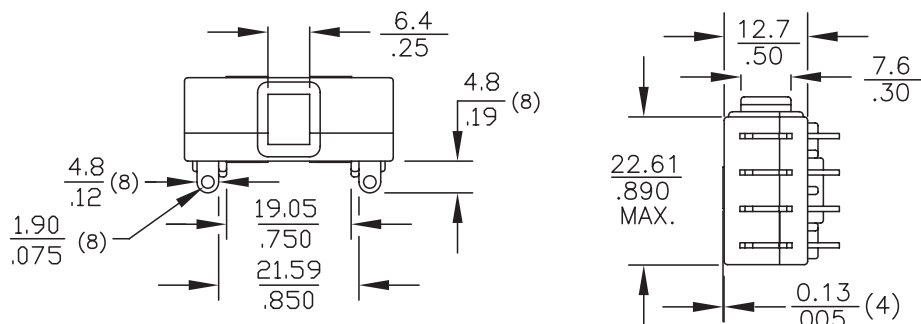

MECHANICAL / ELECTRICAL CHARACTERISTICS:

- Pretravel:** 0.060 inches max
- Overtravel:** 0.015 inches min
- Operating Force:** 17 ± 5 oz
- Release Force:** 4 oz min
- Movement Differential:** 0.030 inches ± .009
- Operating Point:** 0.505 inches ± .011 (from mounting hole centers)

Circuit: DPDT-DB (Form ZZ)

Electrical Ratings:

Circuitry	125/250 VAC	28 VDC
DPST-DB NO or NC (Form XX or YY)	10 amp (75-80% PF) 1/2 HP 125 VAC	10 amp Ind 15 amp Res
DPDT-DB (Form ZZ)	3/4 HP 250 VAC	7 amp Ind 10 amp Res

SERIES 22:

KEY FEATURES:

- Roller Lever
- Overtravel

MECHANICAL CHARACTERISTICS:

Part Number	Oper. Force	Release Force	Pretravel	Overtravel	Movement Diff.	Operating Point
72-1160 Roller Lever (1)	10 oz max	1.5 oz min	.150 max	.035 min	.070 ± .015	1.0 ± .031
72-2080 over travel (2)	17 ± 5 oz	4 oz min	.060 max	.215 min	.030 ± .007	.828 ± .031

(1) When used with 22-104 basic switch or 22-204 basic switch. (2) When used with 22-304 basic switch

72-1160

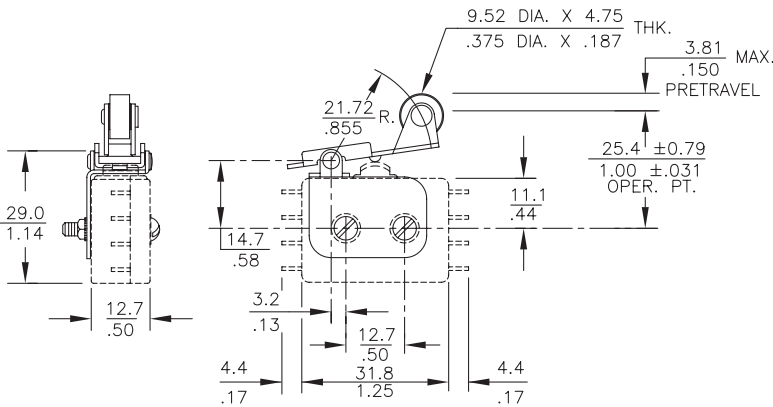

72-2080

