

THIS DRAWING IS A CONTROLLED DOCUMENT

NUMBER
2079383

PART NUMBER	REV	MASS REF Grams or Pounds	THREAD	A	B	C	D	E
2079383-1	A	0.65	M3	8.0	5.7	1.65	2.0	1.04
2079383-2	B	0.76	M3	10.0	5.7	1.65	2.0	1.04
2079383-3	C	4.43	M4	40.0	7.6	2.20	2.5	1.30
2079383-4	D	1.27	M4	8.0	7.6	2.20	2.5	1.30
2079383-5	D	2.46	M4	20.0	7.6	2.20	2.5	1.30
2079383-6	D	8.06	M8	12.0	14.0	4.40	5.0	2.60
2079383-7	D	13.19	M8	25.0	14.0	4.40	5.0	2.60
2079383-8	D	2.06	M4	16.0	7.6	2.20	2.5	1.30
2079383-9	D	5.86	M6	20.0	10.5	3.30	4.0	2.08
1-2079383-0	D	0.54	M3	6.0	5.7	1.65	2.0	1.04
1-2079383-1	E	4.08	M6	12.0	10.5	3.30	4.0	2.08
1-2079383-2	F	1.67	M4	12.0	7.6	2.20	2.5	1.30
1-2079383-3	G	2.95	M4	25.0	7.6	2.20	2.5	1.30
1-2079383-4	G	3.44	M4	30.0	7.6	2.20	2.5	1.30
1-2079383-5	H	19.10	M8	40.0	14.0	4.40	5.0	2.60
1-2079383-6	J	1.47	M4	10.0	7.6	2.20	2.5	1.30
1-2079383-7	K	2.80	M5	12.0	9.5	2.75	3.0	1.56
1-2079383-8	L	1.07	M4	6.0	7.6	2.20	2.5	1.30
1-2079383-9	M	15.16	M8	30.0	14.0	4.40	5.0	2.60
2-2079383-0	M	17.13	M8	35.0	14.0	4.40	5.0	2.60

1. MANUFACTURER/VENDOR PART NUMBER:
NONE
2. MANUFACTURER/VENDOR:
NONE
3. DIMENSIONS/TOLERANCES:
DIMENSIONS SHALL COMPLY WITH ASME B18.3.4M AND ISO 7380.
ALL DIMENSIONS SHOWN ARE NOMINAL UNLESS OTHERWISE SPECIFIED.
4. COMPLIANCE:
ALL MATERIALS, COMPONENTS AND PROCESSES SHALL COMPLY WITH TEC-138-702 (CONTAINS NO BANNED SUBSTANCES).
5. REQUIRED CHARACTERISTICS/PERFORMANCE:
MATERIAL SHALL BE STEEL THAT MEETS OR EXCEEDS ISO STANDARD 898/1, CLASS 10.9
FINISH IS ZINC W/CLEAR CHROMATE (III)
SEE TABLE FOR ADDITIONAL INFORMATION
6. ALTERNATE PART NUMBER AND MANUFACTURER/VENDOR:
TE ENGINEERING APPROVED EQUIVALENT.

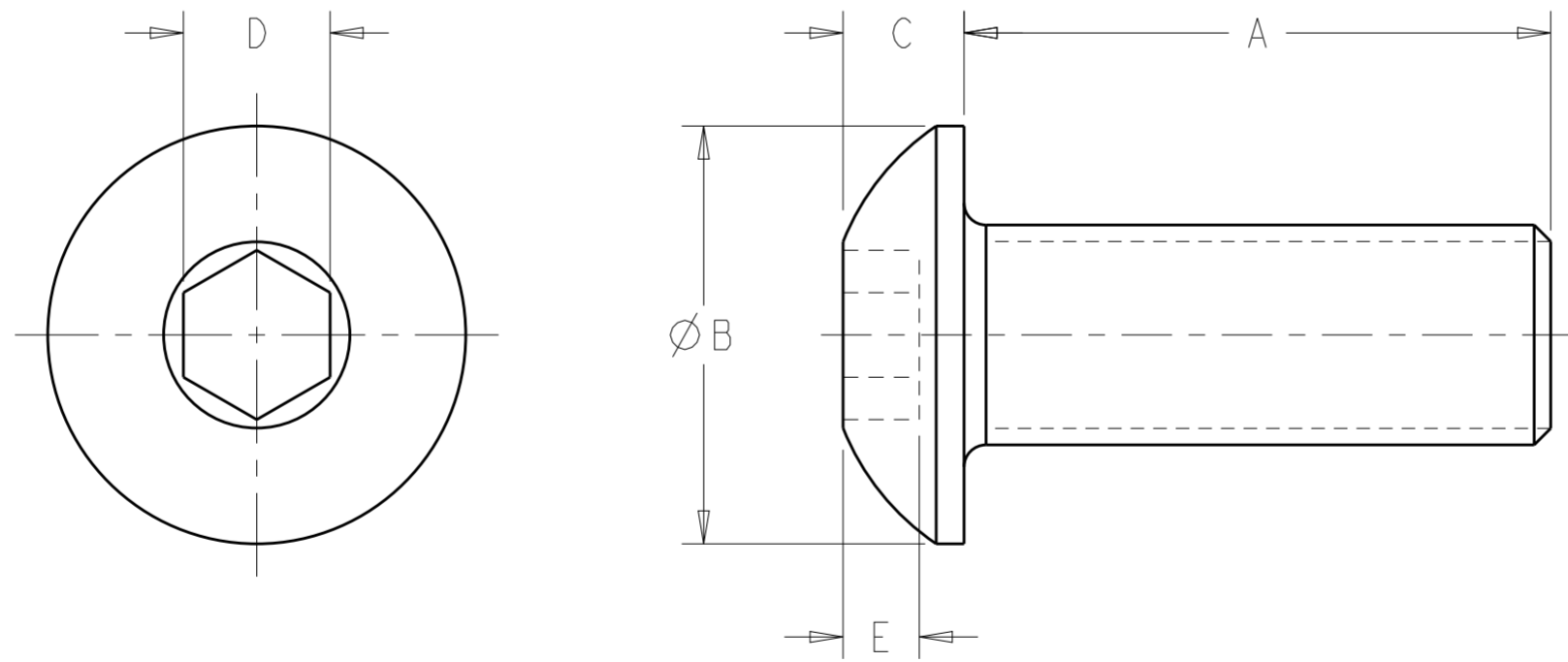

THIS INFORMATION IS CONFIDENTIAL AND PROPRIETARY TO TYCO ELECTRONICS CORPORATION AND ITS WORLDWIDE SUBSIDIARIES AND AFFILIATES (TE). IT MAY NOT BE DISCLOSED TO ANYONE, OTHER THAN TE PERSONNEL, WITHOUT AUTHORIZATION FROM TE (www.te.com).

APPLICATION TOOLING COMMERCIALY PURCHASED PRODUCT SPECIFICATION

DIMENSIONS: mm	MATERIAL SEE NOTES	FINISH SEE NOTES
TITLE SCREW, CAP, BUTTON SOCKET HEAD, METRIC, RoHS COMPLIANT		
SIZE A2	NUMBER 2079383	SHEET 1 OF 1
M	ADD -19 AND -20 / ECR-18-014191	DATE 06AUG2018
LTR	REVISION RECORD	DATE DWN APVD